

# WEM PROCEDURE: FACILITY SUB-METERING

PREPARED BY: AEMO  
DOCUMENT REF:  
VERSION: 1.1  
EFFECTIVE DATE:  
STATUS: DRAFT

Approved for distribution and use by:

APPROVED BY: DRAFT – NOT APPROVED FOR USE  
TITLE:

DATE: XX/XX/2021

## VERSION RELEASE HISTORY

Version	Effective Date	Summary of Changes
1.0	01 July 2021	New WEM Procedure
1.1	01 December 2021	Revised for DC Metering and SCADA

### IMPORTANT NOTICE - EXPLANATORY NOTES

#### Disclaimer

Explanatory notes included in this document as shaded in-line text are provided for explanatory purposes only to assist with comprehension and readability. The information contained in these explanatory notes does not constitute legal or business advice and should not be relied on as a substitute for obtaining detailed advice about the *Electricity Industry Act 2004 (WA)*, the WEM Rules, or any other applicable laws, procedures or policies. AEMO has made reasonable efforts to ensure the quality of the information, but cannot guarantee its accuracy or completeness.

Accordingly, to the maximum extent permitted by law, AEMO and its officers, employees and consultants involved in the preparation of this document:

- make no representation or warranty, express or implied, as to the currency, accuracy, reliability or completeness of the explanatory information in this document; and
- are not liable (whether by reason of negligence or otherwise) for any statements or representations in this document, or any omissions from it, or for any use or reliance on the information in it.

#### Copyright

© 2021 Australian Energy Market Operator Limited. The material in this publication may be used in accordance with the copyright permissions on AEMO's website.

## CONTENTS

1.	INTRODUCTION	4
1.1.	Purpose and scope	4
1.2.	Definitions	4
1.3.	Interpretation	5
1.4.	Related documents	5
2.	FACILITY SUB-METERING REQUIREMENTS	6
2.2.	Alternating Current Metering	6
2.3.	SCADA	7
3.	THE COMMUNICATION REQUIREMENTS AND PROTOCOLS BETWEEN A MARKET PARTICIPANT AND AEMO	10
4.	AUDITING OF FACILITY SUB-METERING	12
4.1.	Initial Audit of Facility Sub-Metering	12
4.2.	Subsequent auditing of Facility Sub-Metering	13
4.3.	Market Participant identification of outages or malfunctions	14
4.4.	Rectification of Facility Sub-Metering	14
APPENDIX A.	RELEVANT CLAUSES OF THE WEM RULES	<b>16</b>

**TABLES**

Table 1	Definitions .....	4
Table 2	Related documents .....	5
Table 3	Relevant clauses of the WEM Rules .....	16

## 1. INTRODUCTION

### 1.1. Purpose and scope

- 1.1.1. This WEM Procedure: Facility Sub-Metering (Procedure) is made in accordance with AEMO's functions under clause 2.1A.2(h) of the Wholesale Electricity Market Rules (WEM Rules).
- 1.1.2. The Electricity Industry Act 2004, the WEM Regulations and the WEM Rules prevail over this Procedure to the extent of any inconsistency.
- 1.1.3. In this Procedure, where obligations are conferred on a Rule Participant, that Rule Participant must comply with the relevant obligations in accordance with clause 2.9.7A or 2.9.8 of the WEM Rules, as applicable.
- 1.1.4. The purpose of this Procedure is to outline:
- the characteristics and requirements of Facility Sub-Metering, including accuracy requirements;
  - the procedures to be followed by Market Participants for auditing of Facility Sub-Metering;
  - the communication requirements and protocols between a relevant Market Participant and AEMO;
  - the processes to be followed by a Market Participant for providing Facility Sub-Metering information to AEMO; and
  - any other matters which AEMO considers relevant.
- 1.1.5. Appendix A of this Procedure outlines the head of power clauses that this Procedure is made under, as well as other obligations in the WEM Rules covered by this Procedure.

### 1.2. Definitions

- 1.2.1. Terms defined in the Electricity Industry Act 2004, the WEM Regulations and the WEM Rules have the same meanings in this Procedure unless the context requires otherwise.
- 1.2.2. The following definitions apply in this Procedure unless the context requires otherwise.

**Table 1 Definitions**

Term	Meaning
Data Communication Providers (DCPs)	Has the meaning given under WEM Procedure: Communications and Control Systems.
Dispatch Data	Has the meaning given under WEM Procedure: Communications and Control Systems.
Interval Energy Data	The data that results from the measurement of the flow of electricity in a power conductor where the data is prepared and recorded by the metering installation in intervals which correspond to a Trading Interval or are submultiples of a Trading Interval.
Planned Facility Upgrade	Where a Market Participant seeks a higher level of Certified Reserve Capacity than its existing Facility has demonstrated through normal market operation or a Reserve Capacity Test, due to works yet to be completed (known as an upgrade in WEMS).

Term	Meaning
Wholesale Electricity Market System or WEMS	An interface software that AEMO uses to administer and operate the Wholesale Electricity Market.

### 1.3. Interpretation

- 1.3.1. The following principles of interpretation apply in this Procedure unless the context requires otherwise.
- Clauses 1.3 to 1.5 of the WEM Rules apply in this Procedure.
  - References to time are references to Australian Western Standard Time.
  - Terms that are capitalised, but not defined in this Procedure, have the meaning given in the WEM Rules.
  - A reference to the WEM Rules or WEM Procedures includes any associated forms required or contemplated by the WEM Rules or WEM Procedures.
  - Words expressed in the singular include the plural and vice versa.
  - A reference to a paragraph refers to a paragraph of this Procedure.
  - A reference to a clause refers to a clause or section of the WEM Rules.
  - References to WEM Rules in this Procedure in bold and square brackets [Clause XXX] are included for convenience only, and do not form part of this Procedure.
  - Text located in boxes and headed as Explanatory Note X in this Procedure is included by way of explanation only and does not form part of this Procedure. The Procedure prevails to the extent of any inconsistency with the explanatory notes contained within it.
  - The body of this Procedure prevails to the extent of any inconsistency with the figures, diagrams, appendices, schedules, annexures or attachments contained within this document.

### 1.4. Related documents

- 1.4.1. The documents in Table 2 are associated with this Procedure.

**Table 2 Related documents**

Reference	Title	Location
WEM Rules	WEM Rules	<a href="#">Energy Policy WA Website</a>
Metering Code	The Electricity Industry (Metering) Code 2012	<a href="#">State Law Publisher</a>
WEM Procedure	WEM Procedure: Certification of Reserve Capacity	<a href="#">WEM Website</a>
WEM Procedure	WEM Procedure: Reserve Capacity Testing	<a href="#">WEM Website</a>
WEM Procedure	Power System Operation Procedure: Commissioning Tests	<a href="#">WEM Website</a>

Reference	Title	Location
WEM Procedure	WEM Procedure: Communications and Control Systems	<a href="#">WEM Website</a>

## 2. FACILITY SUB-METERING REQUIREMENTS

- 2.1.1. Facility Sub-Metering must be installed in a configuration sufficient, in combination with Meter Data Submissions, to calculate the contribution of each:
- Separately Certified Component (including any Parasitic Load associated with a Separately Certified Component); and
  - Energy Producing System, which is not a Separately Certified Component, to a Facility's Injection or Withdrawal.
- 2.1.2. A Market Participant may meet the requirements of paragraph 2.1.1 by either:
- metering each Separately Certified Component inclusive of all Parasitic Loads; or
  - metering one or more Separately Certified Components which, in combination with Meter Data Submissions, allows the contribution of each Separately Certified Component to be calculated,
- where:
- the energy consumption of any Parasitic Loads is associated with a Separately Certified Component; and
  - the energy production of any Energy Producing System that is not a Separately Certified Component is not associated with a Separately Certified Component.
- 2.1.3. A Market Participant must provide a formula to be used to calculate the contribution of each Separately Certified Component and each Energy Producing System which is not a Separately Certified Component, which meets the requirements of paragraph 2.1.1.
- 2.1.4. The sum of associated Interval Energy Data for each Separately Certified Component and any Energy Producing System which is not a Separately Certified Component, using the methodology determined under paragraph 2.1.3 must be equal to the total metered energy of the Facility Meter Data Submissions.
- 2.1.5. Sources of Facility Sub-Metering Interval Energy Data, for the purposes of paragraph 2.1.1 must meet the requirements of either paragraphs 2.2 or Error! Reference source not found..

## 2.2. Alternating Current Metering

- 2.2.1. An alternating current meter installed to meet the requirements of Facility Sub-Metering must be in accordance with the following requirements of the Metering Code:
- Division 3.5(2);
  - Division 3.8;

- (c) Division 3.9(1), (3), (6), (7), (8), (9) and (10), including Appendix 1 as applicable;
  - (d) Division 3.11A(1);
  - (e) Division 3.12; and
  - (f) Division 3.13.
- 2.2.2. For the purposes of paragraph 2.1.5, requirements of the Metering Code which are expressed to apply to a Network Operator are deemed to apply to Market Participants who are required to comply with this Procedure.
- 2.2.3. Meters installed for the purposes of Facility Sub-Metering must be capable of storing the following Interval Energy Data for 35 days at 5-minute intervals for each metering channel required as an input into the methodology required under paragraph Error! Reference source not found., including:
- (a) import active energy;
  - (b) export active energy;
  - (c) import reactive energy; and
  - (d) export reactive energy.
- 2.2.4. Meters installed for the purposes of Facility Sub-Metering must be configured to record and provide Interval Energy Data for each Trading Interval.
- 2.2.5. A Market Participant must store Facility Sub-Metering Interval Energy Data (in a format accessible within a reasonable period of time) for a period of time sufficient for the purposes of calculating the Relevant Level Methodology in accordance with Appendix 9 of the WEM Rules.

### **2.3. SCADA**

- 2.3.1. Facility Sub-Metering may use Interval Energy Data recorded by other devices where the collected Interval Energy Data has a maximum overall error at full load of less than  $\pm 1\%$ .

## E[A] Explanatory Note - Metering arrangements

### E[A1] Approach to capturing energy flows

A Facility Sub-Metering arrangement may achieve compliance with paragraph 2.1.1 using different configurations of metering. This explanatory note provides some examples of acceptable arrangements using different configurations of meters, including the use of Meter Data Submissions for the relevant Facility connection point.

Figure E[1] provides a simplified line diagram for a hybrid solar photovoltaic and battery energy storage system. The arrangement shown on the left of the figure includes metering at both Separately Certified Components ( $M_S$  and  $M_B$ ), where meter  $M_S$  captures all generation from the solar photovoltaic component of the Facility and the meter  $M_B$  captures all import and export from the battery energy storage system. The arrangement on the right of the figure uses a single meter  $M_B$  to capture import and export from the battery energy storage system, meaning the generation from the solar photovoltaic component can be calculated by subtracting the energy associated with meter  $M_B$  from the Meter Data Submission for the Facility ( $M_{NMI}$ ).

**Figure E[1] Example metering arrangements**

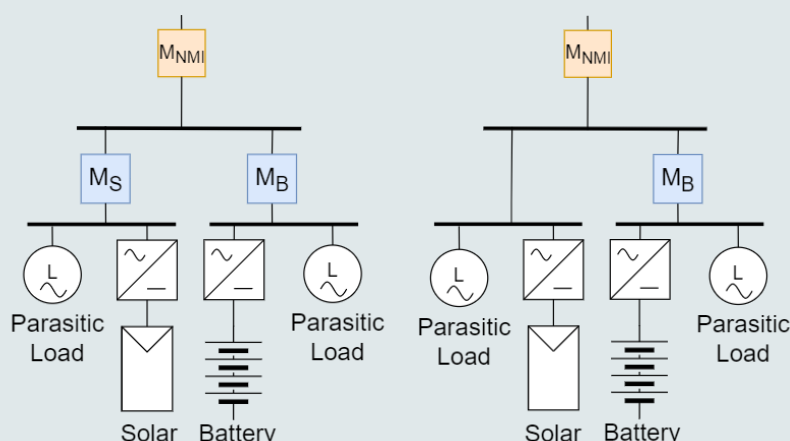

### E[A2] Approach to Parasitic Loads

Parasitic loads associated with each Separately Certified Component do not necessarily need to be separately metered for the purposes of Facility Sub-Metering. Options for the calculation and apportioning of auxiliary loads to meet the requirements of paragraph 2.1.2 may include allocating the metered energy of Parasitic Loads in proportion to the absolute value of metered energy from each Separately Certified Component. Figure E[2] shows an example where Parasitic Loads for the entire Facility are metered by  $M_L$ . In this example, the Parasitic Loads ( $M_L$ ) may be allocated according to the absolute values of the calculated contribution of the solar component and the battery component (metered by  $M_B$ ).



**Figure E[2] Example metering arrangements for shared parasitic loads**

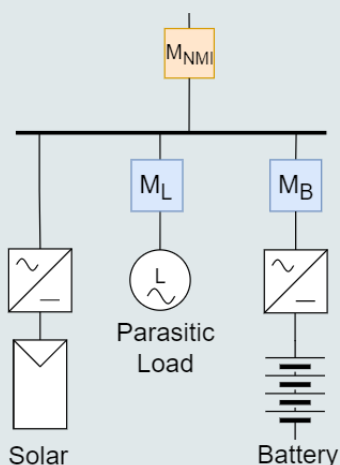

**E[A3] Approach to internal Facility losses**

The calculation of electrical losses due to internal Facility reticulation may be calculated using several approaches depending on the Facility Sub-Metering arrangement. Where the Facility employs Facility Sub-Metering which is netted off the Meter Data Submissions for the Facility, these losses are captured in the calculated contribution for the unmetered component of the Facility (figure E[1], right). Where the Facility Sub-Metering captures the energy contribution for each Separately Certified Component of the Facility (and parasitic loads) the difference between the sum total of the Facility Sub-Metering and Meter Data Submissions should be subtracted from the Facility Sub-Metering (figure E[1], left).

**E[A4] Use of SCADA data**

A Market Participant may use SCADA data as an input to calculate the contribution of each Separately Certified Component to the Meter Data Submissions under the methodology required under paragraph Error! Reference source not found.. Figure E[3] shows examples of sources of SCADA data which would be capable of measuring energy in both AC coupled arrangements (figure E[3], left) and DC coupled arrangements (figure E[3], right). AEMO has applied an accuracy requirement for measurement devices which aligns with the Metering Code for alternating type 2 current metering installations.

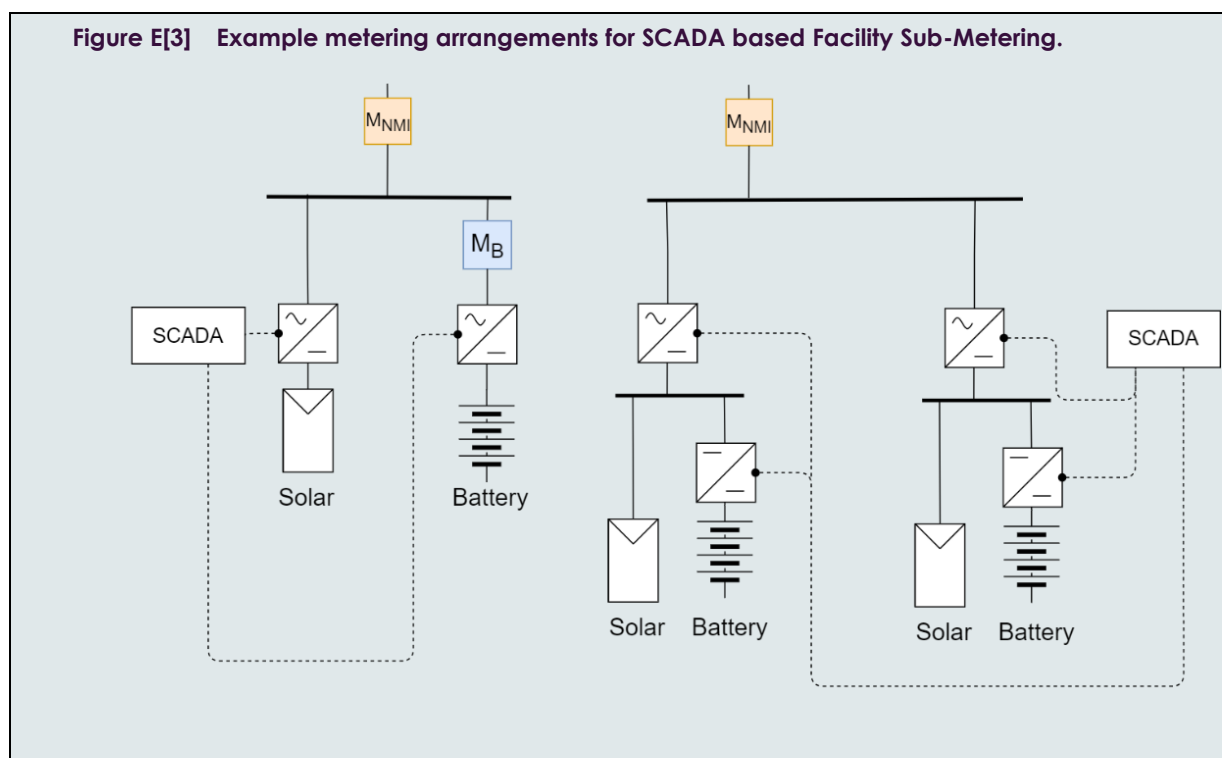

### 3. THE COMMUNICATION REQUIREMENTS AND PROTOCOLS BETWEEN A MARKET PARTICIPANT AND AEMO

- 3.1.1. Facility Sub-Metering data must be submitted in accordance with the WEM Rules to AEMO by email to [wa.capacity@aemo.com](mailto:wa.capacity@aemo.com) in .txt or .csv format where measured using meters in accordance with paragraph 2.2.
- 3.1.2. Where a Market Participant collects Interval Energy Data in accordance with paragraph 2.3.1, that Interval Energy Data must be provided in accordance with the Communications and Control Systems WEM Procedure, where the Interval Energy Data is considered to be Dispatch Data for the purposes of that WEM Procedure.
- 3.1.3. Where a Market Participant collects Interval Energy Data in accordance with paragraph 2.3.1, that Market Participant is considered a Data Communications Provider (DCP), and must meet all relevant requirements of the Communication and Control Systems WEM Procedure.

- 3.1.4. Facility Sub-Metering data submitted under paragraph 3.1.1 must include separate Interval Energy Data for each Separately Certified Component in accordance with the methodology determined under paragraph 2.1.3.
- 3.1.5. Facility Sub-Metering data submitted by a Market Participant in accordance with paragraph 3.1.1 must include Interval Meter Data for all Trading Intervals of each Trading Day for which data is being provided.
- 3.1.6. AEMO may only use data provided from Facility Sub-Metering for the purposes of the processes specified in clause 2.29.13 of the WEM Rules.
- 3.1.7. Where a Market Participant provides data under paragraphs 3.1.1 or 3.1.2, AEMO may assess the accuracy of the submitted data by analysing other data available to it, including:
- (a) Meter Data Submissions;
  - (b) SCADA data;
  - (c) Charge Level of the Electric Storage Resource;
  - (d) weather data, including, but not limited to, ambient temperature, solar irradiance and wind speed at the Facility's location or from a meteorological service providing the equivalent weather data from a location that AEMO considers to be representative of the conditions at the Facility's location;
  - (e) AEMO estimates for sent-out energy for intermittent generating systems in accordance with clause 7.13.6 of the WEM Rules; and
  - (f) any other data that AEMO reasonably expects may facilitate verification of Facility Sub-Metering data.
- 3.1.8. Where AEMO reasonably considers that any data assessed under paragraph 3.1.7 is or may be inaccurate, or has any other reason to consider that the Facility Sub-Metering may not be in accordance with the requirements set out in this Procedure, AEMO may request an audit of the Facility Sub-Metering in accordance with paragraph 4.4.1.

## 4. AUDITING OF FACILITY SUB-METERING

### 4.1. Initial Audit of Facility Sub-Metering

- 4.1.1. A Market Participant who is required to install Facility Sub-Metering in accordance with clause 2.29.12 of the WEM Rules, for a Facility that is yet to enter service, or for a Facility that is yet to complete a Planned Facility Upgrade, must undertake an audit of its installed Facility Sub-Metering prior to the date specified in clause 4.1.26 of the WEM Rules.
- 4.1.2. A Market Participant undertaking an audit of its Facility Sub-Metering in accordance with paragraph 4.1.1 must verify that the installed Facility Sub-Metering complies with the relevant requirements specified in paragraph 2 and the relevant communication requirements specified in paragraph 3 by submitting the information required under paragraph 4.1.3.
- 4.1.3. An audit of a Market Participant's Facility Sub-Metering under paragraph 4.1.1 must be carried out and outlined in a report, prepared and signed by a suitably qualified independent engineer, and must include the following information:
- (a) the identity of the Facility;
  - (b) as-constructed single line diagrams of the Facility, identifying locations of all relevant:
    - (i) major electrical and generation components;
    - (ii) metering installations; and
    - (iii) SCADA measurement locations;
  - (c) where Interval Energy Data is to be sourced from meters in accordance with paragraph 2.2, documents detailing the specifications for all installed electricity meters, including manufacturer datasheets or documents which demonstrate compliance with the requirements of paragraphs 2.2.1, 2.2.2, 2.2.3 and 2.2.4;
  - (d) where Interval Energy Data is to be sourced from SCADA in accordance with paragraph 2.3, the specifications for all devices for which SCADA data is sourced for the purposes of Facility Sub-Metering, including manufacturer datasheets or documents which demonstrate compliance with the requirements of paragraph 2.3.1;
  - (e) commissioning documentation for all installed metering infrastructure;
  - (f) documents describing the process of calculating the contribution of each Separately Certified Component under paragraph 2.1.3 (including any Parasitic Load associated with a Separately Certified Component) to the Facility's Injection or Withdrawal using the Facility Sub-Metering- data and Meter Data Submissions, demonstrating compliance with the requirements of paragraphs 2.1.1, 2.1.2, and 2.1.4;
  - (g) as relevant documents detailing the Market Participants processes for the acquisition, storage and communication to AEMO of Facility Sub-Metering data; and
  - (h) Facility Sub-Metering data (for a minimum period of a Trading Day) in accordance with the format described in paragraphs 3.1.1 and 3.1.2.

- 4.1.4. A Market Participant must submit the report specified in paragraph 4.1.3 to AEMO by email to [wa.capacity@aemo.com.au](mailto:wa.capacity@aemo.com.au).
- 4.1.5. Where AEMO is unable to assess whether the Market Participant associated with the Facility or Planned Facility Upgrade has verified its Facility Sub-Metering in accordance with paragraph 4.1.2 by reviewing the report provided under paragraph 4.1.4, AEMO (acting reasonably) may request additional information from the Market Participant, specifying a time and date for the information to be provided.
- 4.1.6. A Market Participant must provide information requested by AEMO under paragraph 4.1.5 by the time and date specified by AEMO.
- 4.1.7. AEMO must assess whether the Market Participant associated with the Facility or Planned Facility Upgrade has installed Facility Sub-Metering that meets the requirements specified in paragraph 2 and the communication requirements specified in paragraph 3 by reviewing and confirming, the following information:
- (a) documentation provided in accordance with paragraphs 4.1.3 and 4.1.6;
  - (b) consulting with the Network Operator, if required; and
  - (c) taking any other actions it deems necessary to assess the Facility Sub-Metering, within 10 Business Days after receiving the specified information under paragraph 4.1.3, or the additional information under paragraph 4.1.6, as applicable, and must notify the Market Participant of its assessment by email.
- 4.1.8. Where AEMO notifies a Market Participant, in accordance with paragraph 4.1.7, that its Facility Sub-Metering does not meet the requirements of this Procedure, it must provide reasons for its assessment.
- 4.1.9. Where AEMO assesses, in accordance with paragraph 4.1.7, that a Market Participant has not verified its Facility Sub-Metering, the Market Participant must re-submit information in accordance with paragraph 4.1.2, as required.

## **4.2. Subsequent auditing of Facility Sub-Metering**

- 4.2.1. Where AEMO requests a test or audit of a Market Participant's Facility Sub-Metering in accordance with paragraphs 3.1.8 or 4.4.5, AEMO (acting reasonably) must specify the tests or audit to be undertaken, and the time and date by which the associated report under paragraph 4.2.3 must be provided to AEMO.

- 4.2.2. A Market Participant must undertake, using a suitably qualified independent engineer, the tests or audit specified by AEMO under paragraph 4.2.1.
- 4.2.3. A Market Participant must submit to AEMO a report, prepared and signed by a suitably qualified independent engineer, which documents the results of the test or audit undertaken in accordance with paragraph 4.2.2, by the time and date specified under paragraph 4.2.1 unless otherwise agreed with AEMO in writing.
- 4.2.4. Where AEMO is unable to determine whether the Market Participant meets the Facility Sub-Metering requirements upon reviewing the report provided under paragraph 4.2.3, AEMO may request additional information from the Market Participant, specifying a time and date by which the information must be provided.
- 4.2.5. A Market Participant must provide information requested by AEMO under paragraph 4.2.4 by the time and date specified by AEMO.
- 4.2.6. AEMO must, within 10 Business Days after receiving a report provided in accordance with paragraph 4.2.3 or, where relevant, after receiving additional information provided in accordance with paragraph 4.2.5, assess whether a Market Participant's installed Facility Sub-Metering meets the requirements of this Procedure, and must notify the Market Participant of the results of its assessment including, where relevant, any items which do not meet the requirements of this Procedure.

### **4.3. Market Participant identification of outages or malfunctions**

- 4.3.1. A Market Participant must advise AEMO as soon as practicable and submit a rectification plan in accordance with paragraph 4.4.1 of the Procedure, if it becomes aware of a malfunction of its Facility Sub-Metering, or any of its components,.

### **4.4. Rectification of Facility Sub-Metering**

- 4.4.1. Where a Market Participant has:
- (a) notified AEMO under paragraph 4.3.1 of a malfunction of its Facility Sub-Metering; or
  - (b) been notified by AEMO under paragraph 4.2.6 that its Facility Sub-Metering does not meet the requirements of this Procedure,
- it must submit to AEMO a rectification plan within 10 Business Days.
- 4.4.2. A rectification plan must include:
- (a) details of the rectification work to be undertaken in order for the Facility Sub-Metering to meet the requirements of this Procedure; and
  - (b) the date and time by which the Facility Sub-Metering will be rectified, which must be less than 40 Business Days, unless otherwise agreed with AEMO in writing.

- 4.4.3. A Market Participant must undertake rectification works, in accordance with the rectification plan submitted to AEMO, or as otherwise agreed with AEMO.
- 4.4.4. A Market Participant must, within five Business Days following completion of rectification works undertaken in accordance with paragraph 4.4.3, notify AEMO of the completion of rectification works and include reports or data which demonstrate the rectification works have been completed and that the Facility Sub-Metering meets the requirements of this Procedure.
- 4.4.5. Where AEMO receives a notification under paragraph 4.4.4, AEMO may request a test or audit in accordance with paragraph 4.2.1 where it reasonably requires additional verification that the Facility Sub-Metering is in accordance with the requirements of this Procedure.

## APPENDIX A. RELEVANT CLAUSES OF THE WEM RULES

Table 3 details:

- (a) the head of power clauses in the WEM Rules under which the Procedure has been developed; and
- (b) each clause in the WEM Rules requiring an obligation, process or requirement be documented in a WEM Procedure, where the obligation, process or requirement has been documented in this Procedure.

**Table 3 Relevant clauses of the WEM Rules**

Clause
2.29.12.
2.29.13.
2.29.14.
2.29.15.(a)
2.29.15.(b)
2.29.15.(c)
2.29.15.(d)
4.9.3
4.13.10B
4.25
Appendix 9