

# WEM PROCEDURE: RCM CONSTRAINT FORMULATION

PREPARED BY: AEMO  
DOCUMENT REF:  
VERSION: 0.1  
EFFECTIVE DATE:  
STATUS: DRAFT

Approved for distribution and use by:

APPROVED BY: Draft – not approved for distribution or use  
TITLE:

DATE: / / 2022

## VERSION RELEASE HISTORY

Version	Effective Date	Summary of Changes
0.1		Draft Procedure for consultation.

### IMPORTANT NOTICE - EXPLANATORY NOTES

#### Disclaimer

Explanatory notes included in this document as shaded in-line text are provided for explanatory purposes only to assist comprehension and readability. The information contained in these explanatory notes does not constitute legal or business advice and should not be relied on as a substitute for obtaining detailed advice about the Electricity Industry Act 2004 (WA), WEM Rules, or any other applicable laws, procedures or policies. AEMO has made reasonable efforts to ensure the quality of the information, but cannot guarantee its accuracy or completeness.

Accordingly, to the maximum extent permitted by law, AEMO and its officers, employees and consultants involved in the preparation of this document:

- make no representation or warranty, express or implied, as to the currency, accuracy, reliability or completeness of the explanatory information in this document; and
- are not liable (whether by reason of negligence or otherwise) for any statements or representations in this document, or any omissions from it, or for any use or reliance on the information in it.

#### Copyright

© 2022 Australian Energy Market Operator Limited. The material in this publication may be used in accordance with the copyright permissions on AEMO's website.

CONTENTS

1.	INTRODUCTION	4
1.1.	Purpose and scope	4
1.2.	Definitions	5
1.3.	Interpretation	6
1.4.	Related documents	7
2.	FORMULATING RCM CONSTRAINT EQUATIONS	13
2.1.	Selecting RCM Constraint Equations for Peak Demand	13
2.2.	Determining terms and coefficients of an RCM Thermal Constraint Equation	15
2.3.	Formulating Thermal RCM Constraint Equations	16
2.4.	Formulating Non-Thermal RCM Constraint Equations	18
2.5.	Operating Margins	22
3.	PUBLICATION OF RCM CONSTRAINT EQUATIONS	24
4.	NAMING OF RCM CONSTRAINT EQUATIONS AND RCM CONSTRAINT SETS	25
5.	VERIFYING RCM CONSTRAINT EQUATIONS	29
APPENDIX A.	RELEVANT RULE CLAUSES	<b>32</b>

## 1. INTRODUCTION

### 1.1. Purpose and scope

- 1.1.1. This WEM Procedure: RCM Constraint Equation Formulation (Procedure) is made in accordance with AEMO's functions under clause 2.1A.2(h) of the Wholesale Electricity Market Rules (WEM Rules).
- 1.1.2. The *Electricity Industry Act 2004*, the WEM Regulations and the WEM Rules prevail over this Procedure to the extent of any inconsistency.
- 1.1.3. In this Procedure, where obligations are conferred on a Rule Participant, that Rule Participant must comply with the relevant obligations in accordance with clause 2.9.7A or 2.9.8 of the WEM Rules, as applicable.
- 1.1.4. The purpose of this Procedure is to document (with respect to Preliminary RCM Constraint Equations and RCM Constraint Equations):
- (a) the processes to be followed and the methodology to be used by AEMO in determining Constraint Equation terms and coefficients for Network Constraints [clause 2.27A.10(cA)];
  - (b) the processes to be followed and the methodology to be used by AEMO in selecting one or more Constraint Equations to respond to a Network Constraint, including in respect of the location of terms on each side of the Constraint Equation [clause 2.27A.10(cB)];
  - (c) the processes to be followed by AEMO and the matters it must consider in formulating and, where applicable, updating Constraint Equations, (including RCM Constraint Equations), including:
    - (i) the approach to be taken by AEMO in applying:
      - (A) an Operating Margin; and
      - (B) the principles described in clause 2.27A.9; and
    - (ii) the conventions for assigning a unique identifier to Constraint Equations and Constraint Sets [clause 2.27A.10(b)]; and
  - (d) any other processes or procedures relating to Constraints or Network congestion that AEMO considers are reasonably required to enable it to carry out its functions under the WEM Rules [clause 2.27A.10(d)].

1.1.5. Appendix A of this Procedure outlines the head of power clauses that this Procedure is made under, as well as other obligations in the WEM Rules covered by this Procedure.

## 1.2. Definitions

1.2.1. Terms defined in the *Electricity Industry Act 2004*, the WEM Regulations and the WEM Rules have the same meanings in this Procedure unless the context requires otherwise.

1.2.2. The following definitions apply in this Procedure unless the context requires otherwise.

Table 1 Defined Terms

Term	Definition
Coefficient	Means a normalised Sensitivity Factor.
Committed Network Augmentation	Means an augmentation that satisfies commitment criteria applicable to the relevant Preliminary RCM Facility or RCM Facility, as specified by: <ul style="list-style-type: none"> <li>(a) Western Power in its most recent annual planning report; or</li> <li>(b) another Network Operator.</li> </ul>
Conversion Factor	Means a factor that converts the rating of a Network element from an MVA rating to a MW rating.
Facility Dispatch Scenarios	Means multiple independent scenarios, each of which defines how Preliminary RCM Facilities or RCM Facilities could be dispatched at time of Peak Demand.
LHS	Means the left hand side of a Constraint Equation.
Minimum Sensitivity Threshold	Means the minimum Sensitivity Factor for a term to be considered as having a material impact on the formulation of a Constraint Equation.
Non-Thermal Limit Advice	Means Limit Advice provided by a Network Operator to AEMO under clause 2.27A.2 in respect of the Non-Thermal Network Limits of its Network.
Non-Thermal Network Limit	Has the meaning given in the Wholesale Electricity Market Amendment (Tranches 2 and 3 Amendments) Rules 2020.
Non-Thermal RCM Constraint Equation	Means a Preliminary RCM Constraint Equation or RCM Constraint Equation that represents a constraint due to a Non-Thermal Network Limit.
Peak Demand	Means the value determined under clause 4.5.10(a)(iv) and used in the calculation of the Reserve Capacity Requirement for the relevant Capacity Year.
Preliminary Peak Demand	Means the most recently published Peak Demand value.

Term	Definition
Preliminary RCM Facility	Means a Facility which: <ul style="list-style-type: none"> <li>(a) has been assigned Capacity Credits in the previous Reserve Capacity Cycle, and is not expected to cease operation permanently by 1 October of Year 3 of the relevant Reserve Capacity Cycle;</li> <li>(b) has submitted an Expression of Interest under clause 4.2.6 for the relevant Reserve Capacity Cycle;</li> <li>(c) has been assigned Early Certified Reserve Capacity for the relevant Reserve Capacity Cycle; or</li> <li>(d) has applied for Early Certified Reserve Capacity for a future Reserve Capacity Cycle.</li> </ul>
RCM Facility	Means a Facility which has been assigned Certified Reserve Capacity or Early Certified Reserve Capacity for the relevant Reserve Capacity Cycle; or a Facility which has been assigned Early Certified Reserve Capacity for a relevant future Reserve Capacity Cycle.
RHS	Means the right hand side of a Constraint Equation.
Sensitivity Factor	Means the relative impact of an increase in a term in a Preliminary RCM Constraint Equation or RCM Constraint Equation on the power transfer through a monitored element, that is managed by the Preliminary RCM Constraint Equation or RCM Constraint Equation.
Shadow Generator	Means, in the context of a Preliminary RCM Facility or an RCM Facility for which a Network Operator has not provided details of its contribution to a Non-Thermal Network Limit, an existing Preliminary RCM Facility or RCM Facility which AEMO reasonably considers has a similar contribution to that Non-Thermal Network Limit.
Swing Bus	Means a component of load flow analysis that absorbs or supplies power as required by the simulation, to balance supply and demand.
SWIS Demand	Means the net Injection of all Preliminary RCM Facilities or RCM Facilities.
Thermal RCM Constraint Equation	Means a Preliminary RCM Constraint Equation or RCM Constraint Equation that represents a Network Constraint due to a Thermal Network Limit.

### 1.3. Interpretation

1.3.1. The following principles of interpretation apply in this Procedure unless the context requires otherwise.

- (a) Clauses 1.3 to 1.5 of the WEM Rules apply in this Procedure.
- (b) References to time are references to Australian Western Standard Time.
- (c) Terms that are capitalised, but not defined in this Procedure, have the meaning given in the WEM Rules.
- (d) A reference to the WEM Rules or WEM Procedures includes any associated forms required or contemplated by the WEM Rules or WEM Procedures.

- (e) Words expressed in the singular include the plural and vice versa.
- (f) A reference to a paragraph refers to a paragraph of this Procedure.
- (g) A reference to a clause refers to a clause or section of the WEM Rules.
- (h) References to WEM Rules in this Procedure in bold and square brackets [Clause XXX] are included for convenience only, and do not form part of this Procedure.
- (i) Text located in boxes and headed as Explanatory Note X in this Procedure is included by way of explanation only and does not form part of this Procedure. The Procedure prevails to the extent of any inconsistency with the explanatory notes contained within it.
- (j) The body of this Procedure prevails to the extent of any inconsistency with the appendices, schedules, annexures or attachments contained within this document.

1.3.2. The following additional principles of interpretation apply in this Procedure unless the context requires otherwise:

- (a) Unless specified otherwise, a reference to the RCM Constraint Equations is also a reference to the Preliminary RCM Constraint Equations.
- (b) Unless specified otherwise, a reference to the RCM Constraint Sets is also a reference to the Preliminary RCM Constraint Sets.
- (c) Unless specified otherwise, a reference to the Thermal RCM Constraint Equations is also a reference to the Preliminary Thermal RCM Constraint Equations.
- (d) Unless specified otherwise, a reference to the Non-Thermal RCM Constraint Equations is also a reference to the Preliminary Non-Thermal RCM Constraint Equations.
- (e) Unless specified otherwise, a reference to the Peak Demand is also a reference to the Preliminary Peak Demand.
- (f) Unless specified otherwise, a reference to the RCM Facilities is also a reference to the Preliminary RCM Facilities.
- (g) Unless specified otherwise, a reference to the RCM Constraint Equations is also a reference to the Thermal RCM Constraint Equations and Non-Thermal RCM Constraint Equations.

## 1.4. Related documents

1.4.1. The documents in Table 2 are associated with this Procedure.

**Table 2 Related documents**

Reference	Title	Location
WEM Rules	WEM Rules	<a href="#">Energy Policy WA Website</a>
Technical Rules	Technical Rules	<a href="#">Economic Regulation Authority Website</a>
WEM Procedure	RCM Limit Advice Requirements	<a href="#">WEM Website</a>
WEM Procedure	Network Access Quantity Model	<a href="#">WEM Website</a>
WEM Procedure	Development of RCM Limit Advice (maintained by Western Power)	Western Power website

## **E[A] Process Overview**

This explanatory note summarises the overall processes described in this Procedure.

### **E[A1] Summary**

Constraint is defined in the WEM Rules and, for the purposes of this Procedure, is relevantly defined as a Network Constraint.

Examples of Constraints in the SWIS include but are not limited to:

- (a) maximum power transfer capacity (rating) of a transmission line;
- (b) maximum power transfer capability across a specific group of transmission lines to ensure power system stability; and
- (c) minimum stable operating level of a generation unit.

Note that only Network Constraints are relevant to RCM Constraint Equations.

### **E[A2] RCM Constraint Equations**

RCM Constraint Equations are formulated by AEMO under clauses 4.4B.4 and 2.27A.7. They are used by AEMO to represent Network Constraints that apply in the Network Access Quantity Model, formulated by AEMO in accordance with clause 4.15.6 for the purposes of determining a Network Access Quantity for a Facility, using the methodology described in Appendix 3 of the WEM Rules.

RCM Constraint Equations are formulated in a specific manner for input to the Network Access Quantity Model. The methodology that applies is the same for both Preliminary RCM Constraint Equations and RCM Constraint Equations, except that Preliminary RCM Constraint Equations account for Preliminary RCM Facilities and Preliminary Peak Demand, whereas RCM Constraint Equations account for RCM Facilities and Peak Demand.

RCM Constraint Equations are created at different times in the Reserve Capacity Cycle based on the availability of information at the time.

Numerous RCM Constraint Equations can apply in the Network Access Quantity Model, each of which represents a unique Constraint in the SWIS.

This Procedure describes the terminology, conventions, and process by which mathematical expressions of physical limits of the Network are converted into RCM Constraint Equations, which are required as an input to the Network Access Quantity Model.

### **E[A3] Types of RCM Constraint Equations**

RCM Constraint Equations include Thermal RCM Constraint Equations and Non-Thermal RCM Constraint Equations.

AEMO uses RCM Limit Advice provided by the Network Operator under clause 4.4B.5 to formulate Thermal RCM Constraint Equations in accordance with clause 4.4B.4(a). These Thermal RCM Constraint Equations are used to manage power transfers so that the Network elements do not exceed the temperature-dependent ratings at 41 degrees Celsius.

Non-Thermal Limit Advice includes Network Limits that are not Thermal Network Limits, covering dynamic security issues such as Network voltage and oscillatory stability. If a Network Operator has



provided AEMO with Non-Thermal Limit Advice that is applicable under Peak Demand conditions, AEMO must use this information to formulate Non-Thermal RCM Constraint Equations.

Operationally, AEMO also uses other types of Constraint Equations to manage Power System Security depending on system conditions. These may include:

- (a) Constraint Equations that apply under outage conditions;
- (b) Constraint Equations that manage Essential System Services; and
- (c) condition-specific Constraint Equations such as those used to manage Rate of Change of Frequency (RoCoF).

These types of Constraint Equations are not considered in the Network Access Quantity Model, and are not represented in the RCM Constraint Equations.

#### **E[A4] Process flow**

Using the RCM Limit Advice and any non-Thermal Limit Advice provided by a Network Operator, AEMO first determines which RCM Constraint Equations need to be formulated for input to the Network Access Quantity Model, using processes described in paragraph 2.1.

RCM Constraint Equations are then formulated by AEMO according to the formulation principles and processes described in paragraphs 2.2 to 2.5.

## **E[B] Basic Format of RCM Constraint Equations**

### **E[B1] Basic Structure**

RCM Constraint Equations are comprised of three basic elements: a Left-Hand Side (LHS), an operator, and a Right-Hand Side (RHS). Equation 1 shows an example of the basic format, using the less than or equal to ( $\leq$ ) operator:

Equation 1

$$LHS \leq RHS$$

The LHS and RHS are comprised of a mathematical expression which includes one or more terms. There are a variety of terms that can appear in the RCM Constraint Equations, which include but are not limited to:

- (a) the generation output or demand from a Facility;
- (b) Peak Demand;
- (c) local area demand;
- (d) transmission line ratings;
- (e) fixed constants; and
- (f) conditional constants, including constants that might only apply depending on the status of a Facility.

Note that appearance of a term on the LHS or the RHS of an RCM Constraint Equation, is dependent on the type of term.

### **E[B2] Left-Hand Side Terms (LHS)**

LHS terms generally include RCM Facilities that can respond to Dispatch Instructions. These terms are able to be controlled by the Network Access Quantity Model and include Scheduled Facilities, Semi-Scheduled Facilities and Demand Side Programmes only (refer to paragraph 2.3.2(c)).

Terms including Non-Scheduled Facilities and fixed values (i.e., constants) which cannot vary by way of Dispatch Instruction, will not appear on the LHS and are not directly controllable by the Network Access Quantity Model.

### **E[B3] Right-Hand Side Terms (RHS)**

The RHS includes all other terms that cannot be included on the LHS. Examples include:

- (a) output from Non-Scheduled Facilities;
- (b) fixed constants; and
- (c) conditional constants.

### **E[B4] Coefficients**

Each term on both the LHS and RHS of an RCM Constraint Equation has a unique coefficient. The coefficient provides a measure of the relative impact of each term on the Network Constraint. For example, if the coefficient for a particular term on the LHS is 1, that term will have twice the impact on management of the Network Constraint when compared with another term of the LHS with a coefficient of 0.5.

In the Central Dispatch Process, coefficients may be normalised such that the absolute value of the largest coefficient on the LHS is 1. Normalisation preserves the relative impact of all the terms in a Network Constraint by scaling all the Sensitivity Factors by the same multiplier.

Note that for the purpose of RCM Constraint Equations, it is not necessary for AEMO to normalise the coefficient. Refer to paragraph 2.2 for more information.

### **E[B5] Operator**

An operator is a conditional requirement between the LHS and RHS of an RCM Constraint Equation and can be one of the following:

- (a)  $\leq$  (less than or equal);
- (b)  $=$  (equal); or
- (c)  $\geq$  (greater than or equal)

An operator describes the relationship between the LHS and RHS according to their usual mathematical definition. The Operator for most RCM Constraint Equations is less than or equal to ( $\leq$ ) but other Operators such as greater than ( $\geq$ ) can sometimes be used in special circumstances, such as modelling of Network Control Services.

### **E[B6] Representation of LHS, RHS and coefficients**

In this Procedure, terms (including variables and constants) and coefficients are indicated in mathematical script by upper case letters (G, L and F) and lower case (a, b and c) letters, respectively.

RCM Constraint Equations are represented by a monitored element – contingency element pair. The monitored element is a single transmission element or a group of transmission elements on which power transfer is being controlled, and the contingent element is a part of the transmission system that is assumed to have experienced an unplanned outage (a credible contingency). In some cases, RCM Constraint Equations can apply for a monitored element without a contingency.

Figure 1 shows a basic example of how an RCM Constraint Equation may be expressed to avoid thermal overload of a specific monitored element (transmission line  $L_1$ ) in the event of an unplanned outage of the contingent element (transmission line  $L_2$ ). In this example:

- (a) there are two Scheduled Generators,  $G_1$  and  $G_2$ ;
- (b) the rating of the monitored transmission line  $L_1$  is  $R_1$ ;
- (c) the power transfer on  $L_1$  after the contingency on  $L_2$  must be less than or equal to  $R_1$ ;
- (d) after a contingency on  $L_2$ :
  - 60% of the power from  $G_1$  is transferred on  $L_1$  and the remaining 40% of the power from  $G_1$  is transferred through other parts of the SWIS network between  $L_3$  and  $L_4$ ;
  - 40% of the power from  $G_2$  is transferred on  $L_1$  and the remaining 60% of the power from  $G_2$  is transferred through other parts of the SWIS network between  $L_3$  and  $L_4$ ; and
  - 1.5% of the SWIS Demand is transferred on  $L_1$ ;
- (e) the contribution of  $G_1$ ,  $G_2$  and SWIS Demand, PD to power transfer on  $L_1$  following a contingency on  $L_2$ , can be expressed as  $a*G_1 + b*G_2 + c*PD$ , where the coefficients for  $G_1$ ,  $G_2$  and PD (a, b and c) are equal to 0.6, 0.4 and 0.015, respectively; and
- (f) the power transfer on  $L_1$  after the contingency on  $L_2$  can be expressed as  $0.6*G_1 + 0.4*G_2 + 0.015*PD$ , which must be less than or equal to  $R_1$ . Using the LHS and RHS notation and

noting that LHS terms only include Facilities which can respond to Dispatch Instructions, the constraint can be expressed as shown in Equation 2:

Equation 2

$$0.6 * G_1 + 0.4 * G_2 \leq 1 * R_1 - 0.015 * PD$$

Figure 1 Network flow example for the evaluation of an RCM Constraint Equation expression.

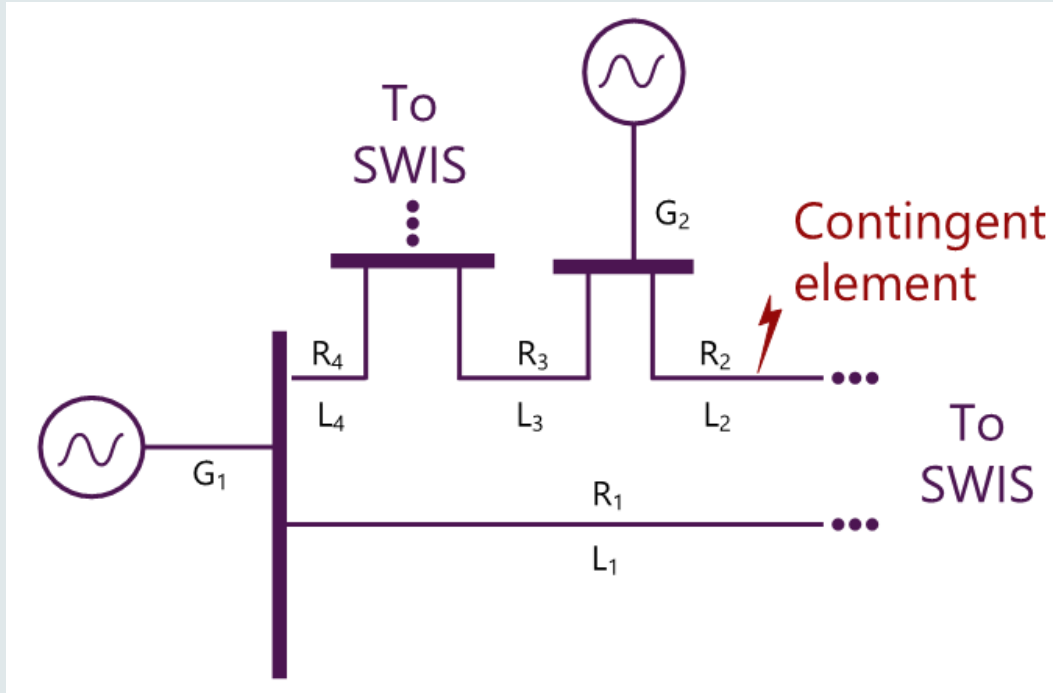

### E[B7] Thermal RCM Constraint Equations

Thermal RCM Constraint Equations are a category of Constraint Equations for Network congestion, used to control power system transfers to avoid thermal overload on transmission elements (i.e., prevent a transmission element from overheating).

These Constraint Equations are formulated based on RCM Limit Advice provided to AEMO by a Network Operator under clause 4.4B.1.

### E[B8] Non-Thermal RCM Constraint Equations

Non-Thermal RCM Constraint Equations are a category of Constraint Equations for Network congestion, used to manage power system transfers to avoid non-thermal limitations on transmission elements, or groups of transmission elements. This type of Network Constraint Equation may be used to prevent voltage instability or loss of synchronism in the power system, for example.

These Network Constraint Equations are formulated by AEMO based on Non-Thermal Network Limits, provided to AEMO, in the form of Limit Advice, by Network Operators under clause 2.27A.1.

## 2. FORMULATING RCM CONSTRAINT EQUATIONS

### 2.1. Selecting RCM Constraint Equations for Peak Demand

#### **E[A] Network Modelling**

##### **E[A1] Network Coverage**

To model RCM Constraint Equations for Peak Demand conditions, only a selection of equations are required. It is therefore unnecessary to formulate RCM Constraint Equations to control power transfer on every transmission element, or group of transmission elements for every possible contingency. This is because:

- (a) in some transmission network elements sufficient network capacity is available under all reasonable Facility Dispatch Scenarios;
- (b) there are many areas of the network where non-thermal network limitations are not evident under these conditions; and
- (c) RCM Constraint Equations are only required to control the power transfer on all transmission elements which could reasonably result in a constraint on an RCM Facility under Peak Demand conditions.

AEMO uses a detailed model of the power system and Facility Dispatch Scenarios to determine which Thermal RCM Constraint Equations are required (refer to paragraph 2.12).

AEMO will generally formulate Non-Thermal RCM Constraint Equations to account for all non-thermal Limit Advice provided by a Network Operator that are applicable under Peak Demand conditions and may use a 'Shadow Generator' approach to account for the impact of future Facilities (refer to paragraph E[E] for 'Shadow Generator' approach).

##### **E[A2] Reducing the number of contingent elements**

It is possible that the power transfer on a certain transmission element (monitored element) can be exceeded in the event of any one of a number of different contingencies occurring (contingent element). In some cases, one particular contingency can result in the highest power transfer on the monitored element under all circumstances. Where this occurs, an RCM Constraint Equation may only be formulated for the worst-case contingent element, which results in the highest power transfer on the monitored element under all Facility Dispatch Scenarios. This will be the Constraint which causes changes in the output of one or more RCM Facilities in the Network Access Quantity Model ahead of any others that are less onerous, allowing AEMO to reduce the total number of RCM Constraint Equations that apply.

AEMO uses a detailed model of the power system and Facility Dispatch Scenarios to determine if one or more RCM Constraint Equations can be discarded on the basis they will be benign in the presence of more limiting RCM Constraint Equations.

- 2.1.1. AEMO must formulate Thermal RCM Constraint Equations for each RCM Limit Advice provided by Network Operators under clause 4.4B.5 of WEM Rules, unless in its reasonable opinion, the RCM Limit Advice Network Limits are unlikely to result in a Facility being subject to a Constraint under Peak Demand conditions.

- 2.1.2. Where the power transfer on a Network element is exceeded for a number of different contingencies, AEMO may, in its reasonable opinion, only formulate RCM Constraint Equations for the worst-case contingency that results in the highest power transfer on the Network element under all considered Facility Dispatch Scenarios in paragraph 2.1.3(e).
- 2.1.3. In assessing if AEMO must formulate an RCM Constraint Equation in paragraphs 2.1.1 and 2.1.2, AEMO must prepare power system models that include:
- (a) Peak Demand;
  - (b) RCM Facilities;
  - (c) information provided by each Network Operator under clauses 4.4B.5(a), 4.4B.5(b), 4.4B.5(c) and 4.4B.5(d);
  - (d) the matters that must be taken into account in clause 4.15.8; and
  - (e) one or more Facility Dispatch Scenarios which, in its reasonable opinion, would be most likely to identify Network Constraints that could result in a Facility Constraint under Peak Demand conditions.

### **E[B] Preparing power system models**

The information provided by Network Operators under clause 4.4B.5 allows AEMO to:

- (a) distribute the Peak Demand among the various Electrical Locations in the Network allowing the locational impacts of demand on power transfer on the transmission Network to be represented in the model;
- (b) model the estimated configuration of the Network at time of Peak Demand accounting for Network elements likely to be in service and not in service; and
- (c) model the thermal ratings of the transmission Network at an ambient temperature of 41 degrees Celsius so that overloads on the transmission Network can be identified in the model.

AEMO must also take into account the matters specified in clause 4.15.8 of WEM Rules when preparing the power system models in paragraph 2.1.2, allowing AEMO to account for the impact of Committed Network Augmentations, committed Network changes, and expected retirement of Facilities, on the power transfer on the transmission Network.

- 2.1.4. AEMO must formulate the Non-Thermal RCM Constraint Equations for each Non-Thermal Limit Advice provided by a Network Operator under clause 2.27A.3, unless:
- (a) A Network Operator advises that the Non-Thermal Limit Advice is not applicable under Peak Demand conditions;
  - (b) AEMO's (acting reasonably) considers the Non-Thermal Limit Advice is not applicable under Peak Demand conditions; or
  - (c) AEMO (acting reasonably) considers the Non-Thermal Limit Advice is unlikely to result in a Network Constraint affecting an RCM Facility at Peak Demand, using the power system models specified in paragraph 2.1.3.

## 2.2. Determining terms and coefficients of an RCM Thermal Constraint Equation

### E[C] Sensitivity Factors

The coefficients in an RCM Thermal Constraint Equation are also known as Sensitivity Factors. The Sensitivity Factors are determined using power system studies specified under paragraph 2.2. For an individual term, the Sensitivity Factor represents the contribution that the term has on the power transfer on a particular transmission element under certain operating conditions. Featuring terms with very small contributions in an RCM Constraint Equation may result in the equation being unnecessarily complex and so AEMO determines a Minimum Sensitivity Threshold to apply in order to remove terms that have no impact on NAQ outcome and simplify the calculation, if necessary.

Note that in Central Dispatch Process, the Sensitivity Factors may be normalised in order to move any LHS terms with normalised coefficients less than 0.07 to RHS, to mitigate the risk that the Central Dispatch Process may choose to violate the Constraint Equation in preference to dispatching high-priced offers. The risk is not relevant to Network Access Model and it is therefore not necessary for AEMO to normalise the Sensitivity Factors.

- 2.2.1. AEMO must formulate the Thermal RCM Constraint Equations in accordance with the processes specified in paragraphs 2.2.2 to 2.2.6, unless in its reasonable opinion, a deviation from any parts of the processes is necessary for formulating more appropriate Thermal RCM Constraint Equations, which may include circumstances described in paragraph 5.1.2(c)(ii).
- 2.2.2. AEMO must determine the Sensitivity Factors for all terms in the Thermal RCM Constraint Equations using the power system models prepared under paragraph 2.1.3.
- 2.2.3. When determining the Sensitivity Factors in paragraph 2.2.2, AEMO may add additional or alternative Facility Dispatch Scenarios to the power system models described in paragraph 2.1.3, to result in more appropriate Sensitivity Factors.
- 2.2.4. For each Thermal RCM Constraint Equation, AEMO must determine the Sensitivity Factor for each relevant Facility, the Sensitivity Factor for the SWIS Demand term, and the constant value, by following the steps below:
- (a) removing the contingent element, and all consequential elements from service;
  - (b) identifying the power flow in MW on the monitored element;
  - (c) using load flow simulation and assigning the Swing Bus to be the Reference Node in the power system model, determine the Sensitivity Factor for each RCM Facility as:

Equation 3

$$S_i = \Delta P_M / \Delta P_i$$

Where:

- $S_i$  is the Sensitivity Factor for Facility  $i$ ;
- $\Delta P_i$  is an Injection of MW exclusively by Facility  $i$ , or in the case of Demand Side Programmes a Withdrawal of MW exclusively.

- $\Delta P_M$  is the change in power flow in MW through the monitored element following  $\Delta P_i$ ; and
- (d) using load flow simulation, identifying the Sensitivity Factor for the SWIS Demand term by increasing the load demand at all relevant locations, including relevant Electrical Locations, and calculating the difference in power flow on the monitored element with respect to the difference in SWIS Demand:

Equation 4

$$S_{SWIS} = (ME' - ME) / (PD' - PD)$$

Where:

- $ME'$  is the power flow on the monitored element after increasing SWIS Demand;
- $ME$  is the power flow on the monitored element under Peak Demand conditions;
- $PD'$  is the SWIS Demand after increasing demand beyond SWIS Demand;
- $PD$  is the initial SWIS Demand; and
- $S_{SWIS}$  is the Sensitivity Factor for the SWIS Demand term;
- (e) returning the load demand at relevant locations in paragraph 2.2.4(d) to the initial value;
- (f) calculating a constant value as the error between the sum of all Scheduled Facilities, Semi-Scheduled Facilities, Non-Scheduled Facilities and Demand Side Programmes and SWIS Demand multiplied by their respective Sensitivity Factors, and the flow on the monitored element measured at paragraph 2.2.4(b):

Equation 5

$$constant = monitored\ element\ flow - \left( \sum_{i=1}^n SiPi + S_{SWIS} * PD \right)$$

where:

- $Si$  is the Sensitivity Factor for Facility  $i$
- $Pi$  is the output (MW) for Facility  $i$ .
- (g) returning the contingent element in paragraph 2.2.4(a) to service.

2.2.5. AEMO must assume the Minimum Sensitivity Threshold for the Sensitivity Factor of any Facility to be 0.01.

2.2.6. Where the absolute value of the Sensitivity Factor of any Facility is less than the Minimum Sensitivity Threshold specified in paragraph 2.2.5, AEMO may exclude that Facility from the relevant Thermal RCM Constraint Equation.

## 2.3. Formulating Thermal RCM Constraint Equations

2.3.1. AEMO must formulate the Thermal RCM Constraint Equations in accordance with the processes specified in paragraph 2.3.2, unless in its reasonable opinion, a deviation from any parts of the processes is necessary for formulating more appropriate Thermal RCM Constraint Equations, which may include but are not limited to:

- (a) circumstances where a Network Control Service or Non-Co-optimised Essential System Service must be reflected in the formulation of the Constraint Equation; or



- (b) circumstances described in paragraph 5.1.2(c)(ii).

2.3.2. In formulating the Thermal RCM Constraint Equations, AEMO must,

- (a) use the terms, including the Sensitivity Factors and constant, determined in paragraph 2.2.4, and apply the Minimum Sensitivity Threshold in paragraph 2.2.6 to determine the:
  - (i) initial LHS of each Thermal RCM Constraint Equation, which is the summation of all terms multiplied by their respective Sensitivity Factors, and the constant; and
  - (ii) initial RHS, which is the Thermal Network Limit provided in the Thermal RCM Limit Advice (also known as the rating of the monitored element, *Rm*), multiplied by a Conversion Factor specified in paragraph 2.5.3;
- (b) substitute the initial LHS and RHS in paragraph 2.3.2(a) to yield the initial form of Thermal RCM Constraint Equations; and
- (c) include the RCM Facilities or terms that can respond to Dispatch Instructions in the LHS, and move other terms to the RHS.

DRAFT

**E[D] Example**

Formulating initial LHS and RHS:

Equation 6

$$LHS = (a * A + b * B + c * C + d * D + x * PD) + 1 * constant$$

where:

- Lower case letters (*a* through *d*) and upper case letters (*A* through *D*) denote the Sensitivity Factor and term for each Facility, respectively;
- Lower case *x* denotes the Sensitivity Factor for SWIS Demand;
- *PD* denotes the SWIS Demand considered for a Facility Dispatch Scenario; and
- *constant* is the constant value calculated in paragraph 2.2.4.

Equation 7

$$RHS = conversion\ factor * Rm$$

where:

- *Rm* is the Rating of the monitored element; and
- *conversion factor* is the Conversion Factor specified in paragraph 2.5.3.

A Thermal RCM Constraint Equation is generally of the form of  $LHS \leq RHS$ ; substituting initial LHS and RHS to  $LHS \leq RHS$ :

Equation 8

$$a * A + b * B + c * C + d * D + x * PD + 1 * constant \leq conversion\ factor * Rm$$

Assuming terms A, B, C are Scheduled Facilities and term D is a Non-Scheduled Facility, Thermal RCM Constraint Equation in Equation 8 is rearranged as shown in Error! Reference source not found.:

Equation 9

$$a * A + b * B + c * C \leq conversion\ factor * Rm - 1 * constant - x * PD - d * D$$

## 2.4. Formulating Non-Thermal RCM Constraint Equations

2.4.1. Where AEMO must formulate a Non-Thermal RCM Constraint Equation under paragraph 2.1.4, AEMO may:

- (a) add an appropriate Operating Margin in accordance with paragraph 2.5.4;
- (b) apply the approach specified under paragraph 2.3 where relevant;
- (c) re-orient a Limit Equation to the Reference Node; or
- (d) re-express a Limit Equation as multiple Non-Thermal Constraint Equations;

2.4.2. Where a Network Operator is unable to provide Non-Thermal Network Limits for an RCM Facility specified under clause 4.4B.4(b), AEMO may:

- (a) in order to represent the impact of the Facility on an existing Non-Thermal Network Limit, assign a coefficient for the Facility in a Non-Thermal Network Limit, based on the coefficients of one or more existing RCM Facilities ('Shadow Generators') considered in a Non-Thermal Network Limit; or
- (b) where AEMO determines that the approach specified in paragraph 2.4.2 (a) will not reasonably reflect the contribution of a Facility to a Non-Thermal Network Limit, exclude that Facility from the relevant RCM Non-Thermal Constraint Equation.

2.4.3. To determine if the approach specified in paragraph 2.4.2(a) will not reasonably reflect the contribution of an RCM Facility to a Non-Thermal Network Limit, AEMO may consider:

- (a) the location of the monitored element or group of monitored elements in the Non-Thermal Network Limit and the contingent element, where relevant;
- (b) the electrical distance between that RCM Facility and the potential Shadow Generator;
- (c) the difference in technology between that RCM Facility and the potential Shadow Generator;
- (d) the difference in capacity between that RCM Facility and the potential Shadow Generator; and
- (e) any other factors deemed relevant by AEMO.

**E[E] 'Shadow Generator' approach**

The Shadow Generator approach assumes an RCM Facility specified under clause 4.4B.4(b) will have an impact on a Non-Thermal Network Limit in a consistent manner to an existing RCM Facility that is electrically nearby. This allows the RCM Facility to “shadow” the impact of the existing RCM Facility ('Shadow Generator') by assigning the same or similar coefficients. AEMO may also determine that an RCM Facility is best represented using a unique coefficient in a Non-Thermal Network Limit based on the coefficients of more than one Shadow Generator.

Examples of circumstances where the Shadow Generator approach may not be appropriate include but are not limited to:

- (a) if the monitored element or group of monitored elements in the Non-Thermal Network Limit is electrically between the RCM Facility and the potential Shadow Generator, it is likely that one of them contributes to the flow on the monitored element while the other does not. If the contingent element is the line electrically between them, especially if there is not a parallel line, the RCM Facility and the potential Shadow Generator may also affect the Non-Thermal Network Limit very differently.
- (b) if the distance is large enough that the contribution of the RCM Facility to the Non-Thermal Network Limit, or flow on the monitored element is significantly different to the potential Shadow Generator, the Shadow Generator approach may not be viable.
- (c) where a Non-Thermal Network Limit relates to a specific type of Facility Technology Type, such as a limit on inverter-based generation, it may not be appropriate to use an existing inverter-based RCM Facility as the Shadow Generator for a synchronous RCM Facility.
- (d) if there are considerable differences in the capacity between the RCM Facility and the Shadow Generator (e.g., the reactive power capability), the performance is also likely to be considerably different, in which case the Shadow Generator approach may not be viable.

## **E[F] Excluding the impact of an RCM Facility on a Non-Thermal Network Limit**

If a Facility has an impact on a Non-Thermal Network Limit, and Constraint Equations are required to manage the limit operationally, a Network Operator must provide the relevant Non-Thermal Network Limit to AEMO under clause 2.27A.3, and in accordance with the timeline specified in WEM Procedure: Limit Advice Requirements.

For a Reserve Capacity Cycle however, a Network Operator may not be able to provide the relevant Non-Thermal Network Limits for an RCM Facility for AEMO to formulate RCM Constraint Equations under clause 2.27A.7(a).

Under such circumstances, AEMO may exclude the impact of an RCM Facility to a Non-Thermal Network Limit. This decision may have implications for the NAQ process, including but not limited to:

- (a) a Facility may be assigned a greater quantity of NAQ than it would subsequently receive if relevant Non-Thermal Limits impacted the Facility operationally. Contribution to Non-Thermal Limits in subsequent years may therefore reduce the NAQ assigned. Decisions made by the relevant Market Participant based on the Network Access Quantity allocated in Year 1 of the Reserve Capacity Cycle, may not be reflective of future allocations<sup>1</sup>.
- (b) For at least 2 years, other RCM Facilities applying for Capacity Credits for the same Capacity Year could potentially receive lower Network Access Quantities due to AEMO assigning a higher Network Access Quantity to this RCM Facility in Year 1 of the Reserve Capacity Cycle.
- (c) The Network Access Quantity assigned to a new Facility could reflect more than what it could actually produce at the time of system peak demand 2 years later with the Constraint Equation binding operationally, which is a risk to ensuring sufficient capacity is obtained. This will self-correct in Year 3 of the Reserve Capacity Cycle when relevant Constraints are included to appropriately reflect Network Access Quantity.

<sup>1</sup> Note that there are other reasons why an assigned NAQ reduces periodically. It is often a combination of reasons and hard to attribute to a single reason. These reasons include, but are not limited to, reduction in performance of a Facility at 41 degrees Celsius, reduction in MW output at Peak Demand for Semi-Scheduled Facilities, as determined by Relevant Level Methodology; changes in local load demand and Network configuration, which lead to increase in Network congestion and reduction in NAQ assignment.

**E[G] Operating Margin concepts****E[G1] Thermal RCM Constraint Equation Operating Margins**

While the measurement and use of MVA quantities to manage Network Limits is more physically accurate, the Network Access Quantity Model makes use of Facility Dispatch Scenarios in MW to meet the Peak Demand, which is also specified in MW.

Thermal Network Limits under clause 4.4B.3 are typically specified by a Network Operator as a rating on a transmission element in Amps at an ambient temperature of 41 degrees Celsius, which can then be easily converted to MVA. To ensure consistency with the way all terms in an RCM Constraint Equation are treated, the rating is converted by AEMO from MVA to MW. This is generally achieved by multiplying the rating by 0.95. AEMO has determined 0.95 to be an appropriate Conversion Factor for most parts of the Network, noting that most Facilities operate in a relatively narrow Power Factor range within 0.95 leading to 0.95 lagging, which produces similar power factors for power flows on the Network.

AEMO may determine that an alternative Conversion Factor is required to convert a rating from MVA to MW for one or more monitored elements in Thermal RCM Constraint Equation. This may occur where AEMO is of the view that a Conversion Factor of 0.95 is inappropriate for a specific transmission element based on its operational experience under high demand conditions. Paragraph 5 specifies how AEMO may verify and adjust the RCM Constraint Equations.

**E[G2] Non-Thermal RCM Constraint Equation Operating Margins**

Non-Thermal Network Limits are generally provided by Network Operators as a mathematical expression that defines a non-thermal power transfer limit across a monitored element (being a single transmission element or group of transmission elements) in MW. In this case AEMO does not typically apply an Operating Margin to the non-thermal Limit Advice, and instead, uses it directly in the formulation of a Non-Thermal RCM Constraint Equation.

AEMO may, on a case by case basis, determine that an Operating Margin is required to apply to Non-Thermal Network Limits, depending on the specific information received by a Network Operator describing the Non-Thermal Network Limit.

**2.5. Operating Margins**

- 2.5.1. Subject to paragraph 2.5.2, AEMO must follow the approach specified in paragraphs 2.5.3 and 2.5.4 when applying an Operating Margin to Thermal RCM Constraint Equations under clause 2.27A.10(b)(i)(1) of the WEM Rules.
- 2.5.2. AEMO (acting reasonably), may vary the Operating Margin for selected Thermal RCM Constraint Equations if it determines a deviation from any parts of the approach is necessary for formulating more appropriate Thermal RCM Constraint Equations. This may include, but is not limited to circumstances described in paragraphs 5.1.2(c)(ii) and 5.1.5(d)(ii).
- 2.5.3. AEMO must apply an Operating Margin to the Thermal RCM Constraint Equations by multiplying the thermal rating of the monitored element (in MVA) with a Conversion Factor of 0.95 unless, AEMO (acting reasonably) determines another Conversion Factor is more appropriate for a specific Thermal RCM Constraint Equation.

- 2.5.4. AEMO must apply an Operating Margin of zero to Non-Thermal RCM Constraint Equations unless, AEMO (acting reasonably) determines another Operating Margin is more appropriate for a specific Non-Thermal RCM Constraint Equation.

DRAFT

### **3. PUBLISHING RCM CONSTRAINT EQUATIONS**

- 3.1.1. For a relevant Reserve Capacity Cycle, AEMO must publish the following information in the Constraints Library by the date and time specified in clause 4.4B.6 or (for the 2022 Reserve Capacity Cycle only) as modified by AEMO under clause 1.36B or (for the 2023 and subsequent Reserve Capacity Cycles) as modified by AEMO under clause 4.1.1C:
- (a) the information provided by each Network Operator under clause 4.4B.5; and
  - (b) Preliminary RCM Constraint Equations.
- 3.1.2. For a relevant Reserve Capacity Cycle, AEMO must publish the information required to be published under clause 4.15.16(a), including the RCM Constraint Equations, by the date and time specified in clause 4.1.16A, or (for the 2022 Reserve Capacity Cycle only) as modified by AEMO under clause 1.36B or (for the 2023 and subsequent Reserve Capacity Cycles) as modified by AEMO under clause 4.1.1C.
- 3.1.3. When information specified in paragraphs 3.1.1 and 3.1.2 becomes available for a Reserve Capacity Cycle, AEMO must use reasonable endeavours to update the Constraints Library, by the time specified in paragraphs 3.1.1 and 3.1.2.
- 3.1.4. AEMO must notify Rule Participants via email as soon as practicable when updates in paragraph 3.1.3 are available.



#### 4. NAMING OF RCM CONSTRAINT EQUATIONS AND RCM CONSTRAINT SETS

4.1.1. AEMO must compose the unique identifier for RCM Constraint Equations as an ordered series of the following components, each separated by a hyphen [2.27A.10(b)(ii)]:

- (a) A prefix code comprised of the following elements, each separated by a hyphen:
  - (i) "RCM" for RCM Constraint Equations or "P-RCM" for Preliminary RCM Constraint Equations;
  - (ii) "RCC" and followed by the RCM Capacity Cycle which the Preliminary RCM Constraint Equations or RCM Constraint Equation applies;
  - (iii) "CY" and followed by the RCM Capacity Year which the Preliminary RCM Constraint Equations or RCM Constraint Equation applies; and
  - (iv) the letter "S" followed by a number indicating the relevant step of Appendix 3 of the WEM Rules, in which the RCM Constraint Equation first applies to for the relevant RCM Capacity Year.
- (b) A cause ID which indicates the type of RCM Limit Advice or Non-Thermal Network Limit being managed by the RCM Constraint Equation, as per Table 3.

**Table 3 Cause ID**

Cause ID	Cause ID description
>	Thermal Limit
:	Transient or oscillatory stability
^	Voltage stability
*	Any other limit that does not fit into the above categories

- (c) A monitored element which indicates the transmission element, or group of transmission elements for which Power Flow is being controlled by the RCM Constraint Equation.
- (d) A contingent element which describes the relevant contingency the RCM Constraint Equation is protecting the monitored element against. A contingent element defined as "NIL" applies where there is no contingency involved.

4.1.2. AEMO must compose the unique identifier for RCM Constraint Sets as an ordered series of the following components, each separated by a hyphen [2.27A.10(b)(ii)]:

- (a) "RCM" for an RCM Constraint Set or "P-RCM" for a Preliminary RCM Constraint Set.
- (b) "RCC" and followed by the RCM Capacity Cycle which the Preliminary RCM Constraint Equations or RCM Constraint Equation applies;
- (c) "CY" and followed by the RCM Capacity Year which the Preliminary RCM Constraint Equations or RCM Constraint Equation applies; and
- (d) the letter "S" followed by a number indicating relevant step of Appendix 3 of the WEM Rules, in which the Constraint Set first applies to for the relevant RCM Capacity Year.

**E[H] Example: Naming an RCM Constraint Equation**

The following shows an example of a Thermal RCM Constraint Equation that conforms with the Constraint Equation naming convention.

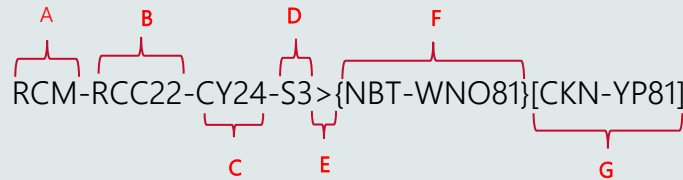

Where:

- A to D represent the components of the Constraint Equation Prefix Code under paragraph 4.1.1(a);
- E represents the Cause ID under paragraph 4.1.1(b);
- F represents the monitored element under paragraph 4.1.1(c); and
- G represents the contingent element under paragraph 4.1.1(d).

**E[I] Example: Naming an RCM Constraint Set**

The following shows an example of an RCM Constraint Set that conforms with the Constraint Set naming convention, where A to D represent the Constraint Set Prefix Code under paragraph 4.1.2.

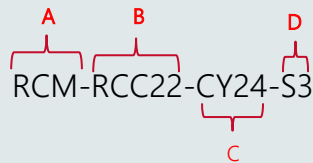

Where:

- A to D represent the components of the Constraint Equation Prefix Code under paragraph 4.1.2(a);

**E[J] Physical equipment identifier**

AEMO may also identify the physical equipment following the conventions described in this paragraph:

- All Network equipment identifiers are associated with a primary substation, as determined by the connection point busbar.
- Two-terminal elements also use a secondary busbar.
- Substations in the Western Power Network are designated by unique codes of one to three letters.
- The Network Operator distinguishes between distribution zone substations and (primarily) bulk-transmission terminal substations. Terminal substations have multiple entries for different voltage levels, as per the following examples:

- W: Wellington Street zone substation
- MR: Margaret River zone substation
- MU 132: 132 kV section of Muja terminal substation
- MU 330: 330 kV section of Muja terminal substation
- TST 330: Three Springs 330 kV terminal substation
- A shorthand code is used to indicate the nominal voltage of Network assets
  - 9: 330 kV
  - 8: 132 kV
  - 7: 66 kV
  - 6: 33 kV
  - 5: <22 kV
  - X: 220 kV

(Note that a Network Operator may further distinguish the distribution voltages by assigning 5: 22 kV, 3: 11 kV, 2: 6.6 kV).

- The following paragraphs describe the conventions for each of the following asset classes:
  - Transmission lines
  - Transformers
  - Other equipment (auxiliary equipment and reactive plant)

### **E[J1] Transmission lines**

Transmission lines use the format *S1-S2 VC*, where:

- S1, S2 are the codes for the primary and secondary busbar connected;
- V is a voltage code:
- C is the circuit ID (typically 1, 2 or 3)

Examples include:

- KW-ST 92: second 330 kV line connecting Kwinana and Southern terminal substations
- KDN-MRT X1: first 220 kV line connecting Kondinin and Merredin terminal substations

### **E[J2] Transformers**

Transformers use the format *SUB TX SIDE*, where:

- SUB: substation code.
- TX: transformer identifier (typically T1, T2 etc.).
- SIDE: optional designation to indicate high- or low-voltage side and/or winding (if relevant).

Generator step-up transformers omit the *SIDE* designation.

Examples include:

- MU BTT3 LV: Muja bus-tie transformer 3, as seen from the 220 kV side.
- MU BTT3 HV : Muja bus-tie transformer 3, as seen from the 330 kV side.
- MU SUT8 : Generator step up transformer 8 at Muja.

### E[J3] Other equipment

Other equipment follows the form SUB T VN, where:

- SUB is the substation code.
- T: type code that varies with asset type.
- V is a voltage code.
- N is the asset number (typically 1, 2. A. B etc.).

Common type codes are summarised in the following table:

Code	Asset	Example
CP	Capacitor	GLT CP 82: Guilford Terminal 132 kV capacitor 2.
RX	Reactor	MU RX 62A: Muja 33 kV shunt reactor A (connects to the 2 <sup>nd</sup> auxiliary winding of a bus-tie transformer). ST RX 8846: Southern Terminal 132 kV reactor in series with the 846 bus-coupler.
VC	Static VAR compensator	WKT SVC 61: West Kalgoorlie Terminal 30.5 kV SVC 1.

DRAFT

## 5. VERIFYING RCM CONSTRAINT EQUATIONS

- 5.1.1. To satisfy its requirements under clause 2.27A.10(b)(i)(2), AEMO may assess the formulation of one or more RCM Constraint Equations in accordance with paragraphs 5.1.2 and 5.1.5, to ensure that, in its reasonable opinion, they adequately define the capability of the Network at the time of Peak Demand and are appropriate for application in the Network Access Quantity Model.
- 5.1.2. When assessing the formulation of a Thermal RCM Constraint Equation, AEMO may:
- (a) prepare several Facility Dispatch Scenarios, each of which result in the LHS and RHS of the Constraint Equation having equal values. This indicates that the power system is operating at the limit defined by the Thermal RCM Constraint Equation;
  - (b) use the power system models prepared under paragraph 2.1.3, and for each Facility Dispatch Scenario prepared under paragraph 5.1.2(a), calculate the power transfer on the relevant monitored element being protected by Thermal RCM Constraint Equation when the contingent element is removed from service; and
  - (c) compare the power transfer on the monitored element (in MVA) with its rating (in MVA) and:
    - (i) if the difference is within or equal to the error tolerance for all considered Facility Dispatch Scenarios under paragraph 5.1.2(a), the Thermal RCM Constraint Equation is considered acceptable; or
    - (ii) if the difference is outside the error tolerance for one or more of the Facility Dispatch Scenarios under paragraph 5.1.2(a), an alternative formulation may be required for the Thermal RCM Constraint Equation.
- 5.1.3. AEMO may determine (having regard to relevant matters, including those specified in paragraphs 5.1.1 and 5.1.2) that a Thermal RCM Constraint Equation is not appropriate and that an alternative formulation is required.
- 5.1.4. AEMO may determine an alternative formulation by deviating from the processes specified under paragraphs 2.2 and 2.3, applying one or more of the following:
- (a) using a different Operating Margin;
  - (b) applying an additional static constant values to the RHS of the RCM Constraint Equation;
  - (c) adding additional logic to the RHS of the RCM Constraint Equation so that a dynamic constant value is calculated dependent on the status of one or more Facilities in a particular Facility Dispatch Scenario;
  - (d) applying different assumptions to the model of the power system prepared under paragraph 2.2.2 to calculate alternative Sensitivity Factors for one or more Facilities; or
  - (e) using multiple RCM Constraint Equations to control power transfer on the monitored element, but with only one version invoked at any one time, based on the actual Facility Dispatch Scenario under consideration.

**E[K] Adjusting a Thermal RCM Constraint Equation**

Examples of circumstances where AEMO may apply paragraph 5.1.3 include, but are not limited to:

- (a) the assumed Power Factor of 0.95 on the monitored element is not representative and a different Operating Margin is required;
- (b) the Sensitivity Factor for SWIS Demand term, or the constant values under paragraphs 2.2.4 may be fine-tuned by adjusting the voltage profiles in one or more parts of the Network (by applying different sets of assumptions to transformer tap positions, status of reactive power device, reactive power output of an RCM Facility, etc.), to the extent that the voltage profiles are still reasonably representative of the Network operating condition at Peak Demand;
- (c) AEMO may determine that the formulation of a Constraint Equation may be materially different under certain Facility Dispatch Scenarios, thereby requiring multiple versions of the Thermal RCM Constraint Equation, with only one version invoked at any one time.

5.1.5. When assessing the formulation of a Non-Thermal RCM Constraint Equation, AEMO may:

- (a) prepare several Facility Dispatch Scenarios, each of which result in the LHS and RHS of the Constraint Equation having equal values. This indicates that the power system is operating at the Non-Thermal Network Limits defined by the Non-Thermal RCM Constraint Equation;
- (b) with the aid of the Non-Thermal Limit Advice provided by the relevant Network Operator, determine the non-thermal power transfer limit for each Facility Dispatch Scenario under paragraph 5.1.5(a);
- (c) use the power system models prepared under paragraph 2.1.3, and for each Facility Dispatch Scenario prepared under paragraph 5.1.5(a), calculate the power transfer on the relevant monitored element being protected by the Non-Thermal RCM Constraint Equation when the contingent element is removed from service;
- (d) compare the power transfer on the monitored element calculated at paragraph 5.1.5(c) with the non-thermal power transfer limit calculated at paragraph 5.1.5(b) and:
  - (i) if the difference is within or equal to the error tolerance, for all considered Facility Dispatch Scenarios under paragraph 5.1.5(a), the Non-Thermal RCM Constraint Equation is considered acceptable; and
  - (ii) if the difference is outside the error tolerance, for one or more of the Facility Dispatch Scenarios under paragraph 5.1.5(a), an alternative formulation may be required for the Non-Thermal RCM Constraint Equation.

5.1.6. AEMO may determine (having regard to relevant matters, including those specified in paragraphs 5.1.5(d)(ii)) that a Non-Thermal RCM Constraint Equation is not appropriate and that an alternative formulation is required.

5.1.7. AEMO may determine an alternative Non-Thermal RCM Constraint Equation formulation by :

- (a) applying one or more options in paragraph 5.1.3;
- (b) applying a different coefficient under paragraphs 2.4.2(a); or
- (c) applying the approach in paragraph 2.4.2(b).

### **E[L] Power system model improvements**

AEMO verifies its power system models against historical SCADA network conditions and continuously improve their accuracy in representing the power system. These continuous refinements include but are not limited to, updating the models with:

- (a) up-to-date Network information, as they become available from a Network Operator;
- (b) new Facility models or updated existing Facility models, as they become available from a Network Operator;
- (c) models of Network components that have yet been represented, but are deemed to have increasing and material impact on the study outcome; or
- (d) more accurate models where inaccuracies have been identified.

AEMO's the verification process in paragraph 5 may also identify a need for further refinement of the power system models.

The continuous refinement may result in changes to the RCM Constraint Equations periodically.

DRAFT

## APPENDIX A. RELEVANT RULE CLAUSES

Table 4 details:

- (e) the head of power clauses in the WEM Rules under which the Procedure has been developed; and
- (f) each clause in the WEM Rules requiring an obligation, process or requirement be documented in a WEM Procedure, where the obligation, process or requirement has been documented in this Procedure.

**Table 4 Relevant clauses of the WEM Rules**

Clause
2.27A.10(b)
2.27A.10(b)(i)(1)
2.27A.10(b)(i)(2)
2.27A.10(b)(ii)
2.27A.10(c)
2.27A.10(cA)
2.27A.10(cB)
2.27A.10(d)