

Appendix I – Construction Management Plan

**VICTORIA PARK TO CANNING
LEVEL CROSSING REMOVAL PROGRAM
PTA 200140**

**CONSTRUCTION
MANAGEMENT PLAN**

PTA NUMBER: LXR-ALUA-CM-PLN-00001

ALUA NUMBER: LXR-CON-GN-PM-MG-PLN-00001



ARMADALE LINE UPGRADE ALLIANCE

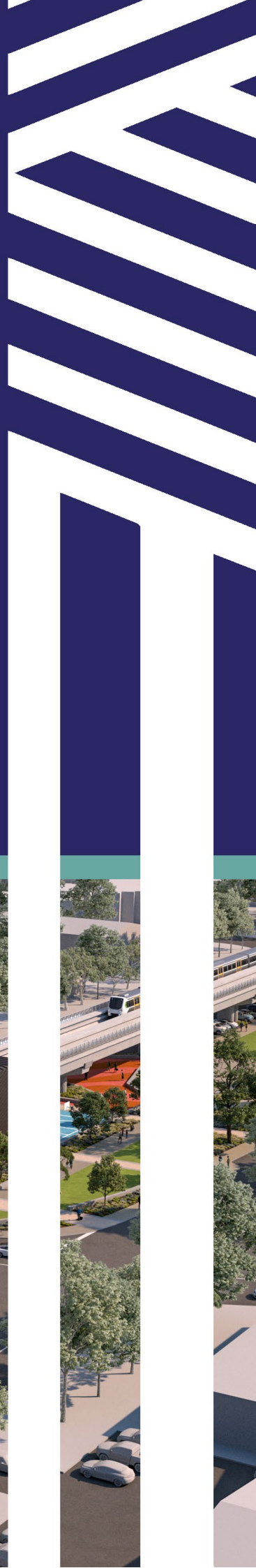

Document Control Record

Document Prepared by:

Armada Line Upgrade Alliance (ALUA)

Level 1, 3 Craig Street, Burswood

Western Australia 6100

E enquires@alualliance.com.au

Document Control						
Report Title	LXR-ALUA-CM-PLN-00001					
Client	OMTID					
Rev	Date	Revision Details / Status	Author	Reviewer	Approver	SEM
A	03/05/2022	Issued for review	Jeff Tyloo	Jeff Tyloo		
B	12/08/2022	Issued for review	Emma Tsakalos	Jeff Tyloo		
B2	6/10/2022	Issued for DA 1	Ben Johnston	Jeff Tyloo		
Current Revision	Rev B					

Table of Contents

1.	Introduction	8
1.1	Purpose.....	8
1.2	Victoria Park to Canning Level Crossing Removal Program.....	8
1.3	Armada Line Upgrade Alliance	8
1.4	Alignment with Other Project Plans	9
1.5	Plan Development, Control and Amendment	9
2.	Organisational Structure	11
2.1	Roles and Responsibilities.....	11
3.	Project Conditions, Accommodation and Facilities	13
3.1	Alliance Offices	13
3.2	Site Amenities	13
3.3	General Lighting	14
4.	Construction Operations	15
4.1	Working Hours	15
4.2	Maintenance During Construction	15
4.3	Blasting	15
4.4	Construction Constraints	15
4.5	Removal of Disused Features	16
4.6	Temporary Fencing and Hoardings	16
4.7	Cleanliness of the Construction Site.....	16
4.8	Fire Precautions.....	17
4.9	Temporary Works	18
4.10	Quality of Materials and Workmanship.....	18
4.11	Site Re-instatement	18
4.12	Monitoring during the Non-Conformance Correction Period	19
4.13	Maintenance by Others during Non-conformance Correction Period.....	19
4.14	Reticulation and Bores, Drainage and Garden Fixtures.....	19
4.15	Public Amenities	19
4.16	Dilapidation Surveys and Condition Reports	19
5.	Health and Safety	20
5.1	Work Methods and Training.....	20
5.2	Safe Work Method Statements.....	20
5.3	Rail Safety.....	20
5.4	Railway Safeworking	21
5.5	Emergency Management.....	24
5.6	Safety Risk Management.....	24
5.7	COVID-19	24
5.8	Incident Management	24
6.	Risk Management	25

6.1	Planning	25
6.2	Work Pack.....	25
7.	Environment	26
7.1	Discharge Water Quality	26
7.2	Construction Noise and Vibration	26
7.3	Noise	26
7.4	Vibration.....	28
7.5	Heritage Management	30
7.6	Out of Hours Works	30
7.7	Out of Hours Public Notification.....	31
7.8	Construction Water	31
7.9	Site Reinstatement	31
7.10	Storage of Materials.....	32
7.11	Existing Ground	32
8.	Quality Assurance	34
9.	Survey.....	37
9.1	Coordinates and Datum.....	38
9.2	Personnel.....	38
9.3	Existing Survey and Mapping Data	38
9.4	Protection of Survey Control.....	38
10.	Resources.....	39
10.1	Labour	39
10.2	Plant and Equipment	39
10.3	Subcontractors.....	42
10.4	Key Resources	43
11.	Community Engagement	44
11.1	Stakeholder and Community Management	44
12.	Interface Management.....	46
12.1	Disruption to Perth’s Public Transport Network.....	46
12.2	Adjacent Property Access.....	47
12.3	Advertising and Site Signs.....	47
12.4	Impact to Bus Network.....	47
13.	Services	55
13.1	General	55
13.2	Owners of Utilities and Services in the Rail Corridor.....	55
13.3	Avoiding and Protecting Utilities and Services	56
13.4	Effective Management of Service and Utility Relocations	61
13.5	Summary of Services and Utilities	61
14.	Logistics	66
14.1	Traffic Management.....	66

14.2 Site layout 67

14.3 Heavy haulage routes 68

14.4 Site vehicle access 74

14.5 Walkways 76

14.6 Lighting plans 77

14.7 Laydown area 77

15. Staging 80

15.1 Project Approach 80

15.2 Road and Traffic Phasing (Not applicable will be covered under separate DA) 83

16. Construction Methodology 84

16.1 Overview 84

16.2 Statutory approvals 85

16.3 Design interface 85

16.4 Civil and Services 85

16.5 Structures 94

16.6 Stations Demolition 123

16.7 Rail Systems 128

Appendix A – Indicative Intersection Phasing 149

Appendix B – Traffic Management Plan including Heavy Haulage Strategy 150

Abbreviations and Acronyms

Term	Definition
AD	Alliance Development
ADT	Alliance Development Team
AEPP	Aboriginal Engagement and Participation Plan
ALT	Alliance Leadership Team
AMP	Alliance Management Plan
AMT	Alliance Management Team
APT	Alliance Project Team
BIM	Building Information Modelling
CBS	Cost Breakdown Structure
CCM	Configuration Change Manager
CCR	Configuration Change Register
CEMP	Construction Environmental Management Plan
CEMS	Construction Environment Management System
CEP	Community Engagement Plan
CI	Configuration Item
DCN	Design Change Notice
DOA	Delegation of Authority
HR	Human Resources
HSEQ	Health, Safety, Environment and Quality
IDC	Interdisciplinary Check
IDR	Interdisciplinary Review
IFC	Issued for Construction
IMS	Integrated Management System
IR	Industrial Relations
ISO	International Organization for Standardization
IT	Information Technology
KRA	Key Result Area
KPI	Key Performance Indicator
MCOS	Minimum Conditions of Satisfaction
NOP	Non-Owner Participant
O&M	Operations and Maintenance
OMTID	The Office of Major Transport Infrastructure Delivery
ONRSR	Office of the National Rail Safety Regulator
OP	Owner Participant (Principal)
PAA	Project Alliance Agreement
PTA	Public Transport Authority

Term	Definition
R&O	Risk and Opportunity
RAMS	Reliability, Availability, Maintainability and Safety
RFI	Request for Information
SFAIRP	So far as is reasonably practicable
SiD	Safety in Design
SIMP	Stakeholder Interface Management Plan
SSAMP	Systems Safety Assurance Management Plan
SWTC	Scope of Work and Technical Criteria
TOC	Total Outturn Cost
VFM	Value for Money
WAIPS	Western Australian Industry Participation Strategy
WBS	Work Breakdown Structure

1. Introduction

1.1 Purpose

The Construction Management Plan (CMP) describes how ALUA will satisfy all the relevant requirements of the PAA and the SWTC relevant to the works associated with Development Approval Application 1 Early works and Viaduct works. The CMP describes the construction methodology and sequencing for implementation of the Works and provides plant and equipment details proposed for use for each stage of construction and how construction interfaces will be managed for these Works.

1.2 Victoria Park to Canning Level Crossing Removal Program

The Victoria Park to Canning Level Crossing Removal (LXR) Program design and construction project (Project) will involve all design and construction of the LXR works including commissioning, interconnection with the existing passenger rail line network and Final Asset Acceptance of those works.

The Project involves the removal of level crossings on the inner section of the Armadale line, which has been identified as the priority across the Perth metropolitan passenger rail network. The level crossings proposed for removal have been categorised into two packages:

- The Oats Street package of works being:
 - Removal of the Mint Street/Archer Street, Oats Street and Welshpool Road level crossings
 - Elevation of the Carlisle and Oats Street stations
 - Future proofing of Welshpool Station.
- Wharf Street package of works being:
 - Removal of the Wharf Street and Hamilton Street level crossings
 - Elevation of the Queens Park and Cannington stations
 - Construction of a new double-ended centre line turnback between Cannington Station and William Street.

In addition to the main packages of work, there are additional enabling works that make up the overall scope of the project, and include the following:

- Temporary MCR
- Service relocations
- Site Establishment
- Temporary bus interchanges

1.3 Armadale Line Upgrade Alliance

The Armadale Line Upgrade Alliance, as shown in Figure 1, comprises the:

- Owner Participant the Public Transport Authority
- Constructor Non-Owner Participants (Alliances) Acciona and BMD

- Designer NOPs WSP and AECOM.

The NOPs will be supported by specialist partners and consultants.

1.4 Alignment with Other Project Plans

The Alliance Management Plan (AMP) includes all the management plans as nominated in the SWTC for the project and as shown in

Figure 2 below. The AMP is the overarching management plan for the Project. The AMP and all other supporting plans, including this Construction Management Plan, are interactive and provide support to the AMP.



FIGURE 1: ALLIANCE MANAGEMENT PLAN SUITE

1.5 Plan Development, Control and Amendment

A single document owner, the Operations Manager, will manage the Construction Management Plan. The Plan, any revisions or amendments to it, and any subsidiary procedures, tools and templates referenced within it, are to be reviewed and subject to approval by the document owner and the Alliance Manager.

This Plan supports the delivery of the Project works throughout the Project duration. The overarching Alliance Management Plan was developed in advance of the PAA. All 20 other Project Plans and associated sub-plans will be finalised and approved in accordance with clause 11.5 of the Preferred Project Alliance Agreement

(PAA). The Alliance Participants will be responsible for implementing this Plan and its related Project Plans. The Plans will be updated and revised whenever it is necessary to do so or when directed by the Alliance Leadership Team (ALT) or the PTA. All updated and revised plans will be immediately provided to the ALT and the PTA, as applicable, for consideration and approval.

The Alliance Management Plan and the other Project Plans must not be amended without the prior written approval of the ALT and the AMT respectively.

2. Organisational Structure

The Alliance has developed the following governance structure, resulting in a Construction Manager supporting the Operations Manager and responsible for the construction delivery of Civil, Services, Structures, Station Building and Rail Infrastructure. The Construction Manager is a member of the Alliance Delivery Team, reporting directly to the Operations Manager.

The governance structure for Construction is shown below in Figure 3 as it sits underneath the Construction Manager. A detailed Organisation Chart detailing how the Construction Team relates to the wider project team is located in the Alliance Management Plan (LXR-ALUA-PM-PLN-00001).

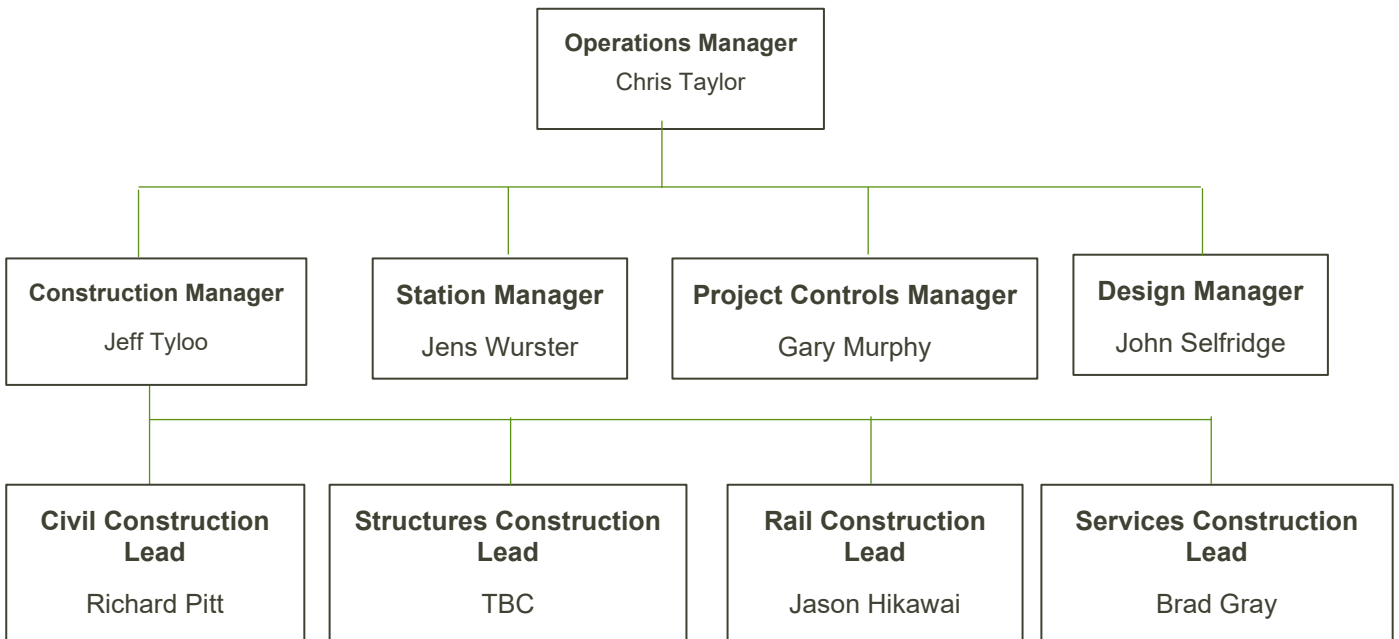

FIGURE 2 GOVERNANCE STRUCTURE

The Alliance will employ Construction Engineers and Supervisors that are skilled in the construction techniques that will be used in the work. This includes the necessity to be able to control and manage all Works that are subcontracted to specialist organisations.

2.1 Roles and Responsibilities

Management responsibilities for the construction roles are detailed in position descriptions and the Delegation of Authority Matrix. Key construction management responsibilities include achieving safety, cost, program, quality, environmental/sustainability, traffic and pedestrian management, interface coordination, stakeholder and community management, rail planning and access, commissioning, and completion performance objectives. Key Construction Team Roles and Responsibilities are outlined in Table 1.

TABLE 1: ROLES AND RESPONSIBILITIES

Role	Responsibility
Construction Manager	Oversee construction of the project in accordance with the Alliance Charter We Work, Project Objectives and project requirements. Lead, direct and coordinate the operation of the entire construction team.

Role	Responsibility
Package Manager	To plan, manage and provide direction across the project to effectively coordinate the design interface with construction, procurement, fabrication of all construction activities for their respective packages – note Package Managers will lead and coordinate a number of discipline leads for delivery of packages.
Discipline Lead (SRE/PE Construction)	The Discipline Lead for Construction will undertake the roles of Suppliers Responsible Engineer (Construction) and Project Engineer (Construction) for their respective discipline. They will coordinate with other Discipline Leads in support of package delivery. They will interface with their Design SRE/PE counterparts.
Senior Project Engineer	Plan, manage and coordinate within a specific area or discipline to effectively coordinate the design, procurement, and construction elements of an area/work activities. Develop relevant construction methodologies including verification of changes to construction methods and coordination of the Works including programming, plant, equipment, labour, materials and subcontractor management (as applicable).
Project Engineer	Plan, manage and coordinate on-site engineering support to assist in the delivery of the work activities. Ensure that works are being performed in accordance with work packs including to quality requirements.
Site Engineer (Graduate and Undergraduate)	Provide on-site engineering support to assist in the delivery of the work activities. Ensure that works are being performed in accordance with work pack
General Superintendent	Plan, manage and coordinate the availability, allocation, and efficient utilisation of resources (plant, labour, and materials) onsite. Ensure that works are being performed in accordance with work pack.
Supervisor	Coordinate all day-to-day activities in a specific area or in a specific discipline through management of leading hands, direct report site employees, plant resources and subcontractor teams.
Stakeholder and Community Engagement Manager	Engage, collaborate and coordinate with stakeholders, including the local community. Manage, investigate and address complaints (Refer Section 8.7.1).

Further definition of Responsibilities for team members are detailed in the area specific management plan.

3. Project Conditions, Accommodation and Facilities

3.1 Alliance Offices

The Alliance head office will be based in Level 1, 3 Craig Street Burswood 6100, approx.4.1 km drive from Carlisle Station. This will function as the project head office and will be occupied primarily by the designers during design period along with project support personnel such as planning, project controls, procurement, human resource, and accounts administration teams. Office allocations shall be available to OMTID within the Alliance Office to ensure an integrated and fully functioning team is formed. This Office has the capacity to occupy 120 staff along with 50 parking bays. It will be in use for the duration of the Project.



FIGURE 3 LOCATION OF 3 CRAIG STREET, THE ALLIANCE OFFICE

3.2 Site Amenities

ALUA will use a combination of temporary site facilities and off-site commercial properties close to the construction zones. This selection criteria have been shaped by the following items

- Use of commercial property to provide Workforce Parking and ensure that Public Parking is maximized.
- Limited space onsite for temporary site facilities
- An intention to reduce travel time for workers commuting from front work to crib facilities

OUR VALUES: MORAL COURAGE | RAISING THE BAR | PEOPLE AND FAMILY

- Establishing Temporary Facilities adjacent to utility connections, and
- Capacity of Crib and Ablution basing on manning numbers in accordance with Work Safe Code of Practice requirements.

Car parking in Leased Commercial Facilities will be used by construction personnel which will reduce the use of local communal car parks. Access to services, water, power, sewer and telecommunication was considered and assessed. Permanent service connections will be established to improve efficiency wherever possible. The indicative locations and number of site amenities for each construction zone, along with peak manning is tabulated below. The exact locations are still being optimised with further input from the detailed design required to finalise the location to ensure these facilities are outside of the construction footprint.

Package 1					
Z1 - Carlisle		Z2 - Oats		Z2- Welshpool	
Station	Civ-Str-Tra	Station	Civ-Str-Tra	Civ-Str-Tra	
1 x 12x3 Office	1 x 12x3 Office	Comm Office	Comm Office	Comm Office	
2 x 12x3 Crib	2 x 12x3 Crib	1 x Crib	1 x Crib	1 x Crib	
2 x 12x3 Ablution	2 x 12x3 Ablution	1 x Ablution	1 x Ablution	1 x Ablution	
		2 x 12x3 Crib	2 x 12x3 Crib	1 x 12x3 Crib	
		2 x 12x3 Ablution	2 x 12x3 Ablution	1 x 12x3 Ablution	

Package 2			
Z3 - Queens		Z3 - Cannington	
Station	Civ-Str-Tra	Station	Civ-Str-Tra
Comm Office	Comm Office	Comm Office	Comm Office
1 x Crib	1 x Crib	2 x Crib	2 x Crib
1 x Ablution	1 x Ablution	2 x Ablution	2 x Ablution
2 x 12x3 Crib	2 x 12x3 Crib	2 x 12x3 Crib	2 x 12x3 Crib
2 x 12x3 Ablution	2 x 12x3 Ablution	2 x 12x3 Ablution	2 x 12x3 Ablution

Commercial Property
Hire of Temporary Facilities

FIGURE 4: SUMMARY OF SITE FACILITIES –POTENTIAL COMMERCIAL PROPERTIES AND TEMPORARY FACILITIES

3.3 General Lighting

Lighting in the general work areas will be of a level to enable work to be carried out safely.

Emergency lighting will be provided important to assist workers to exit the workplace office in an emergency.

Internally illuminated emergency evacuation signage may be used as part of an existing emergency lighting system. The system of lighting will have battery backup light fittings capable of illuminating the exit signage and provide clear directions for safe exit from the workplace in the event of power failure.

4. Construction Operations

4.1 Working Hours

The Alliance will ensure, except as required by law, the maximum working hours permitted to be between 7.00 am and 7.00 pm, Monday to Saturday. Work outside these hours may be permitted for specific operations subject to the approval of the PTA's Representative and compliance with the noise limits. Work may be allowed on public holidays if permitted by law and then only with the prior approval of the PTA's Representative.

The Alliance will ensure individual works hours comply with fatigue management requirements in accordance with relevant OHS regulations, Codes of Practice, and PTA Doc No. 7110-000-003 Safety Management Systems Contractor Standard.

The Alliance will obtain the approval of the PTA's Representative for the start and finish times and Business Days prior to commencement of work on a Construction Site. All other Works outside of the nominated and approved times will not be executed without the express approval of the PTA's Representative.

In addition to obtaining approval from the PTA's Representative, the Alliance will notify, where required, the relevant Local Government Agency, DWER and/or local residents as per the Alliance's Stakeholder Interface Management Plan. These notifications will be in accordance with the individual required timelines depending on the level of impact of the works, the hours the works will be carried out in and local government requirements.

In all cases for working outside the normal working hours by law, the Alliance will promptly notify the PTA's Representative in writing of the circumstances in which the Alliance requests such approval and provide evidence of relevant local Government Agency and /or DWER approval, including the provisions of regulation 13 of the Environmental Protection (Noise) Regulations 1997.

4.2 Maintenance During Construction

During the Works, the Alliance will maintain and repair the following areas:

- The Construction Site areas, and
- The local areas from the commencement of any construction activities within each local area until the Handover of that local area to the relevant Government Agency.

All PTA operational Assets will be freely accessible for uninterrupted day-to-day maintenance activities.

The Alliance will ensure that all infrastructure, facilities and amenities in the areas being maintained are at all times fit-for-purpose, clean and tidy, free from graffiti and in a condition that satisfies the requirements of the PAA and SWTC.

The extended storage of rubbish or loose items on the Construction Site, local areas or elsewhere is not permitted.

4.3 Blasting

Blasting will not be used for any Works.

4.4 Construction Constraints

The Alliance will act to minimise the impact of the Works on nearby developments and the community. These includes as a minimum:

The Alliance will ensure zero unplanned disruption to the normal operation of the metropolitan rail network, including the access and egress to/from stations.

Existing PShPs and footpaths will be maintained throughout construction. Temporary shared paths will have a bituminous or smooth concrete surface at least 2.0m wide with no loose material and have at least 0.3m clearance to any obstacles including fences. Temporary bus stops & bus interchanges and temporary carparks will have a bituminous surface. Temporary lighting will be provided where lighting is diminished by the Alliance's work. Any temporary fences or screens beside shared paths will be adequately restrained against overturning and deflection from wind.

A height clearance of no less than 5.3m will be maintained on all roads open to traffic unless effective advance warning devices are provided in accordance with MRWA and LGA requirements.

Security of all adjacent properties affected by all Works will be always maintained to a standard equivalent to that which currently exists.

Vehicles associated with the Project Activities will not park in public bays or Transperth car parks available to the public. Access to the Site by public transport is strongly encouraged.

All parked Alliance vehicles are to be contained within, and provided with parking within, the fenced area of the site.

The Alliance will plan road works and closures with consideration of impacts to the local community, minimising disruption where possible through considerations such as closures at night when traffic volumes are low.

4.5 Removal of Disused Features

Disused or abandoned pipes, cables, conduits or structures encountered while carrying out Works within the Construction Site (above surface or sub-surface) will be removed and trenches backfilled or filled with stabilised sand.

4.6 Temporary Fencing and Hoardings

Temporary fencing and hoardings will be provided and maintained as necessary to provide an aesthetically pleasing appearance, control public access to parts of the Construction Site and maintain safety and security.

The temporary fencing and hoarding will be of a standard which is suitable to address the issues of public safety, road and rail safety, security, noise and visual impact arising from the work.

The temporary fencing and hoarding will be designed for stability against wind loading and will not obstruct the Signalling line of sight for railway operations.

The Alliance will provide temporary hoarding at all Construction Sites adjacent to roads or other public access areas to provide an aesthetically pleasing appearance for passing motorists and pedestrians.

Any temporary artworks will be consistent with the Project branding, provide wayfinding, and will be approved by the PTA's Representative.

Temporary fencing and hoardings will comply to all relevant PTA standards and Codes of Practice, including the Earthing and Bonding Specification.

4.7 Cleanliness of the Construction Site

The Construction Site, including the exterior of all perimeter fences/hoardings will be maintained in a clean and tidy manner throughout the Works. Rubbish or loose items will not be stored on the Construction Site. Use of the Construction Site will meet the environmental sensitivity requirements of the SWTC. The Alliance will

take measures to prevent littering of the Construction Site by its Personnel. In addition, the Alliance will clean up any rubbish and dirt generated by the Works in the surrounding area.

Temporary site facilities requirements are as follows:

- Site sheds will be maintained in excellent condition
- Site sheds will be established at locations and positions that minimise the impact on adjoining properties and residents, and
- All facilities utilised for the purpose of the Works will be sited, constructed, and maintained to meet the requirements of the PTA and relevant Government Agencies.

The Alliance will provide site facilities for use by the PTA. Temporary site facilities will satisfy the sustainability requirements of this SWTC. All temporary site facilities, including site sheds, will be maintained free of graffiti and any advertising material.

The Alliance will carry out daily inspections of all temporary site facilities including site sheds.

Suitable temporary toilets and shower facilities will be provided. Temporary facilities will be connected to the main sewer system wherever practical and maintained in a clean, tidy and hygienic state and shielded from public view.

Any graffiti within the Construction Site, including outward facing surfaces of any hoardings and the like surrounding the Construction Site, will be covered or removed by the Alliance within 24 hours, subject to operational constraints. Offensive graffiti is to be removed within the shorter timeframe of two hours, in accordance with the PTA's and Government's graffiti removal policy.

The Alliance will, prior to Practical Completion, clear away and remove from the Construction Site all plant, surplus material, rubbish and Temporary Works of every kind and fill, consolidate and level off all excavations made by the Alliance on the Construction Site.

In addition, prior to Practical Completion, the Alliance will clean and wash all sumps and internal rooms clear of any fine dusts to prevent false alarms due to dust in smoke detectors within the confined areas.

4.8 Fire Precautions

The Alliance will, during the Works, do all things necessary to minimise the risk of fire within the Construction Site and minimise the risk of fire adjacent to the Construction Site due to the performance of the work.

During the Works, the Alliance will maintain and repair the following areas:

- The Construction Site areas, and
- The local areas from the commencement of any construction activities within each local area until the Handover of that local area to the relevant Government Agency.

All PTA operational Assets will be freely accessible for uninterrupted day-to-day maintenance activities.

The Alliance will ensure that all infrastructure, facilities and amenities in the areas being maintained are at all times fit-for-purpose, clean and tidy, free from graffiti and in a condition that satisfies the requirements of the PAA and SWTC.

The extended storage of rubbish or loose items on the Construction Site, local areas or elsewhere is not permitted.

4.9 Temporary Works

As part of the method of construction, the Alliance will identify and describe all Temporary Works requirements, including provision of a Temporary Works register.

The Alliance will provide a description of the method of construction for each element of the Temporary Works.

The Alliance will inspect and maintain all Temporary Works each shift to ensure adequacy and safety in accordance with the temporary works designer requirements.

The Alliance will design, provide, maintain and remove on completion all Temporary Works as may be necessary for the execution of the Works.

All lifting and piling activities undertaken by tracked plant will be carried out from working platforms designed and constructed to a standard not less than the standards provided in: BR470 Working Platforms for Tracked Plant.

All lifting activities will be undertaken in accordance with: AS 4991 Lifting Devices, AS 3775 Chain Slings for Lifting Purposes, and AS 2549 Cranes (Including Hoists and Winches) Glossary of Terms.

The Alliance's Temporary Works designs will be verified by the civil/structural and/or geotechnical and hydrogeological Design Verifiers as appropriate as part of the design process and submitted to the PTA's Representative for review and comment as part of that Design Package.

Filling of voids resulting from the extraction of Temporary Works will be carried out simultaneously with the extraction. The method of extraction or removal will be such that there is no risk of damage to the Works or existing Assets.

Before removing any strut or anchor the Alliance will ensure that there is sufficient support to the retained ground to avoid failure or excessive movement.

4.10 Quality of Materials and Workmanship

All workmanship and materials employed by the Alliance in carrying out the Works will comply with this SWTC, and PTA Doc No. 7610-000-010 Quality Management - Contractor Standard.

As a minimum, construction tolerances, surface requirements and finishes will meet PTA and industry standards, as specified in the PTA's and MRWA's specifications, Codes and Best Practices, unless specified elsewhere in the SWTC.

Assets will be fitted in a manner to meet OS&H, human factor standards, aesthetics, and maintainability requirements.

4.11 Site Re-instatement

The Alliance will reinstate the Construction Site and complete the architectural and landscaping work forming part of the Works progressively as each part of the work is completed.

All parts of the Construction Site used for Temporary Works only and other land occupied or used by the Alliance for the purpose of the Works, including storage and site facilities, will be reinstated to a condition at least equivalent to that existing prior to the occupation or use unless otherwise stated in this SWTC.

Site reinstatement will be undertaken in accordance with this SWTC. To adequately facilitate the reinstatement, pre- and post-construction dilapidation surveys will be carried for properties and public realms as specified by the STWC.

4.12 Monitoring during the Non-Conformance Correction Period

The Alliance will carry out all necessary monitoring during the Non-conformance Correction Period as specified in the PAA and SWTC.

The settlement monitoring points installed in accordance with the SWTC will be monitored and assessed with a minimum measurement frequency of monthly during construction and the Non-conformance Correction Period and reported every three months. Reports will include interpretation, identification of issues, comparison in graphical and tabular formats with all previous surveys including initial measurements, any recommendations for further action, monitoring or investigation arising from the survey; and

Record of any other monitoring or Testing will be undertaken.

4.13 Maintenance by Others during Non-conformance Correction Period

After the Date of Practical Completion, the PTA, Alliance's, Subcontractors or agents, along with the Alliance, will maintain the Works. Maintenance by or on behalf of the PTA or any other person does not relieve the Alliance from its obligations under the PAA and SWTC including regarding Non-conformance correction.

4.14 Reticulation and Bores, Drainage and Garden Fixtures

Any modification of reticulation, bores, drainage, and garden fixtures will be of the equivalent standard to that existing prior to the commencement of the Works.

4.15 Public Amenities

The Alliance will relocate/reinstate all public amenities affected by the Works, for example bus shelters, rubbish bins, etc. The location and standard of the reinstated amenities will be approved by the relevant Government Agencies.

4.16 Dilapidation Surveys and Condition Reports

To facilitate adequate reinstatement of the Construction Site and to monitor any potential impacts of the Works on the community, the Alliance will engage a contractor to perform pre-construction and post-construction surveys of properties and structures within 100m of the Works.

The contractor will be suitably qualified and have experience with other large Perth metropolitan projects.

Pre-construction surveys will be offered to all property owners via registered post, with inspections being managed through an online booking service. Inspections will be undertaken both internally and externally to identify defects and assess the overall pre-existing condition of the property. Detailed property condition reports will be provided for each surveyed property including photographic record of any existing defects (cracks, leaks, spalling, ground settlement, deformation, etc.). Pre-construction surveys will also be undertaken for all bridge structures, side roads, PSPs, pedestrian paths and road furniture.

Post-construction surveys will be completed for bridge structures and as required for all other properties and infrastructure. Property owners/tenants will have the ability to request post-construction surveys through the online portal. Where possible, the same inspector shall undertake any required post-construction inspections, following the same sequence and process as the pre-construction report.

The Alliance will also undertake condition surveys of carparks, stations and laydown areas prior to any works commencing.

5. Health and Safety

The Alliance Safety Management Plan (LXR-ALUA-SA-PLN-00001) (SMP) will be the guiding document for health and safety for completing works on the project. The SMP is the rail safety management plan and work health safety management plan. The SMP details the processes for management of risks specific to health and safety and review of risks during different phases of the project including mobilisation, construction, commissioning, and handover.

5.1 Work Methods and Training

The work methods used by the Alliance in carrying out the Works will result in the use and application of materials and workmanship which, as a minimum, comply with all applicable State, National and International Regulations, Codes, Standards, Guidelines and manufacturers recommendations and requirements, including PTA's general specifications and with the general standards and guidelines.

The Alliance will provide all Personnel involved in the Works with appropriate Training in the construction techniques and work methods to be applied to the Works.

5.2 Safe Work Method Statements

Safe Work Method Statements (SWMS), suitable for the tasks, will be developed by the responsible engineer/manager in consultation with the work crew undertaking the planned activities and will be included in the work pack for the task as outlined in the SMP. SWMS will be developed for any high-risk construction activities as deemed by the engineers and managers. At a minimum, the tasks listed in the OSH Regulations will be addressed.

The SWMS will:

- Identify the work that is high risk construction work
- Specify hazards relating to the high-risk construction work and the risks to health and safety
- Identify the risks to damage of equipment and permanent works associated with the high risk construction work
- Detail the qualifications and training required to complete the task
- Detail equipment used to the complete the task
- Describe the measures to be implemented to control the risks, and
- Describe how the control measures are to be implemented, monitored, and reviewed.

The SWMS will be short and focused on describing the specific hazards identified for the high-risk construction work to be undertaken and the control measures to be implemented so the work is carried out safely.

The SWMS will be easily understood by workers, including those from non-English speaking backgrounds. All workers involved in the task will read, understand, and sign their acceptance onto the SWMS.

SWMS will be available for information by anybody as requested and will remain with the work whilst works covered by the SWMS are being undertaken.

5.3 Rail Safety

The works will be performed under the auspices of the Rail Safety Accreditation of the PTA. ALUA's systems and processes will support the PTA's accreditation in this regard. The Rail Safety Manager is responsible for

administering the rail elements of the Safety Management Plan and monitoring for adherence to this plan for all of ALUA's activities.

5.4 Railway Safeworking

This section describes those actions undertaken to provide a safe workplace from the perspective of railway safeworking.

5.4.1 Rail Access

ALUA's Rail Corridor Access Plan is a key plan describing the requirements for rail safety management within the rail corridor. This plan contains relevant requirements of the following PTA plans in addition to addressing risks and opportunities, possession, resourcing and other relevant requirements.

- 9100-000-007 PTA Rail Safeworking Rules and Procedures
- 8110-400-029 Procedure Applying for Access to the PTA Operating Railway Corridor
- 8103-400-004 Procedure Working in and around the PTA Rail Corridor, Assets and Infrastructure
- 8110-100-016 Procedure Managing Risk in Shutdown Situation
- 8110-100-015 Procedure Logging on and Off the Rail Reserve
- 8110-400-030 Trenchless Excavations Beneath the PTA Operating Railway
- 8510-000-010 Procedure – Planning for OLE Permit to work, De-energisation & OLE Vicinity Form, and
- 8110-800-051 Working in the Train Control Area.

5.4.2 Planning for Safeworking within the Railway Corridor

- Personnel undertaking the work – numbers, skillsets, and other relevant factors.
- Equipment to be used – potential to encroach within the danger zone or obstruct the railway.
- Environmental factors – the topography, weather, time of day and other factors that may affect the proper provision of railway safeworking practices.
- Work processes to be employed and possible impacts to the infrastructure, properly informed by a competent subject matter expert.
- Organisational factors including the diversity of workgroup contained within a particular area.

The outcomes of the above planning will be incorporated into the Rail Safety Sub-Plans. Specific details on how the Alliance manage this risk during construction are covered further on in this plan.

The Alliance's Rail Corridor Access and Possession Plan (LXR-ALUA-RS-PLN-00001) addresses management of access to the key areas of work in detail.

5.4.3 Personnel Access to the Rail Corridor

Wherever possible, the strategy is to convert 'brownfield' areas into 'greenfield' areas using appropriate general exclusion fencing barriers. Regardless of any safeworking protection or delineation applications, as a minimum, all Project personnel requiring access to the active rail corridor must:

- Have completed the Project site induction
- Maintain a valid Rail Industry Worker Card

- Be medically fit (National Standard for Health Assessment of Rail Safety Workers)
- Present themselves fit for work and be free from the effects of drugs or alcohol
- Be wearing approved PPE (i.e. safety footwear, safety helmet, safety glasses and an orange high visibility vest/long sleeved shirt, and high visibility striped pants during hours of darkness).

Rail plant operators must hold the relevant training or licence to operate the rolling stock and be *Fit for all Duties* as per the requirements of the Category 1 medical. All requests to enter the rail corridor by Project personnel and visitors must be submitted to and approved by the assigned Safeworking Supervisor (Track Force Protection Coordinator or Protection Officer) on duty.

No one is permitted to enter the Rail Corridor until having first attended and endorsed both the construction pre-work brief and safeworking pre-start brief. Equally, no one is permitted to undertake any work activities until they have endorsed the relevant permit/s and SWMSs.

General exclusion fencing – permanent or semi-permanent fencing that creates a barrier between the worksite and the operational railway allowing workers to enter the area without a track access permit (TAP).

Delineation barrier – a temporary barrier that acts as a visual indicator. For the purposes of safeworking, this does not preclude workers from having a suitable TAP.

5.4.4 Rail Safety – Principles of Network Operations – Rule 1002

The Alliance will ensure that all works being carried out in the Danger Zone will, at all times, be protected in accordance with the PTA Safeworking Rules and Procedures.

Signatories to this SMP will ensure that:

- A safety assessment has been completed before persons enter the Danger Zone
- When in the Danger Zone, all workers must be protected
- Workers must have identified safe places when on track
- If rail traffic cannot be separated from workers, the rail traffic must be managed to ensure the safety of workers on track
- Work on track must only be carried out using a defined work on track method or authority
- The person who introduces the risk must ensure that the risk is appropriately managed
- Workers are to be provided with all applicable information and warned of hazards in the rail corridor.

To protect workers in the Danger Zone, the signatories shall ensure that one or more of the following safeworking rules are in place (as per Rule 1002).

For work that has the potential to obstruct the track or affect infrastructure integrity:

- Local Possession Authority (LPA) – Rule 3001
- Track Occupancy Authority (TOA) – Rule 3005.

For work that does NOT obstruct the track or affect infrastructure integrity:

- Absolute Signal Blocking (ASB) – Rule 3011
- Lookout Working – Rule 3013.

For work that does NOT have the potential to come within 3m of the nearest running line:

- Works Outside the Danger Zone – (WODZ).

The nominated Alliance Protection Officer will be responsible for setting up a safe system of work by applying one or more of the above authorities or methods and will issue rail safety relevant instructions to the work party.

5.4.5 Rail Safety – Unplanned Events

5.4.5.1 Reporting and Responding to a Condition Affecting the Network (CAN) – Rail Safety Emergency – Rule 2009

The Alliance will ensure that conditions that can or do affect the safety of operations of the network are reported immediately to:

- » Network Control Officer or Electrical Control Officer:

If not already protected, the Alliance will ensure the railway line is protected in accordance with the PTA Safeworking Rules and Procedures.

5.4.5.2 Notification of Damage to Infrastructure that does not Affect the Safety of Operations

If any infrastructure is damaged, the Alliance will ensure the damage is reported promptly to the PTA Representative for the works.

If any communication cable is damaged, the Communication Technician will be notified immediately.

5.4.6 Permission to Commence Work

Work of any nature within the closed, up and down mains can only commence after permission to start work has been received from the Protection Officer, all track protection has been applied and Train Control has approved that protection is in place. Prior to commencing work of any nature within the defined area permission will be obtained from the Urban Train Controller, in accordance with PTA Safeworking Rules and Procedures (9100-000-007).

5.4.7 On and Off Tracking Location

The Alliance will ensure, where there is a requirement throughout the Project to on- and off-track road–rail vehicles (RRVs,) a safeworking sub-plan will provide details about the on- and off-tracking location and safe working protection requirements, i.e. Rule 3019 Track Vehicles.

5.4.7.1 Track Access Accreditation – Rule 1004

Only persons who hold a current Track Access Permit (TAP) issued by the PTA are permitted to enter and work in the rail corridor.

5.4.8 Construction Rule Book

It is recognised by all stakeholders that the Project will transition through various stages of construction. It will not be practical to have only two safety management systems applicable to work, that being as a purely green fields construction site or work on an operating rail network under the PTA accreditation.

In reality there will need to be transitional arrangements where the Project moves from one state to the other with risk adequately managed.

A Construction Rule Book will be developed by the Alliance in consultation with all relevant stakeholders. This Rule book will define how work is to be done when in the transition phase of working under the PTA Safeworking Rules and Procedures to the Alliance Management System during the front end of the 18-month

shutdown. It will then also address the transition from green fields construction under the Alliance Management System back to the PTA Safeworking Rules and Procedures.

This Construction Rule Book will be developed and submitted to PTA for approval taking into account the 28-day review period by both PTA and ONSR.

5.5 Emergency Management

In the case of an emergency onsite, the Alliance Emergency Management Plan (EMP) will be enacted with those with roles named in the EMP completing their responsibilities as required.

As part of the EMP, the alliance will engage with emergency services to ensure that emergency operations are not adversely impacted by construction activities. This engagement will also brief the emergency services of Alliance's emergency procedures.

To manage emergency access and egress to and from the viaduct, the Alliance will provide egress towers (with stretcher access) at nominal 250m spacings along the viaduct. Evacuation drills will also be carried out in accordance with the Alliance EMP to ensure all personnel are aware of the emergency procedures.

5.6 Safety Risk Management

During design, the Construction Team will participate in the design team lead Safety in Design (SiD) process throughout the design phase of the project. This process is further detailed in the Engineering Management Plan (LXR-ALUA-EA-PLN-00001) (EMP). The hazards identified during this process will be addressed in design development with any residual risks then covered during the CRAW process.

The CRAW process is detailed in the Safety Management Plan (LXR-ALUA-SA-PLN-00001). Numerous CRAWs will be conducted prior and during the construction phase with all relevant and available loss to attend and participate.

5.7 COVID-19

The Construction Plan has considered the current COVID-19 requirements and have developed an Alliance COVID-19 Management Plan (COVIDMP) based on current conditions. This plan (including amendments this plan) will be subject to change based on change in government directions to the approval of the Alliance Management Team.

5.8 Incident Management

All incident reporting, investigation, and management will be carried out as per the Alliance Safety Management Plan.

6. Risk Management

Along with Safety risks, there are other risks which the construction phase will need to manage. These include but not limited to commercial, community and program. The management of risk for the Alliance will be in accordance with the Risk Management Plan (LXR-ALUA-RI-PLN-00001) which the construction team will comply with and contribute to. This includes conducting risk assessments and the detailing of risk mitigation procedures. The identified risks with mitigation measures will be included in the Risk and Opportunity Register for the Alliance. The Risk and Opportunity register will be reviewed and updated as per the RMP and prior to major items of works commencing to identify undetected or emerging construction risks.

6.1 Planning

An important process to minimise risk is adequate planning. Planning for the construction team will include various tasks to optimise planning such as:

- Weekly Construction Team to discuss Action list and identify activities to be planned
- Identify key requirements to be delivered by the activity
- Planning workshops with relevant stakeholders such as engineers and supervisors to detail construction methodologies to complete activities
- Finalisation of methodology and associated supporting documentation into a work pack. This will include the required schedule to be delivered, the deliverables and associated risks
- During the completion of activity regular observations and checks will be conducted to track progress and compliance with the requirements and deliverables, and
- Quality documentation for submission with completion and acceptance in compliance with the Completion and Acceptance Management Plan.

6.2 Work Pack

The work packs will be developed to ensure that the following information is communicated effectively to the project team responsible for delivery of the works prior to commencement of the activity:

- Activity overview
- Sequencing and staging of the works
- Risk assessments
- Approvals and permits (including dig permits with service location details, as required)
- TCDs as required
- Rail Safe working Sub-plan, as required
- Resource requirements
- Relevant drawings and specifications, and
- ITPs and verification checklists.

7. Environment

The following sub-sections are to be read in conjunction with Construction Environmental Management Plan (CEMP) (LXR-ALUA-EN-PLN-00001). The CEMP details the environmental risks and the management process to manage these.

7.1 Discharge Water Quality

All water including groundwater seepage captured within the Construction Site must be treated and disposed of in accordance with the requirements of the PAA, SWTC and the relevant Government Agencies.

The Alliance will monitor the quality of water discharged from the Construction Site.

7.2 Construction Noise and Vibration

The CEMP has included sections addressing construction noise and vibration and will define the management parameters for construction noise and vibration on receptors adjacent to the site. The objectives of the noise and vibration section of the CEMP are:

- Manage noise emissions extending beyond the Construction Footprint and minimise the effects on adjacent receivers
- Minimise and manage vibration generation from construction works and reduce impacts to adjacent receivers
- All noise emitted from construction works are to comply with State Environmental Protection Act 1986 and Environmental Protection (Noise) Regulation 1997
- Undertake works in accordance with control of noise practices set out in Section 6 of AS 2436-1981 Guide to Noise Control on Construction, Maintenance and Demolition Sites, and
- Works and activities are to be undertaken in methods that will minimise noise and vibration levels produced and the associated negative impacts on sensitive receivers.

Further to this the CEMP will detail the management of the sensitive receivers including but not limited to completing condition surveys within the required radius of the works.

7.3 Noise

The potential impacts of noise on any particular location can vary greatly depending on factors such as the relative proximity of sensitive receptors to the source of the noise, the overall duration of works undertaken, and the character of the noise generated by the works. Activities associated with construction works have the potential to increase localised noise, impacting on the community and public adjacent to the project area.

The Alliance recognise that the Project occurs adjacent to a variety of neighbourhood types with receivers of various sensitivities. Hence noise is a critical consideration for the project team.

A wide range of plant including excavators, graders, loaders, vibratory rollers, tipper trucks, compactors, lifting and access equipment, drilling and piling machinery and rattle guns will be used during the construction phase of the project. Noise and vibration from these items will consist of steady production as well as some impulsive components.

Stationery plant such as generators and compressors will also be required, with noise from these items being mainly steady in nature. Deliveries shall be completed in standard working hours unless not fitting within "construction works".

Nightshift works are likely during railway shutdown periods and the nature and extent of these interruptions is important to quantify so as to be able to make the necessary plans to advise impacted parties.

7.3.1 Noise Targets

Noise levels will be monitored with the aim to understand noise generated as a result of construction activities. Intervention and Action targets will be developed in the CEMP. The Alliance will use quantitative data from monitoring and qualitative data from stakeholders to understand noise emissions on-site. While the Projects aim to receive no noise complaints from the public, if received, the Alliance will utilise these reports to better assess noise propagation and attenuation from works. All works shall comply with occupational health and safety guidelines and be conducted in accordance with the Environmental Protection Noise Regulations 1997, Section 4.5 of AS 2436 – 2010 Guide to Noise Control on Construction, Maintenance and Demolition Sites, and with reference to State Planning Policy 5.4 (WAPC, 2009).

7.3.2 Noise Controls

The management practices listed below will be implemented on the Project to minimise noise impacts on the surrounding residences, and to address the requirements for the implementation of reasonable and feasible measures for the duration of the construction work. The noise controls listed below are consistent with AS 2436-2010 Guide to Noise Control on Construction, Maintenance and Demolition Sites and the SWTC.

- All construction works will be carried out within approved construction hours of 0700 hours to 1900 hours from Monday to Saturday (except public holidays), unless approved in a separate Out of Hours plan
- All construction work will be carried out in accordance with environmental noise control practices set out in Section 4.5 of AS 2436-2010 Guide to Noise Control on Construction, Maintenance and Demolition Sites
- All public complaints shall be recorded and investigated
- High noise generating works will be staggered where possible to minimise noise impacts
- Where practicable, excessively noisy processes will be substituted with alternative processes
- Site offices, compounds and workshops will be located so to minimise the impact on the noise amenity of nearby sensitive receptors
- On-site generators and auxiliary power sources used during construction will be positioned among existing buildings to buffer noise where possible
- Temporary acoustic fencing/barriers around noise intensive equipment/sites will be considered to mitigate high level off-site noise levels
- Plant and equipment will be located away from noise sensitive areas as far as practicable
- All 'warm-up' of equipment by employees and contractors arriving to site will be conducted during approved site construction hours
- Generators, machinery and vehicles are to be switched off when not in use
- In selecting plant and equipment for construction works, preference will be given to those which minimise noise and vibration
- Plant, machinery and vehicle reversing alarms will be broadband alarm type where required
- Maintain vehicle, plant, equipment maintenance schedules and lubrication as per manufacturers' specifications

- Regular checks (additional to scheduled maintenance) are to be undertaken to ensure all equipment and vehicles are in good working order and are being operated correctly (i.e. Daily Vehicle Daily Pre-start Checklist). Checklist includes:
 - Engine cover condition
 - Defective silencing equipment
 - Rattling components
 - Leakages in compressed air lines
- Toolbox and pre-start meetings on noise management requirements, sensitive receivers and measures will be completed during the project
- Environmental Toolboxes and pre-start briefings will be conducted, and work crews informed of the impacts of noise.
- Site vehicles to adhere to speed limits throughout the Project
- Vehicle movements will be restricted to approved access roads, and
- Behavioural practices to be enforced, i.e., no swearing or unnecessary shouting or loud stereos/radios on site. No dropping of materials from height, throwing of metal items and slamming of doors.

7.3.3 Noise Monitoring

The Alliance has made an allowance to observe noise volumes during approved out-of-hours works to confirm compliance with the CEMP and other requirements.

7.4 Vibration

The propagation of vibration caused by heavy machinery and more specifically plant and machinery designed to conduct vibratory activities can impact adjacent residences including occupants, buildings for residential, commercial and recreational purposes, heritage buildings/sites and public utilities and infrastructure. Vibration can not only cause aesthetic and structural damage if not monitored, but it can also generate community disruption, concern and complaints.

7.4.1 Vibration Impact Assessment

The intensity of vibration felt by a receiver can vary dependent on the strength of vibration produced from the source, the wave frequency, distance of separation and environmental factors, e.g., ground condition, topography, physical barriers etc. In general, vibration emissions beyond Project footprint are expected to be critical due to the proximity of sensitive receptors which include buildings with significant heritage.

Sensitive receptors are those premises which are most at risk to increases and the effects of vibration. For the Project these receptors include residential properties, commercial properties, heritage buildings and sites, disability services and operating railways. The Alliance will conduct a detailed vibration impact assessment based on the construction methodology, plant selection and prevailing site conditions to identify the potential impacts and receptors for the project. Consideration is to be given not only to the potential impacts upon structures but the human vibration response. On completing these assessments, the Alliance will:

- Identify the requirement for additional condition surveys
- Establish and maintain vibration targets
- Establish vibration monitoring to protect sensitive receivers

- Implement vibration controls to minimise impacts to adjacent receivers and infrastructure during works.

7.4.2 Vibration Targets

Vibration emissions are to be monitored based on the Impact Assessment findings and relevant nearby receptors. Intervention and Actions targets will be established through the Impact Assessment and will either be constant over the Project or be developed with allowable ranges at specific locations based on the nearby receivers, construction methods and distance separation. Vibration received at premises due to construction works should not exceed 5mm/s Peak Particle Velocity (ppv) so to prevent structural damage to buildings. An early warning indicator of 3mm/s is to be used to assist in regulating vibration intensive works. The Alliance will strive to complete works with no community complaints but in cases complaints are received each case will be reviewed and investigated.

Due to the importance of quantitative data provided by vibration monitoring equipment units must meet the requirements of BS 5228-2:2009+A1:2014 Code of Practice for Noise and Vibration Control on Construction and Open Sites—Vibration; BS 7385-2:1993 Evaluation and Measurement for Vibration in Buildings—to Damage Levels for Ground borne Vibration; and DIN 45669-1:2010 Measurement of Vibration Emission Part 1 Vibration Meters requirements and Tests, where applicable.

7.4.3 Vibration Controls

Construction vibration management measures detailed below will be employed by the Alliance throughout the Project to maintain vibration levels within the target criteria, especially with regards to sensitive receivers. The management measures are in accordance with Section 6 of AS 2436-2010 Guide to Noise and Vibration Control on Construction, Demolition and Maintenance Sites and have been derived with guidance from BS 5228-2:2009+A1:2014 Code of Practice for Noise and Vibration Control on Construction and Open Sites—Vibration but also with reference to AS 2670.2: Evaluation of Human Exposure to Whole Body Vibration:

- Selection, where practicable, of construction methodologies that minimise the generation of vibration
- Selection, where practicable, of plant/machinery to minimise low frequency generation of vibration (e.g., selection of higher frequency generation of plant/machinery)
- During construction activities, ground vibration will be monitored at selected locations where there is the potential to impact local receptors
- Where plant and machinery may exceed limits during operation, i.e., Vibratory Roller, these items will have set designated distance off-sets from relevant boundaries
- All construction work will be carried out within the approved construction hours of 0700 to 1900 hours Monday to Saturday (except public holidays) unless approved in a separate Out of Hours CNVMP
- All public complaints to be recorded and investigated. Where complaints relating to construction vibration are received, vibration monitoring will be undertaken to verify compliance with the specified limits
- Awareness training and information will be provided to project personnel in relation to the vibration limits on the project and the need to minimise vibration during the works
- Environmental Toolboxes and pre-start briefings will be conducted, and work crews informed of the impacts of vibration generating plant/machinery
- Where possible works are to be scheduled in order to reduce the impact of intensive vibration generating activities on sensitive receivers
- Where structural vibration action targets are exceeded, the offending process will be reviewed, and alternative equipment or methodology will be evaluated

7.4.4 Vibration Monitoring

Vibration trials of specific plant and machinery may be conducted prior to vibration-intensive activities that may have an impact on receptors so to gauge potential setback distances or designated start-up locations.

7.5 Heritage Management

The CEMP addresses in further detail the acknowledgment by the Alliance that Aboriginal heritage concerns remain a key focus, and as is detailed in the CEMP, have implemented where possible, reasonable, and practicable measures for ensuring that activities are managed to avoid or minimise harm to Aboriginal sites. A key component of this will be the engagement of Aboriginal monitors during ground disturbance activities.

7.6 Out of Hours Works

Construction outside of 0700 to 1900 hours Monday to Saturday (except public holidays) may be required from time to time to conduct particular essential scopes of work. These activities will be managed as out-of-hours works applications in accordance with Environmental Protection (Noise) Regulations 1997 WA for the approval of the local government authority, DWER and subsequently by the PTA's Representative. An Out of Hours Noise and Vibration Plan application must be submitted to the LGA seven days prior to the works being proposed to be undertaken and must include the following:

- Reasons for the work to be completed out of hours
- Proposed noise and/or vibratory activities
- Impact of construction lighting
- Predictions of noise levels from the site
- Predictions/assurance of vibration levels from site
- Monitoring of noise and vibration
- Notifications to residents and Stakeholders of upcoming out of hours work, and
- Complaint response procedures.
- Typical strategies on how noise & vibration will be managed may include;
 - Respite periods
 - Non tonal alarms
 - Staging of works
 - Alternative equipment / methods where possible
 - OOHW Personnel Etiquette
 - Transparency with sensitive receivers and LGAs

Prior to the submission of any out-of-hours works applications to the relevant local government authorities, an internal approval process for such works will first be carried out by the Alliance construction team. The construction lead will first obtain internal approvals from the relevant disciplines (i.e. Construction Manager, Sustainability and Environment Manager, Health and Safety Manager) and then submit a Permit to Notify (PtN) that informs the Community & Stakeholder team to commence the notification process. These out of hours works will then be stored on a register.

7.7 Out of Hours Public Notification

As part of an Out-of-Hours works application the predictions of noise will provide an estimation of the potentially impacted premises. Occupants of nearby effected buildings likely to receive noise levels in excess of Assigned Noise Levels defined within Environmental Protection (Noise) Regulations 1997 (WA) must be advised (i.e., letter drop) at least 24 hours prior to work commencing. The notification must provide reasons to why the work is necessary, reference to the LGA approval and contact details to register complaints.

7.7.1 Target Exceedances and Complaints

Where noise or vibration targets are reached or a complaint regarding nuisance levels are received the Alliance will investigate the cause or potential source. The investigation may include the deployment of monitoring equipment to measure noise or vibration levels so to demonstrate compliance or alternatively the modification of the work methodology to reduce noise or vibration impacts. If noise or vibration levels are recorded in excess, the work must be modified to be conducted within allowable limits prior to continuing. Any recorded exceedances shall be provided to the PTA in the monthly environmental report.

7.8 Construction Water

Water used by the Alliance for construction purposes will be obtained from sources other than Water Corporation water supply service, Conservation Category and Resource Enhancement Wetlands or surface water bodies unless it can be demonstrated to the satisfaction of the PTA's Representative that alternatives are not viable, and all required approvals have been obtained.

There are a number of groundwater abstraction license holders who are authorised to abstract groundwater from the groundwater management and sub-management areas that the Project is located within. The Alliance will obtain all required approvals and undertake all required investigations and assessments, including an assessment of the available groundwater allocation, prior to using groundwater for construction purposes.

7.9 Site Reinstatement

The project is not intended to be decommissioned; however, areas that do not provide permanent infrastructure will be landscaped and rehabilitated to a similar or improved condition prior to works having been conducted.

Trees that are to be afforded protection as per the tree management report (as required by the DA) shall be surveyed and protected was per the following:

- Provide a Tree Protection Zone (TPZ) as identified by project arborist
- Fencing is not to be moved or removed at any period
- Signage notifying people of the TPZ and other requirements placed on each side of the fencing
- Any roots identified to be pruned should be pruned with a final cut to be undamaged wood outside of the TPZ. Pruning cuts should be made with sharp tools such as secateurs, pruners, handsaws or chainsaws. Pruning wounds should not be treated with dressings or paints. It is not acceptable for roots to be pruned with machinery such as backhoes or excavators
- All retained street tree(s) within the development site shall have measures consistent with AS 4970-2009 undertaken to ensure their protection during construction of the subject development.

All land areas used for construction supporting activities (i.e., laydown, office) within the site shall be surveyed by the environmental team. The survey shall comprise vegetation and topsoil assessment and be mapped in accordance with the vegetation condition scale (Keighery, 1994). The reinstatement shall match (as a minimum) the pre-construction classification.

Re-instatement of all land used to support construction activities outside of the site shall be subject to the obligations as specified by the landowner, and any applicable approval/licensing conditions or approving authorities.

The following requirements shall be considered:

- The existing ground should be reinstated to meet the requirements of the pre-construction or future land-use (as approved), followed by placement of topsoil and revegetated as soon as possible, dependent on season
- The site will be revegetated, to match pre-existing vegetation types, and percentage of ground covered by vegetation. Vegetation types shall be consistent with the neighbouring land-use
- Rehabilitation shall be monitored against the site's nominated success criteria
- Consider the need for ongoing rehabilitation maintenance activities such as weed control and fencing, and
- Prepare documentation to hand the site back to the relevant landowner.

Any adjacent areas that have been damaged during construction activities will be repaired and/or reinstated to at least equivalent to the existing prior to the works unless otherwise stated. Reinstatement works may include the careful removal of redundant pavements, paths, foundations, embankments and furniture including backfill with appropriate material and reinstatement of disturbed or damaged pavements or surfaces.

7.10 Storage of Materials

Materials will be handled and stored onsite to protect them from damage, degradation, loss, theft, vandalism and corrosion where applicable:

- Design to consider requirements for delivery and storage as well as durability requirements
- Secure location identified onsite for storage of materials protected from site works and movements
- Protection in place to prevent unauthorised access included secure fencing and security
- Materials to be handled and stored in accordance with manufacturers recommendations and product MDS
- Supplier packaging to remain in place until required to be removed for installation or operation, whichever the latest, and
- Final clean to be conducted to remove any foreign material and dirt to prevent degradation and corrosion.

Further to the above refer to the:

- Quality Management Plan (LXR-ALUA-QA-PLN-00001)
- Procurement and Participation Plan (LXR-ALUA-PR-PLN-00001)
- Engineering Management Plan (LXR-ALUA-EA-PLN-00001), and
- Durability Plan (LXR-ALUA-TBC-0000X).

7.11 Existing Ground

During performance of the Works, the Alliance will log, sample for Testing, and classify the excavated ground materials in accordance with AS 1726:2017 for the purposes of:

- Materials re-use suitability
- Identification of Project risks
- Assessment for contamination
- Verification of design assumptions.

The Alliance will also update the existing geotechnical longitudinal sections based on the actual materials encountered during the performance of the Works. As a minimum, these updated longitudinal geotechnical sections must be prepared to the same level of detail as the existing geotechnical longitudinal sections; and be provided to the PTA in Adobe PDF, AutoCAD, and AGS4 (for geotechnical data) digital media formats.

8. Quality Assurance

The Alliance Quality Plan (LXR-ALUA-QA-PLN-00001) defines the practices, resources, authorities and underpinning activities that will be undertaken by the Alliance to provide assurance that all works shall be managed and controlled in a manner to meet the requirements of the SWTC including the design, durability and technical specification. The Alliance Quality Plan contains references to how the following will be addressed and managed:

- Quality of Materials and Workmanship
- Verification documentation required including ITPs and checklists which confirm quality of workmanship where workmanship can affect compliance, warranties, fitness for purpose or operations
- Details of hold and witness points to be addressed during construction progression
- Construction Records/As-Constructed Documentation
- Close out requirements for established lots
- Design Changes and Non-Conformances during Construction
- Management of defects
- Monitoring during the Non-conformance Correction Period
- Record of any other monitoring or Testing undertaken
- Maintenance by Others during Non-conformance Correction Period, and
- Documents and Records Management.

Refer to the Quality Plan for more detail on the above.

Furthermore, for the construction, the purpose of the Quality Management Plan is to describe how the Alliance will manage, control and verify the Quality Control (QC) aspects associated with the project through this phase.

This Alliance Quality Plan has been established to:

- Define elements of the Alliance's Quality Management System (QMS) that are applicable for the Project and how they are to be applied
- Assist the Project Management Team in understanding their operational and project responsibilities
- Identify measure, control and address all project Quality Assurance (QA) and QC requirements, including preventative measures for potential non-conformities
- Continually review the effectiveness of controls and take appropriate measures to deliver a successful Project
- Define the management practices that will be implemented to ensure that the scope of work is executed in accordance with its contractual requirements and obligations
- Provide confirmation of the roles and responsibilities of relevant parties in the Project's structure
- Agree processes for management of change, problems, issues and incidents that emerge during the Project, and
- Provide a comprehensive overview of quality methodologies and standards to be adopted in managing the Project.

All equipment and materials will be handled and stored appropriately to ensure no damage or degradation occurs, and all equipment and materials must be protected from damage that could be caused by animals or acts of vandalism.

Assets will be protected through design and installation from corrosion.

Assets will be fitted in a manner to meet OS&H, human factor standards, aesthetics and maintainability requirements.

3D digital models in The Alliance will ensure all Construction Records and As-Constructed Documentation is prepared and delivered in accordance with PTA documents:

- 7610-000-010 - Quality Management - Contractor Standard
- 8103-000-005 - Procedure: Deliverables Review
- 8110-100-012 - Procedure: Drawing Management
- 8110-100-013 - Procedure: Engineering Management for Projects
- 8110-300-011 - Procedure for Preparation of Computer Aided Drawings
- 8110-400-013 - Procedure: for Entry into Service and Final Asset Acceptance.

The Alliance will submit sample As-Built Records and Documentation for all Assets for review and Acceptance by the PTA's Representative prior to production of any As-Constructed Documentation.

The Alliance will ensure Records and Documentation complies with all applicable SWTC requirements, or as otherwise instructed by the PTA's Representative in writing.

The Alliance will, where necessary to describe the Works or where directed by the PTA's Representative, include digital photographs and/or digitally surveyed models of specific aspects of the Works in As-Constructed Documentation.

The Alliance will identify and progressively cross-reference all Assets and elements of work, against the project's work and system breakdown structures during the Design and Construction phases, and within the relevant Records and As-Constructed Documentation.

The Alliance will ensure that information and data stored and/or authored in the 3D graphical model/BIM is retained as the single information source. This includes all drawing outputs derived and edited from the 3D graphical model/BIM throughout the lifecycle of the Assets.

As a condition of achieving Practical Completion and further to the definition of Practical Completion within the PAA, the Alliance will deliver to the PTA's Representative the following:

- A complete set of SWTC compliant (or change process approved) As-Constructed information as listed and further noted within 7610-000-010 - Quality Management Systems Contractor Standard
- Certification from a licensed surveyor with a current practicing certificate that the Works are located as shown on the As-Constructed Drawings and within the Project's approved land constraints and boundaries
- Design Documentation presented and numbered in accordance with the PTA documentation and drafting standards, and
- BIM requirements as stated in SWTC Book 2, Management Requirements and Associated Requirements Advertising: Digital Engineering Management Plan.

As part of the supply of data during Construction and As-Constructed Documentation, the Alliance will provide drawings and 3D digital models in accordance with SWTC Book 2, Management Requirements and Associated Requirements: DE Management Plan.

The Alliance will keep up-to-date in the use and application of materials and of the progress of all work undertaken, all plant and equipment used for each part of the work, the Personnel roles and number of Personnel for each part of the work, details of any obstruction, progress issue, plant failure, safety event or near miss, and any incident.

9. Survey

The Alliance is responsible for any survey work necessary to design and construct the Works. This work shall include:

- Digital ground survey and production of DTM of the area of to be affected by the Works for final design
- Establishment of survey control network as the basis of the digital ground survey and the setting out and compliance checking of the Works. Reference marks will be established and submitted in accordance with PTA and Main Roads Mapping Standards:
 - PTA technical procedure 5610-350-001.0 – Rail Reference Marks
 - Main Roads WA technical standard 67-08-35 – Standard Survey Mark Control
 - Main Roads WA technical standard 67-08-36 – Road Reference Marks
 - Main Roads WA technical standard 67-08-37 – Minor Control Points,
 - Main Roads WA technical standard 67-08-38 – Differential Levelling, and
 - Quality Statements will be supplied in accordance with Main Roads Guideline Document No. D12#434784 Metadata Requirements for all survey data.
- Setting out the works
- Monitoring and quality control during construction
- Establishment of track survey monuments including those for OLE mast monitoring. The Geotechnical Plan provides more information including for settlement monitoring
- Construction audit surveys
- Integration of all survey information into the BIM model (where applicable)
- As constructed surveys and drawings of all completed work will be submitted to the PTA's Representative prior to Practical Completion, and
- Settlement monitoring of all existing bridge and tunnel structures in the project area will be undertaken Main Roads WA technical standard 67-08-108 Settlement Monitoring.

The BIM will be progressively updated to the As-Built condition during construction phase to enable monitoring of the program during project activities and managed in accordance with the Digital Engineering Management Plan (LXR-ALUA-DE-PLN-00001) (DEMP).

The survey and mapping data used to prepare the PTA preliminary design for this Project is a collection of data from various sources over a period of time, with varying accuracy. All survey work will be connected to the Geocentric Datum of Australia 2020 (GDA2020) and the Australian Height Datum (AHD). All design and survey plan coordinates will refer to the Perth Coastal Grid 2020 (PCG2020) in metres.

The current MRWA Survey and Mapping Standards are available from the Surveying and Geospatial Services section of the MRWA website: www.mainroads.wa.gov.au.

The Alliance will develop a comprehensive detailed ground survey of the Project corridor for the creation of a full Digital Terrain Model (DTM) of the existing surface in accordance with Main Roads' Survey and Mapping Standard 67-08-43 Digital Ground Survey.

All existing survey marks within the Construction Site will be protected until the end of the Non-conformance Correction Period. This includes cadastral survey marks defining property boundaries and the road reserve, rail reference marks, Main Roads RRM's, State Survey Marks (SSM) and Benchmarks (BM).

The Alliance will be aware of these marks and is responsible for all associated re-establishment costs as a result of any disturbance to or movement of these marks resulting from the Works.

The Alliance will establish the location of all property boundaries which are affected by the Works. Such boundaries include those upon which any part of the Works are located or are dependent upon. A Licensed Surveyor with a current practicing certificate will set out all property boundary survey work and supply a "Regulation 25A Certificate" to the PTA's Representative prior to any work affecting property boundaries.

All survey and mapping information for the Works will be lodged with the PTA's Representative for registration with the PTA, as outlined in the MRWA Survey and Mapping Standard 67-08-119 Data Lodgement.

9.1 Coordinates and Datum

- All survey work is to be connected to the Geocentric Datum of Australia (GDA2020) and the Australian Height Datum (AHD)
- All design and survey plan coordinates must refer to the Perth Coastal Grid 2020 (PCG2020).

9.2 Personnel

All survey personnel engaged on the project must satisfy the following criteria:

- Licensed Surveyors must have a current practicing certificate as issued by the Land Surveyors Licensing Board of Western Australia
- Engineering Surveyors must be eligible for accreditation to the certification level of "Engineering Survey Professional – Asia Pacific" as defined by the SSSI.

9.3 Existing Survey and Mapping Data

The survey and mapping data supplied for this Project is a collection of data from various sources over a period of time, with varying accuracy. The Alliance have analysed this data for its accuracy and completeness and will undertake additional surveys and assessments to facilitate detailed design such as the area to the east of the proposed platforms location.

9.4 Protection of Survey Control

- All existing survey marks within the project zone must be protected until the Non-conformance Correction Period. This includes cadastral survey marks defining property boundaries, rail reference marks, RRM's, SSM's, BM's and permanent survey marks
- Reinstatement of damaged or disturbed marks will be at the cost of the Alliance
- Re-establishing cadastral marks will be in accordance with applicable acts and regulations, all re-establishment surveys must be carried out by a Licensed Surveyor with a current practicing certificate, and a "Regulation 25A Certificate" provided to the PTA's representative in accordance with the regulation
- Re-establishment of RRM's will be undertaken in accordance with Main Roads WA Standard 67-08-36 Road Reference Marks
- SSM's and BM's will be relocated or replaced through Landgate, and
- Prior to any disturbance to the primary control marks, RRM's, SSM's and BM's the Alliance will notify the PTA's Representative.

10. Resources

10.1 Labour

The Alliance has a duty as an employer under Section 19 of the Occupational Safety and Health Act 1984 to provide information, instruction, training and supervision for employees to enable them to perform their work in such a manner that they are not exposed to hazards.

In addition, Section 117 of the Rail Safety National Law (WA) Act 2015 requires an RTO to ensure that each Rail Safety Worker is accredited and has the competency to carry out that work.

The Project will undertake a Training Needs Analysis in reference against the Project Scope of Works and in accordance with PTA's site requirements. A Project-specific Training Management Plan will be used to detail the training required.

The primary Alliance reference for training management is the Training Management Plan. The People and Culture Manager, in conjunction with the relevant discipline manager will determine minimum competency requirements for staff appointed to key project positions. Potential subcontractors and suppliers will be assessed on their ability to supply personnel with the competencies required to complete the activity or task.

Where training is Project-specific, or there is an identified skills gap that cannot be easily filled by procurement, the People and Culture Manager will coordinate the delivery of training to meet the competency requirement for the Project. Any training provided by the Alliance will be on a needs basis, and (apart from trainees and trade apprentices) will generally be restricted to:

- Construction Industry general WHS induction (White Card)
- Project and site inductions
- Third party inductions, if required
- PTA Supervised worker
- Risk Management, and
- Other specialist skills training as necessary.

Training to provide railway safeworking or supervised worker qualifications for the PTA Safeworking Rules and Procedures is provided by the PTA. Where a specific construction railway safety rulebook is developed for use in the greenfields railway environment ALUA may develop its own rulebook and its own training.

10.2 Plant and Equipment

10.2.1 Certification of Road/Rail Vehicles

The Alliance, including partnering subcontractors, will operate track machines, rail plant, and hi-rail vehicles on rails (collectively termed as rolling stock) for construction and commissioning of the Project. The Alliance shall ensure that all rolling stock shall be compliant with the PTA's certification requirements for road-rail vehicles, as detailed in Certification Requirements of Hi Rail Vehicles and 8110-400-029 "Applying For Access to the PTA Operating Railway Reserve and PTA Certification of Road Rail Vehicles Parts 1, 2 and 3".

The Alliance will submit the technical details of all rolling stock to PTA as appropriate for certification in accordance with the PTA registration and certification procedures and comply with the safe working rules and procedures for the operation of rolling stock on the applicable railway network. Certification of all rolling stock shall occur prior to operation on the PTA network the certification shall be on accordance with:

- Part 1 – Overview and Engineering Assessment (PTA Doc No. 4010-100- 101)
- Part 2 – Interface and Technical Requirements (PTA Doc No. 4010-100-103)
- Part 3 – Vehicle Information and Test Results (PTA Doc No. 4010-100-102), and
- Section 5 – Safety Instructions for the Electrified Area (PTA Doc No. 8110- 800-016).

Prior to rolling stock operating within the electrified area of the PTA rail network, all rolling stock shall be presented for inspection and certification by a nominated PTA representative.

Rolling stock operators will be required to hold current rolling stock operator training and competency approved by PTA as appropriate.

The Rail Safety Manager is responsible for managing and recording the certification for all rolling stock operated by the Alliance or its subcontractors/suppliers.

Track machines and rail plant will be stabled in a suitable location as agreed with the PTA as appropriate before the rolling stock is allowed on site. Notwithstanding, rolling stock that is operating on disconnected sections of track under the project Construction Rule Book may be stabled in situ if approved by the RTO/Controlling Authority.

10.2.2 Operation of Construction Plant and Equipment

All Plant and Equipment required for the completion of the works shall be operated in accordance the minimum requirements for the safe operation of plant, mobile equipment and light vehicles as detailed in the SMP and in particular HSE-OMR-002 – Plant, Traffic and People. The minimum requirements aim to:

- ensure all persons directly responsible for the operation of plant are aware of the associated hazards
- demonstrate that residual risks are tolerable and are reduced to ALARP
- formally record the actions taken to identify and control hazards associated with the operation of plant
- identify requirements of Plant Registration
- define monitoring requirements
- satisfy regulatory compliance
- ensure the storage of Maintenance Records, and

10.2.3 Plant and Equipment Pre-mobilisation Inspections

In keeping with Operational and Environmental requirements, all Plant and Equipment mobilised to the Project shall be required to undergo Pre-Mobilisation Inspections.

Plant and equipment mobilisation will be managed through Lucidity as detailed in the SMP in particular IMS-PRO-016 Plant and Equipment.

10.2.4 Plant and Equipment Service and Maintenance

The scale of the work for the project and the related plant and equipment is such that a permanent workshop is not required to be based onsite.

Minor services or repairs will be completed at a designated location onsite by qualified personnel who are mobilised to site for this specific purpose. For a major service or repairs plant shall be mobilised off site to the responsible vendors' nominated location.

A Minor Repair shall be defined as actual or anticipated component or item failure in areas that are not in major oil containing compartments or preventative maintenance. A Major Repair shall be defined as actual or anticipated component failure in a major oil-containing compartment of the plant. These include:

- Main Engines
- Transmissions
- Differentials/Final Drives, and
- Implement Pumps.

10.2.5 Operation of Vehicles

The Alliance shall comply with Part 3 of the Road Traffic (Vehicle Standards) Regulations 2002 (WA) when operating vehicles on public roads travelling to and around the construction site.

The Alliance must operate vehicles with total or axle mass in excess of these limits within the Construction Site, subject to the following conditions:

- The operation of vehicles with excess mass will not be permitted on partially or fully completed pavement work, service pits, drainage or structures
- The operation of vehicles with excess mass must be limited to vehicles which have been loaded within the Construction Site only and be limited to manufacturer's specifications. Operation in excess of manufacturer's specifications is not permitted
- All on track road-rail vehicles shall be presented for inspection and certification by a nominated representative of the PTA before they can be used within the electrified area, and
- On track road-rail vehicles shall only be used within the electrified area once the line has been de-energised and in accordance with the Network Rules 2000 and the appendix to the Network Rules.

10.2.5.1 Keeping Pedestrians and Vehicles Apart

The Alliance will implement the following control measures to keep pedestrians and vehicles apart at the construction workplace and when vehicles enter or exit the workplace:

- Providing separate traffic routes for pedestrians and vehicles, where possible
- Providing separate clearly marked pedestrian walkways that take a direct route
- Creating pedestrian exclusion zones where powered mobile plant is operating
- Providing clearly signed and lit crossing points where walkways cross roadways, so drivers and pedestrians can see each other clearly
- Scheduling work so vehicles, powered mobile plant and pedestrians are not in the area at the same time, and
- Where required install delineation between pedestrians and vehicles with type to be determined based on a risk assessment completed with each situation. Delineation include but not limited to flagging, windrows, crowd control fencing, temporary fencing, concrete barriers etc.

A Site Layout Plan will be developed and maintained to detail the above controls as they appear onsite. This will be shared with the wider project team via prestart briefings and on-site noticeboard plus other forms of communication.

10.2.5.2 Minimise Vehicle Movements

Planning can help minimise vehicle movements around a workplace. To limit the number of vehicles, the Alliance will:

- Plan storage areas so delivery vehicles do not have to cross the site
- Provide alternative and encourage alternative methods for construction workers to attend site
- Controlling entry to the work area
- Scheduling work to minimise the number of vehicles operating in the same area at the same time.

10.2.5.3 Reversing Vehicles

Where possible, the Alliance will avoid the need for vehicles to reverse as this is a common cause of plant interaction incidents.

One-way road systems and turning circles can minimise, especially in storage areas. Where this is not possible other control measures should be implemented including:

- Using mirrors, reversing warning alarms, sensors and cameras
- Ensuring a spotter wearing high visibility clothing assists the driver who cannot see clearly behind their vehicle – the driver should always be able to see the spotter
- Ensuring workers and other people are familiar with reversing areas and these areas are clearly marked, and
- Ensuring plant operators are aware of workers who may be in the vicinity of the swing radius, articulation points and overhead load movement of their vehicle.

Signs will be used to alert workers and to potential hazards from vehicles entering and exiting the construction workplace, and other requirements like pedestrian exclusion zones.

10.3 Subcontractors

The Alliance will engage subcontractors, suppliers and consultants to deliver or assist in delivering portions of the works in accordance with IMS-PRO-010 Contractor and Supplier Management. The Construction Management Team will engage with the subcontractors, suppliers and consultants to ensure understanding of and adherence to the project's management plans. The same standards set for direct labour will be applied to all that are engaged in the project.

10.3.1 Subcontractor Interface Management

As there will be numerous subcontractors onsite, the management of subcontractor interface will be crucial for productivity and safety onsite. The interfaces will be managed by:

- Planning before commencement of construction
- Kick off and ongoing formal regular meetings with individual subcontractors to identify requirements for and constraints from other subcontractors
- Prestart meetings on a daily basis where interfaces with all Subcontractors are identified and details of management discussed
- Day-to-day informal discussions amongst supervisors as required.

The General Superintendent will have ultimate responsibility of management of interface and will provide direction in times of competing requirements.

10.4 Key Resources

ALUA understands that within the current and upcoming construction market, certainly of resources is critical for the successful delivery of the project. Procurement of plant, materials and long lead items will be managed by the Procurement Manager with oversight by the Commercial manager and support from the Construction team.

Our approach to procurement is based on:

- Leveraging quantities on a project-wide basis and making use of existing agreements within the NOPs to realise buying gains opportunities
- Developing subcontract packages to enable smaller suppliers to tender for works to support competitive pricing and industry participation
- Identifying high performing subcontractors from previous projects for consideration in supplier shortlisting
- Procuring specialist plant such as rail, overhead and signalling on a best-for-project basis
- Engaging early with long lead suppliers.

Procurement will be managed using a schedule that identifies and tracks all packages required for the project. Materials and services will be procured when design development is at a stage that results in price certainty and allows competitive tension wherever possible. As a component of the procurement schedule, the Alliance will also use a long lead item register that maps out the key construction activities against the schedule activity codes that are driven by their required on-site date.

To mitigate escalation pressures, supply constraints and program pressure, ALUA has entered into early agreements for critical packages as defined in the ALUA Procurement and Participation Plan

11. Community Engagement

The Community Engagement Plan and Stakeholder Interface Management Plan (LXR-ALUA-SM-PLN-00001) outline the Alliance's approach to community and stakeholder engagement.

11.1 Stakeholder and Community Management

11.1.1 PTA Metropolitan Rail Network

The Alliance plans on zero unplanned disruptions to the normal operation of the metropolitan rail network including unplanned disruptions by passengers to the station. This Construction Plan, along with other Management Plans detail how this will be achieved.

In summary unplanned disruptions will be managed by:

- Completing risk assessments for all critical works activities to identify those that have the potential to impact the rail network
- Identify and implement controls to mitigate the risk of impact on the rail network
- If required complete Rail Safe working Sub-Plan to the SMP for the approval of the PTA
- Liaise and consult with PTA representatives and other stakeholders to confirm plans are suitable
- Create Work Plans to ensure required information is with those that are completing the works
- Continual oversight, review and audit of onsite activities to ensure work is being completed in accordance with the Work Plans and that no new risks eventuate that have not been previously identified.

11.1.2 Overhead Clearances

A height clearance of no less than the specified minimum road to soffit clearances (as specified within the designs) will be maintained on all roads open to traffic unless effective advance warning devices are provided. Care shall be taken during staging of the works to ensure that minimum clearances are not present due to staged construction.

11.1.3 Security of Adjacent Properties

Security of all properties affected by all Works will be maintained at all times to a standard equivalent to that which currently exists.

As outlined in the Community Engagement Plan, the Alliance's communications representative will provide information to the PTA's Project Communications Manager a minimum of 10-days prior to any potential disruptive activity occurring.

The Alliance's Community and Stakeholder Engagement Team will prepare specific communication action plans for issues, disruptions and milestones that will be anticipated for use throughout the project. These communications actions plan will be developed to manage:

- Major shutdowns
- Disruptions/disturbances access to property, machinery noise, vibration, dust, visual or pollution, potential property damage
- Road closures, cycle path closures
- Works to be undertaken outside of normal hours (Monday to Saturday 0700 to 1900 excluding public holidays), and

- Service and passenger disruptions on the Transperth Network.

Any project activities that will occur outside of normal hours (Monday to Saturday 0700 to 1900) will be communicated to the local community. The Alliance will develop the communication, and once the material has been approved by the PTA's Project Communications Manager, distribute it.

Written notices will include, as a minimum:

- A description of relevant works
- The dates, times and durations of the relevant disruptions
- The expected impact of the works on private property or access
- Alternative access arrangements, and
- Project contact details including a manned out-of-hours mobile number located on-site, the METRONET telephone information line, social media accounts, and website.

11.1.4 Site Complaints

The construction team will be issued with referral cards for the project complaints phone line in the event that a member of the public approaches them while they are on site. Members of the public will then be recommended to ring the contact number and the process outlined in the Community Engagement and Stakeholder Interface Management Plan (LXR-ALUA-SM-PLN-00001) for complaint escalation commences.

12. Interface Management

The Project includes parallel path activities, multiple stakeholders, modifications to key infrastructure and critical tasks both on the project and with adjacent projects. Consequently, there will be a need to ensure that all interfaces and overlaps are identified, any risks are mitigated and responsibilities, along with authorities, are adequately defined. This will ensure that all work items progress in a timely, efficient manner. The interface focus aims are:

- To ensure the earliest possible identification of all Project internal and external interfaces
- To ensure that all parties to each interface agree how and when it will be successfully closed
- To monitor the status of interfaces, facilitate their closure and ensure that successful resolution is agreed and documented
- To ensure that adequate and appropriate communication is taking place, and
- To act as an escalation route for issues related to interface closure and ensure resolution of same.

Internal interface issues will be resolved at the lowest possible level to minimise bottlenecks. It is anticipated that each involved party will assign an interface co-ordinator who will be the single point of contact for their designated area of responsibility.

The external interface with stakeholders and projects such as the Byford, RSR and TCL projects will be resolved by the ADT Team as appropriate.

Escalation protocols and procedures will be developed and agreed between the Alliance and PTA, with pathways detailed as appropriate. Similar pathways will be clarified with external parties and included in the subcontract and purchase management suite of procedures.

Stakeholders such as those mentioned above and others such as Main Roads WA, utilities and service owners and local government authorities will be managed by the Stakeholder Interface Management Plan (SIMP) (LXR-ALUA-SM-PLN-00001) (SIMP). The SIMP contains the details of how the interfaces with these stakeholders are managed (i.e., regular meetings) and documented (i.e., the Stakeholder Interface Register).

12.1 Disruption to Perth's Public Transport Network

The Alliance will ensure that bus services continue to operate during construction. The frequency, routing, and the functionality of existing public transport infrastructure affected by the Works will be maintained or replicated during the delivery of the works unless otherwise agreed with Transperth.

The Alliance understands the importance of the numerous bus routes that service the stations associated with this project with all efforts made to maintain the current level of service is maintained and the expectations of the passengers are met.

The Alliance will coordinate with Transperth in relation to the arrangement of replacement services in the event that the works require planned route closures such as the erection of new bridge beams over the numerous roadways and the closure of bussing facilities as the works progress. Full closure of roads or detours during construction affecting scheduled bus services will be avoided where possible.

Where road closures or detours are required, they will be minimised and localised to preserve route integrity and excessive variance to travel times. Any proposed road changes, route alterations and temporary bus stops will be agreed with Transperth prior to the commencement of the relevant works.

The Alliance will ensure that bus stops impacted by the Works will be replicated where necessary to provide capacity, accessibility and functionality to support patronage levels and pedestrian movements forecast for the

delivery the works, and that any temporary bus infrastructure remains operable and maintainable over its Lifecycle.

The Alliance will coordinate with the PTA in the event that traffic management will require planned cancellations or line closures.

12.2 Adjacent Property Access

The Alliance shall ensure that access to adjacent properties is not unreasonably impeded. Existing line of sight access will be maintained 24 hours per day.

Detail regarding the adjacent property access will be included within the Traffic and Transport Management Plan (TTMP). The specific Traffic Control Plans (TCP) will include the Traffic Guidance Schemes (TGS) to ensure construction activities impacting on access routes are managed and appropriate traffic control measures are implemented to ensure no physical barriers are blocking access to roads that lead to adjacent properties. Approved TCPs will become part for the overarching TTMP and added as an appendix as the approvals are completed.

Local residents and stakeholders to be engaged and consulted in accordance with the Stakeholder Interface Management Plan (SIMP) (LXR-ALUA-SM-PLN-00001) to ensure consideration is given to their access requirements for the duration of the works.

The Alliance shall ensure that there are no unplanned access disruptions to individual owners/occupiers and appropriate notification and consent shall be provided prior to any works commencing that could impact upon the level of amenity of adjacent properties.

Specifically, Department of Communities property access will be maintained throughout the completion of the second stage of bridge construction activities.

12.3 Advertising and Site Signs

The Alliance will erect project signage prior to the commencement of the works which comply with the PTA Project signs requirements at locations approved by the PTA's Representative. The sign will include:

- Alliance name
- Major subcontractors and consultant's names
- Other details as required by the PTA Representative
- Site access requirements
- Project contact details including site office address, and

If the above does not fit on a single sign then multiple signs will be erected.

The signs will be maintained in good condition until their removal three (3) months after Practical Completion.

No further advertising will be permitted by the Alliance other than names of manufacturers or names of owners on items of construction plant.

12.4 Impact to Bus Network

12.4.1 General

With the project located within a network of bus routes connecting the city and the train line itself with the Eastern suburbs of Perth; the consideration, management and disruption to these existing bus services has

been an important aspect to construction planning. The bus routes that service the train stations, access the bus interchanges, and utilise the existing level crossings associated with this project.

To facilitate construction of the intersection roadworks and the various rail infrastructure components at each intersection, some bus routes will need to carry out minor short-term detours while the works are being carried out, any changes to the bus routes will be communicated well in advance of the changes.

In addition, to enable access to complete construction of the ultimate rail alignment, the existing bus interchanges at Oats Street and Cannington train stations will need to be closed and temporary bus interchanges commissioned. Further detail on the two interchanges can be found in section 19 and will be communicated to all relevant stakeholders and the public as the details are finalised.

Although the position of these interchanges has been selected to minimise impact to the existing bus network, some minor long-term route detours will still be required. Impact to Road Network

With the project located amongst residential and industrial areas, linked to two bus interchanges and connected to a busy road network that continues either side of the rail alignment; the consideration, management and minimisation of disruption to their road users is of a high priority for the Alliance to both plan, and execute the works. The key locations and associated construction activities that require specific consideration for their impact on road traffic are listed in the table below.

TABLE 2: IMPACTS TO ROAD NETWORK FROM CONSTRUCTION ACTIVITIES

Project Location	Construction Activities
Mint Street/ Archer Street Intersection	Level crossing modifications, roadworks, crane access for structural installations
Carlisle Station Carpark	Carpark construction tie-ins to Bank Street, roadside bay construction to Rutland Ave
Oats Street Northern Carpark	Carpark construction tie-ins and roadside bay construction to Bank Street
Oats Street Intersection	Level crossing modifications, roadworks, crane access for structural installations
Oats Street Bus Interchange	Bus interchange and carpark construction tie-ins to Bank Street, roadside bay construction to Rutland Ave and Bank Street
Welshpool Road Intersection	Level crossing modifications, roadworks, crane access for structural installations
Hamilton Street Intersection	Level crossing modifications, roadworks, crane access for structural installations
Queens Park Station Carparks	Roadside bay construction to Sevenoaks Street, carpark construction tie-ins to Sevenoaks Street and Railway Parade
Wharf Street Intersection	Level crossing modifications, roadworks, crane access for structural installations
Cannington Bus Interchange and Carparks	Carpark construction tie-ins to Railway Parade, carpark and bus interchange construction tie-ins to Sevenoaks Street, roadworks to Railway Parade

To determine the best solution for minimising their impact to road users, the Alliance has reviewed each of these components of work in detail and explored various traffic phasing solutions to ensure all aspects have been considered. The key considerations were as follows:

- Traffic volumes and peak traffic times
- Priority direction for traffic flow (primary roads)
- Completion of works offline
- Access to local adjacent properties
- Access and continuation of PShP
- Working room and lane widths
- Working hours
- Methodology modifications for program acceleration, and
- Phased road closures and detours across the project.

The indicative methodology and phasing surrounding each component of works has been outlined within this plan and otherwise shown in the phasing diagrams provided in Appendix A. Detailed TCPs shall be developed when design is finalised and submitted to relevant stakeholders for approvals and any necessary public communication prior to works being undertaken.

12.4.2 Impact to PSP

With both existing and future Principal Shared Paths (PSPs) running the length of the project, the Alliance has assessed in detail the impacts to the PSPs during construction so that the disruption to PSP users can be minimised. The current PSPs are located to the North of the existing rail alignment commencing from Miller Street and finishing at William Street. Long term temporary adjustments will be made to the PSP infrastructure to maintain its operation until construction of its ultimate alignment. To ensure that PSP users will be able to continue to travel between Miller and William Street, the following situations will be implemented at various locations along its path:

- PSP to be maintained in its existing location wherever possible
- PSP to be diverted onto footpaths or onto the road with adequate bollard separation.
- PSP crossings to be closed and diverted to alternative crossing points
- Modifications made to intersections

The indicative realignment requirements for the PSP across the project can be seen in the access plan figures below, with the PSP diversions marked in magenta. The Alliance will endeavour to minimise changes to the existing alignment where possible to reduce PSP user diversions although some will be required to safely manage required construction activities, however priority will be directed to maintaining a functional PSP from its original start to finish (Miller Street to William Street).



FIGURE 39: PSP DIVERSION – MINT STREET

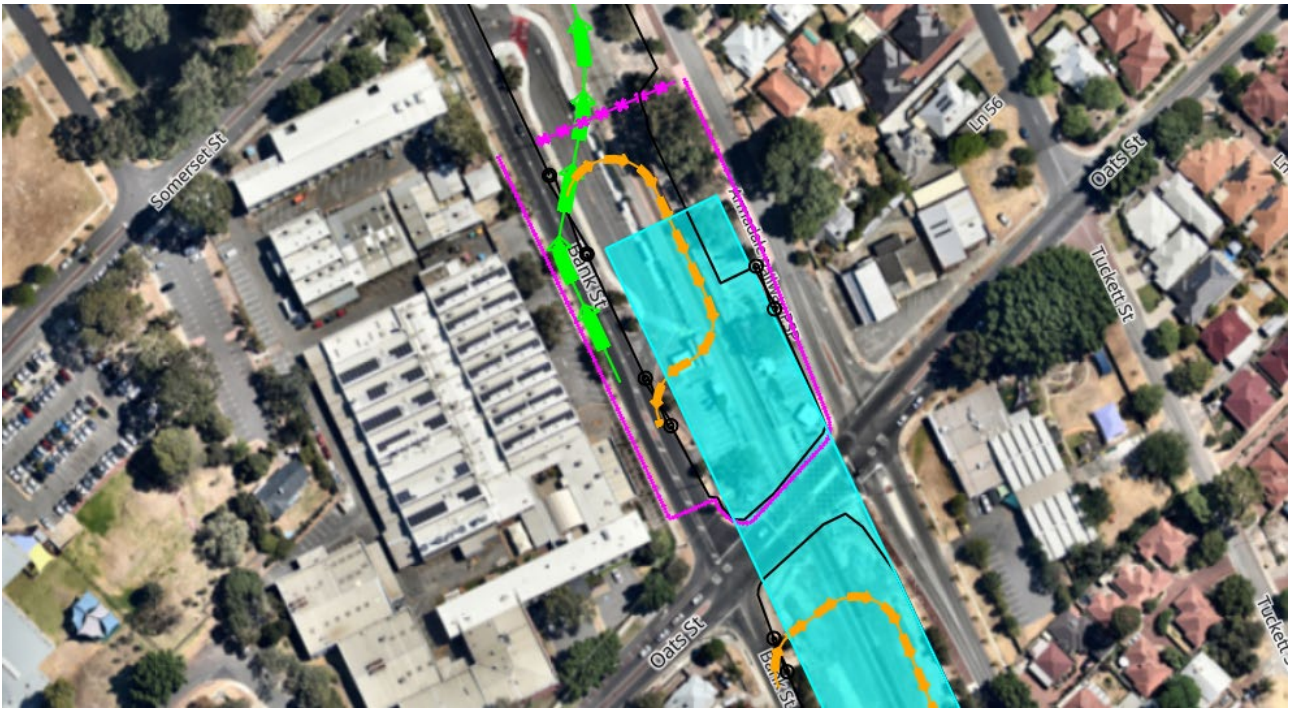

FIGURE 40: PSP DIVERSION – OATS STREET

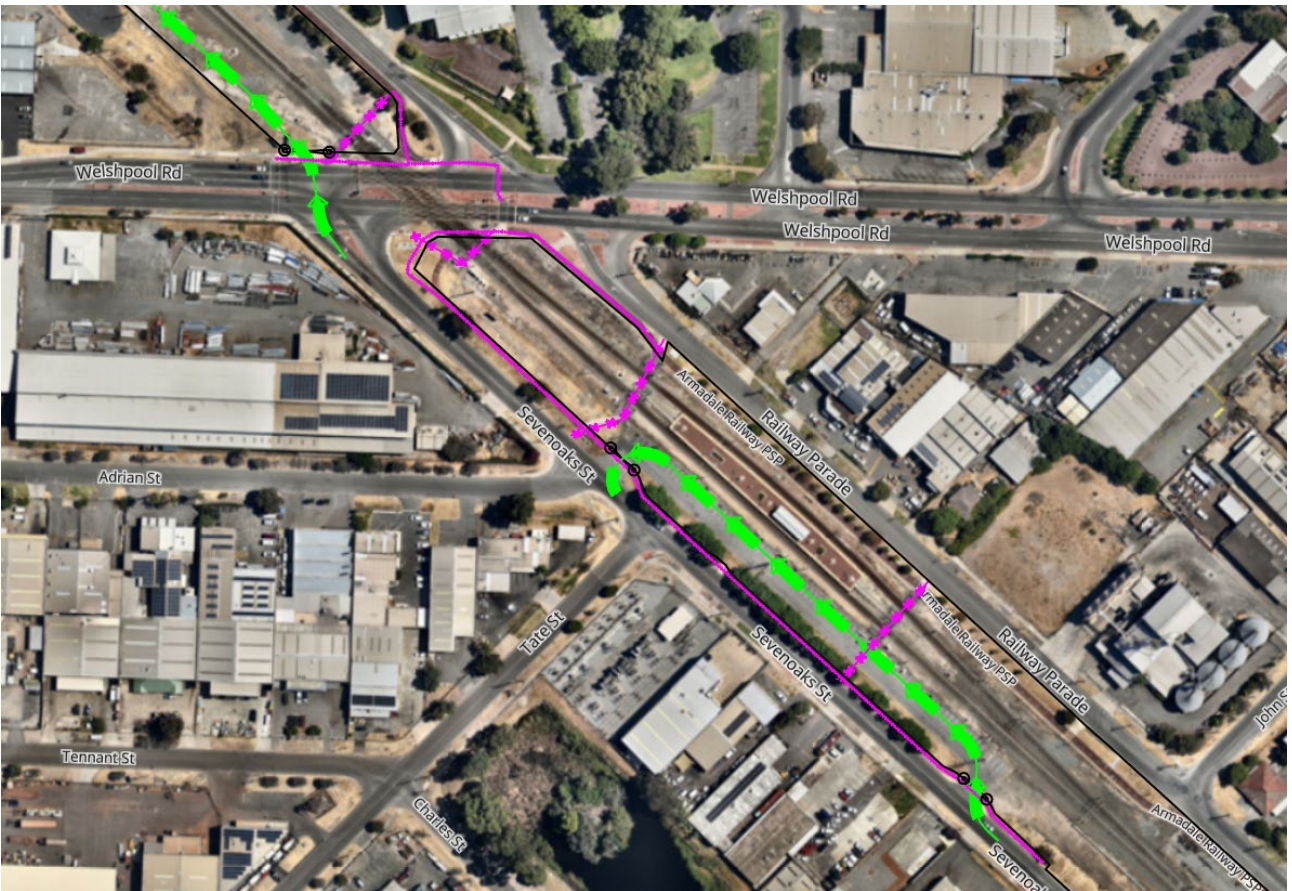

FIGURE 41: PSP DIVERSION – WELSHPOOL ROAD

OUR VALUES: MORAL COURAGE | RAISING THE BAR | PEOPLE AND FAMILY



FIGURE 42: PSP CROSSING CLOSURES TO BE DIVERTED TO WHARF STREET – NORTH



FIGURE 43: PSP CROSSING CLOSURES TO BE DIVERTED TO WHARF STREET – SOUTH

OUR VALUES: MORAL COURAGE | RAISING THE BAR | PEOPLE AND FAMILY



FIGURE 44: PSP DIVERSION – WILLIAM STREET

During the construction of each of the road intersections, the Alliance will also implement short term temporary PSP diversions through use of adjacent footpath infrastructure outside of the construction footprint, and with the aim to divert PSP traffic back onto the PSP as soon as possible after the intersection limits. The Alliance has decided to use existing footpaths as it reduces the need for additional construction (and later demolition), at the same time as providing an already established and safe travel path outside of the construction footprint. In addition, these diversions will only be implemented for several weeks and not for the duration of the project; already reducing their impact to PSP users. Detailed TCP’s will be developed and submitted for relevant approvals prior to work being undertaken.

- Mint / Archer Street
- Oats Street
- Welshpool Road
- Hamilton Street, and
- Wharf Street

12.4.3 Impact to Stakeholder interface

This Project runs in parallel with many adjacent MRWA / PTA / Western Power Projects which interface with multiple other stakeholders such as Government Authorities, Transport and Utility networks or local community groups. Consequently, there will to be a need to ensure that all interfaces and overlaps are identified, any risks are mitigated and responsibilities, along with authorities, are adequately defined. This will ensure that all work items progress in a timely, efficient manner. The interface focus aims are:

- To ensure the earliest possible identification of all Project internal and external interfaces
- To ensure that all parties to each interface agree how and when it will be successfully closed

OUR VALUES: MORAL COURAGE | RAISING THE BAR | PEOPLE AND FAMILY

- To monitor the status of interfaces, facilitate their closure and ensure that successful resolution is agreed and documented
- To ensure that adequate and appropriate communication is taking place, and
- To act as an escalation route for issues related to interface closure and ensure resolution of items.

Internal interface issues will be resolved at the lowest possible level to minimise bottlenecks. It is anticipated that each involved party will assign an interface co-ordinator who will be the single point of contact for their designated area of responsibility.

Escalation protocols and procedures will be developed and agreed between The Alliance and OMTID, with pathways detailed as appropriate. Similar pathways will be clarified with external parties and included in the sub-contract and purchase management suite of procedures.

Stakeholders such as those mentioned above and others such as MRWA, utilities and service owners and Local Government Authorities will be managed by the Stakeholder Interface Management Plan (LXR-ALUA-SM-PLN-00001) The Stakeholder Interface Management Plan (SIMP) contains the details of how the interfaces with these stakeholders are managed (i.e., regular meetings) and documented (i.e. Stakeholder Interface Register).

13. Services

13.1 General

Critical major services to avoid, protect or relocate during delivery of the project include:

- ATCO gas high pressure and medium pressure gas mains
- High and low voltage transmission and distribution Western Power lines
- Water Corporation water, drainage and sewer mains
- PTA Main Cable Route (MCR)
- Telstra, NBN, Optus, Vocus, NextGen and Western Power communication lines
- Town of Victoria Park, City of Canning and City of Gosnells stormwater network and water reticulation.

In addition, new and upgraded utility connections are required for the rail stations, public precincts, carparks, railway communications and to supply lighting for the Principal Shared Path (PShP).

The Alliance will provide a Utilities and Services Team to:

- Locate all services within the project footprint
- Engage asset owners to design and construct relocation of assets where required
- Engage asset owners and where required design and/or construct all new and upgraded utility connections for stations, traction power and other assets
- Provide effective management of service and utility relocations by Third Parties and the Alliance
- Construct the Water Corporation assets that require relocation or extension
- Design and construct any protection work for utilities and services not being relocated and any works required to protect railway infrastructure if services develop leaks in the future
- Ensure services that are remaining in place, both permanently and temporarily, are avoided and protected
- Remove or make safe by grouting redundant services in the Works area that have potential to impact on the Works under the Contract or existing assets, and
- If required engage asset owners and design and/or construct any additional services identified during the PAA that require relocation.

13.2 Owners of Utilities and Services in the Rail Corridor

A register of services within the area of the Works and corresponding drawings has been developed using the information provided, that includes:

- Service number
- Service type
- Service owner
- Likelihood of clash
- Potential scheduling impacts, and
- Need for asset or railway protection.

A schedule of contacts will be developed to enable effective communication with asset owners during the relocation of services. It will also be used for when works are being undertaken and notice is required to be provided to the asset owner. The Schedule will contain:

- The name of the asset owner
- A contact person, and
- Contact Details.

13.3 Avoiding and Protecting Utilities and Services

13.3.1 Avoiding

Prior to any excavation works, a Dial Before You Dig (DBYD) shall be completed to assess the area for known services, followed by non-destructive potholing to positively identify service locations and depths in accordance with AS5488.1. Services will be marked with a post or similar demarcation. If any critical assets are identified, the necessary permits to work around them will be obtained prior to works. A spotter will be in place for all mechanical excavation works.

Excavations around assets will be limited as per asset owner recommendations and guidelines. If permits or approvals are required from the asset owner, these will be obtained prior to excavation around these services. HV/HP or other specialised spotters will be engaged while carrying out excavation works. Where applicable, exclusion zones will be demarcated to prevent breaching, and all personnel inductions will include information pertaining to asset exclusion zones.

13.3.2 Emergency Response

Prior to commencing work on or near third party utilities, the Alliance will liaise with the relevant utility representatives to coordinate project emergency response requirements with the requirements of the third party in the event of a service strike.

In the case of a service strike, the work area will be evacuated, and the relevant Supervisor and Construction Manager will immediately be notified, as well as all relevant Stakeholders including PTA and the Asset Owner. Following the incident, an investigation process as outlined in the Safety Management Plan shall be followed.

13.3.3 Dial Before You Dig

A DBYD request will be submitted at the start of the project. The DBYD will be used in conjunction with other service investigation methods including Ground Penetrating Radar (GPR) and potholing.

The asset owners will be engaged to ensure they notify of any new or upgraded proposed service installations to the Services Manager during the project lifetime.

Proposed services will be checked prior to installation for clashes with the project works. The Services Manager will distribute the proposed service information to the relevant Alliance personnel.

For services not shown on DBYD such as railway infrastructure in rail reserve information will be sort from the PTA. This information will be sourced prior to any works are set to commence. Once all information is consolidated a risk assessment will be completed to identify if any further controls are required to be implemented to protect the services in the rail reserves.

13.3.4 Locating Existing Utilities and Services

Notification of potholing activities will be carried out in line with the asset owner’s specific recommendations as detailed in the “Approval to work near Service Assets” section below. Service locations will be performed by Approved Plant Location (APL) organisations.

Equipment used will include GPR, electronic cable locators. Vacuum and hand excavation equipment will be used for potholing to expose and measure the depth of a service. The vacuum equipment will be mounted on a light truck.

13.3.5 Standard of Location

In accordance with AS5488.1, the quality level we have in the information related to buried services will be classed as follows:

- Level A: confirmed 3D survey following potholing
- Level B: confirmed 2D surface location via non-intrusive methods such as Ground Penetrating Radar and Metal Detection. (Indicative depth will also be marked when available)
- Level C: information available from service authorities via the DBYD service
- Level D: services which have not been documented but are thought to exist based on site observation or anecdotal evidence.

13.3.6 Frequency of Location Works

Services will generally be located 2-dimensionally on the surface (Level B) at 5m intervals and 3-dimensionally (Level A by potholing) every 20m or closer spacing at changes in direction or intersection with other services. It may be necessary to pothole high impact services, such as high pressure gas, at more frequent intervals.

Where services cannot be located, the Alliance will advise the asset owner and seek on site assistance to locate or confirm the abandonment of the un-located service.

13.3.7 Colour Coding of Located Services

The Alliance will adopt the following colour codes for marking of services horizontally located on the surface of the ground with spray paint colour.

TABLE 3: UTILITIES AND SERVICES IDENTIFICATION

Service	Service Locator Colour
Electric Power Distribution and Transmission	Safety Red
Gas Distribution and Transmission, Oil Product Distribution and Transmission; Dangerous Materials, Product Lines High Visibility	Safety Yellow
Telephone and Telegraph System; Cable Television	Alert Orange
Fibre Optics Communication Lines	Alert Orange
Water Systems; Slurry Pipelines	Safety Precaution Blue
Sanitary Sewer Systems	Safety Green
Reclaimed or Non-Potable Water	Purple

13.3.8 Services Markers

Services located in 3-dimensions by potholing will have a 90mm PVC pipe inserted into the pothole. The bottom and top of the PVC pipe will be capped and the information about the service written inside the top cap. The PVC pipe will be cut such as the cap is level with the surrounding ground.

Where the pothole is situated in a footpath, a pipe will be installed with a cap no higher than the footpath surface. It will be surveyed as quickly as practicable following installation, then the footpath reinstated. At no time shall a pothole be left open and unprotected.

The naming system to be used for service identification has been developed in consultation with the APL's, the Project Survey Team, and the Project Design and Drafting Team. The aim is for all parts of the Alliance to use a common nomenclature to reduce the chances of misinterpretation of data as it is potholed, surveyed, and then modelled.

New service locations will be recorded by the Project Surveyor using GPS equipment. This information will be uploaded to the BIM on a weekly basis (as minimum).

13.3.9 Development and Maintenance of BIM Model

The Alliance Services Design Team will develop a BIM model of all existing services based on the location and survey works being carried out throughout the project duration.

This model will be based in 12D with the string/layer conventions set out in the Engineering Management Plan (LXR-ALUA-EA-PLN-00001).

The design team will then import the 12D information into a program called Navisworks Manager which will enable clash detection between various elements within the model. Where clashes are detected, the relevant service organisations will be consulted to determine a course of action to design around the clash.

The BIM model will be rendered in Navisworks Freedom and made available to the whole project team for use in construction planning and design coordination.

Through the life of the project, the BIM model will be maintained such that:

- When services are made redundant, they are shown as either abandoned or removed
- When designs are completed, they are shown on the model as designed
- When services are constructed, they are shown as installed.

It is important to note that as well as the services nominated by the service organisations, the BIM model will include information on all buried aspects of the project works, including but not limited to:

- Underground structures such as culverts and footings - Newly abandoned or redundant services
- Concrete encasements and sleeves.

13.3.10 Approval to work near Service Assets

The Alliance is required to carry out a notification procedure to service providers along the project site when approaching their respective assets. This section outlines the requirements from those service providers and the manner in which the Alliance will submit an application.

13.3.10.1 Water Corporation

The Water Corporation require notification to work near their pipelines at least five (5) working days before commencing work. All notifications must be made to a Technical Advisor and the contact number is 13 13 75. The Technical Advisor will determine whether a risk assessment is required before Works can commence.

Works conducted completely outside of the zones in Table 12 do not require a Water Corporation risk assessment.

TABLE 4: WATER CORPORATION NOTIFICATION ZONES

Asset in the Planned Work Area	Size	Contact Water Corporation if Ground Disturbing Work Involves
Water Main – All Materials	300mm diameter or greater	Working within 3m of the pipe centreline, or crossing under or over a pipe
Water Main - RC or AC	All sizes	Working within 2m of the pipe centreline, or crossing under or over a pipe
Sewerage Pressure Main	All sizes	Working within 3m of the pipe centreline, or crossing under or over a pipe
Drainage Pressure Main	All sizes	Working within 3m of the pipe centreline, or crossing under or over a pipe
Any Pressure Pipes	All sizes	Working near key infrastructure such as railways, freeways, bridges or similar extra caution required – be aware that damaged pressure pipes can undermine foundations and damage key infrastructure
For underground power installation: <ul style="list-style-type: none"> • Gravity sewers, junctions and risers • Drainage Pipes 	All Sizes	Crossing within 1m of a pipe wall, or excavating parallel within 0.5m of a pipe wall drainage pipe
All Assets	All sizes	For heavy vehicle crossings other than on established (i.e., permanent) roadways

13.3.10.2 ATCO Gas

ATCO Gas does not allow excavations within 15m of a high-pressure gas main without prior approval from ATCO Gas Australia. In addition to the 15m requirement, an Approved Locator must be on site to attend and assess all works and activities within 5m of a high-pressure gas main. In addition to the 15m and 5m requirements above, all digging within 1m of the high-pressure gas main must be by hand until the gas main is visually located and confirmed. When working over High Pressure gas mains the location of the main must be pegged or suitably visually indicated.

13.3.10.3 Western Power

Western Power require compliance with the following document for notifications when working near Western Power assets.

http://www.westernpower.com.au/documents/applicationforms/work_near_overhead_lines.pdf

The Alliance will comply with the following document for working distances for above and below ground power services.

<http://www.westernpower.com.au/documents/workpowerlines/guidelinesexcavationworksnearwesternpowers.pdf>

The Alliance will make contact with Western Powers' Customer Contact Centre on 13 10 87 where the risk assessment determines that the:

- Excavation work is within 3m of the electrical network and all or part of the electrical network is inside a collapsible area
- Plant or machinery may enter the Danger Zone when operated.

In addition, for transmission conductors, Western Power does not allow personnel, plant and material to encroach within the 6m danger zone around overheads. If it is not possible to manage the works to ensure no personnel, plant and material enters the 6m danger zone the Alliance Team must obtain an electrical permit from Western Power.

13.3.10.4 Telstra

The Alliance will contact Telstra before any site works begin to determine Telstra's requirements.

13.3.10.5 Optus

The Alliance will contact Optus before any site works begin to determine Optus' requirements.

13.3.10.6 Nextgen

The Alliance will contact Nextgen before any site works begin to determine Nextgen's requirements.

13.3.10.7 Local Government Authorities

The Alliance will contact Cities of Canning and Gosnells, and the Town of Victoria Park, before any site works begin to determine requirements of the LGA's.

13.3.10.8 PTA

Access to the railway for the purposes of conducting works is managed through a number of protocols including the contractual requirements of the Project Alliance Agreement and the PTA's procedures including (but not limited to) 8110-400-029 "Applying for Access to the PTA Operating Railway Reserve" and 9100-000-007 "Safeworking Rules and Procedures". These protocols will be followed by the Alliance and incorporated into delivery plans and programmes accordingly.

13.3.11 Embargos

Some asset owners impose embargos on working on or near their services at certain times. The standard embargo periods are generally Christmas/New Year and during special events. Other embargos may be imposed at short notice for other reasons, such as due to a failure somewhere remote from site which puts greater demand on the asset in the Alliance work area. The embargos are to be observed during this Project.

13.3.12 Controls and Permits

The Alliance will implement a detailed permit system for the project. For works regarding services, typically these include:

- Permit to Dig
- Confined Space Permit
- Hot Work Permit, and
- Vicinity Permit

13.4 Effective Management of Service and Utility Relocations

The Alliance will effectively manage service and utility relocations, including Third Parties by:

- Make contact with the requesting organisation
- Confirmation of works with the organisation – on site meeting if required
- Detailed design information, or survey of proposed works to be provided by the requesting organisation
- Confirmation that the requested works will not adversely impact the Alliance works, and
- Instruction to the requesting authority that the works may go ahead and any conditions which may apply.

13.5 Summary of Services and Utilities

Throughout the Project there are many services that are impacted by either the construction works and/or the permanent works. As detailed above the Alliance will manage the protection and relocation of these services as necessary. Below is a summary of the major affected services group by the asset owner:

13.5.1 ATCO Gas

ATCO Gas has three live services that cross the rail corridor within the Project boundary. These include both medium and high-pressure gas mains.

The Alliance has assessed each of these existing crossings and determined that only the 150mm medium pressure gas main crossing the rail at Ch 7785 requires relocation due to a clash with the abutment adjacent to Welshpool Rd. To ensure the relocation of the gas main at this location does not impact the critical path of the project a under track crossing sleeve for the relocated gas main will be installed during the planned rail shutdown required for the relocation of the MCR.

The remaining two gas mains crossing (Ch 8000 and Ch 8920) the rail corridor will be protected to ensure construction works does not damage them. The Alliance has requested ATCO to assess if the HP 150 Steel under the existing Welshpool Station (Ch 8000) needs to be relocated as it would potentially clash with the Ramp Retaining Walls.

Off the rail alignment there is a requirement to relocate the medium pressure gas pipework due to the pavement widening works on Hamilton Street. This relocation work will occur well in advance of the construction works on the road.

All other ATCO Gas services within the construction footprint will be protected to ensure they are not damaged during construction. ATCO is currently updating the impact assessment which will determine if any of these services to be protected will require relocation due to the impact of construction works and location of their assets in the future configurations.

13.5.2 Telstra

Telstra has undertaken an impact statement based on the concept design for the Project. Within this impact statement allowance has been made by Telstra to relocate every existing service that crosses the rail corridor. The Alliance has assessed the current tender design, the depth of and location of existing Telstra services and reduced the number of relocations that appear to be required.

There are several Telstra nine services crossing perpendicular below the rail reserve with some of them required to be relocated as per below:

At Ch. 5843 (Mint St) there is a Telstra Service crossing the rail alignment which is close to the viaduct pier and will be also affected by the road modifications.

At Ch. 7150 there is a Telstra Service Crossing the rail alignment that will clash with a viaduct pier. Final assessment of the impact will be determined by the relocation of this pier (to avoid clashing with Water Service).

At Ch. 7170 there is a Telstra Service Crossing the rail alignment that will clash with a viaduct pier. Originally there was not clash here but due to the relocation of the pier (to avoid clashing with Water Main) now this service will be affected and will require relocation.

At Ch. 7800 there is a Telstra Service Crossing the rail alignment that does not clash with any construction works but alignment will be modified to accommodate the relocation of the services at Ch. 7820.

At Ch. 7820 there is a Telstra Service Crossing the rail alignment that will clash with a viaduct pier. Relocation will be required as pier cannot be modified to avoid the clash.

At Ch. 8220 there is a Telstra Service Crossing the rail alignment which does not clash with the construction works. The Alliance proposes to keep and protect this service.

At Ch. 10110 there is a Telstra Crossing the rail alignment that clashes with the viaduct piers and will require relocation. Relocation of the pier will be investigated but does not seem likely as the service goes straight in the middle of the pier.

At Ch 10300 adjacent to Wharf Street there is a Telstra service crossing the rail alignment which is close to the location of the viaduct pier. The design of the piles and pile cap for this pier will be modified and the existing conduits will be protected to remove the need for relocation of this service. The protection detail will be developed and agreed on consultation with Telstra. If protection and design cannot be modified, then relocation of these services will be required.

At Ch. 11700 there is a Telstra Crossing the rail alignment but it does not clash with any construction element hence will be protected.

In addition to the above there are two Telstra services that require removal. These are the existing Telstra connections to Welshpool Station and Tractorama.

Outside the rail corridor there is Telstra service that requires modification. This service is in the verge of Mint St. The conduits and cables running under the railway line do not need modifications, however the pits on each side of the rail reserve will need to be shifted or made to be trafficable due to the pavement widening of the Mint Street intersections.

Several Telstra Services require modifications at the intersection of Hamilton St with Railway Parade and Sevenoaks St due to the road widening modifications. The affected services will be on both outside verges of Railway Parade and Sevenoaks St, the northern verge of Hamilton St (west of the rail), both verges of Hamilton St (east of the rail) and the infrastructure at the south eastern corner of the intersection of Sevenoaks St and Hamilton St.

And also there will be several Telstra Services modification at the intersection of Wharf St and Railway Parade and Sevenoaks St due to the road widening modifications. There will be a pit affected on the north eastern corner of intersection of Hamilton St and Railway Parade. Also another pit will be affected at the south western corner of Wharf St and Sevenoaks St.

All other Telstra services within the construction footprint will be protected to ensure they are not damaged during construction.

13.5.3 NBN

Similar to Telstra, NBN has undertaken an impact statement based on the concept design for the Project. Within this impact statement NBN has made similar allowances to Telstra in regard to relocation of existing services that crosses the rail corridor. Given most of the NBN cables are contained within Telstra conduits crossing the rail reserve the NBN services that have been assessed as being required to be shifted are in the same locations as the Telstra services described above. The Alliance will coordinate between NBN and Telstra to ensure the timing of the relocation of the NBN cables aligns with the relocation of the Telstra conduits.

13.5.4 Optus

Like Telstra and NBN, Optus has also undertaken an impact statement based on the concept design for the Project. There are only two Optus services within the Project footprint. Both of these cables are contained within Telstra conduits crossing the rail reserve. The Alliance will coordinate between Optus and Telstra to ensure the timing of the relocation of the Optus cables aligns with the relocation of the Telstra conduits.

13.5.5 Vocus

Vocus has two services that cross the rail corridor. One of them is at Ch 7367 and will only need protection during construction of the Project. The other Vocus service will require relocation. This service crosses the rail at Ch 7800 and runs in the PTA MCR conduit to Welshpool Station. This cable is used by PTA as a link to the Forrestfield Airport Link Project and must remain. Therefore, when the MCR is relocated into its temporary location, this cable will also be connected to the temporary MCR. Then when the MCR is shifted to its permanent location on the viaduct this cable will again be connected to the MCR to maintain its connection to the PTA system.

Vocus also used 6 cores of the PTA main optic fibre for the Armadale Line. The Alliance will liaise with Vocus in advance of any shutdowns of the cable when it is being relocated into the temporary and permanent MCR locations. This engagement will enable Vocus to plan and communicate the upcoming shutdown with their customers.

13.5.6 Western Power - Communications

There are five locations where Western Power communications services cross perpendicular to the rail corridor throughout the Project. Two of these services are impacted by the permanent works in the Project and will require relocation. The location of the two crossings are Ch 5860 and Ch 10330. The new service crossings will be installed immediately after the long-term shutdown commences. The crossing to be protected are located at Ch 6630, Ch 6660 Ch 10370.

13.5.7 NextGen

Two NextGen optic fibre cables cross the rail corridor in the Western power conduits at Ch5860 and Ch 10370. Once the Western Power conduits are relocated the new NextGen optic fibre cables can be installed in the conduits. The Alliance will coordinate between NextGen and Western Power to ensure the timing of the relocation of the NextGen cables aligns with the relocation of the Western Power conduits.

13.5.8 Western Power - Transmission

The Western Power 132kV transmission lines along the edge of the rail corridor between Miller Street and Oats Street will be relocated by PTA for the project. The Alliance will coordinate all preliminary activities within this section of the rail corridor prior to the relocation to ensure no disruption is caused to the relocation works. It is critical that the nominated dates for the relocation are achieved as the construction program is driven by these set dates.

The Western Power 66kV transmission lines along the edge of the rail corridor between Oats Street and William Street will be relocated by PTA for the project. The Alliance will coordinate all preliminary activities within this section of the rail corridor prior to the relocation to ensure no disruption is caused to the relocation works. It is critical that the nominated dates for the relocation are achieved as the construction program is driven by these set dates.

13.5.9 Western Power - Distribution

There are numerous Western Power underground distribution services crossing the rail corridor. Only two of these existing services have been identified as needing relocation due to clashes with pier foundations at Ch 11900 and with the abutment foundation at Ch 12280. Both of these services will require relocation.

The new service crossings will be installed immediately after the long-term shutdown commences and prior to the piling activities commencing in the area.

Outside the rail corridor there is a requirement for the relocation of existing overhead power lines at Mint St, Hamilton Street, Wharf Street and William St. These relocations are required due to clashes between overhead power poles and the new pavement widening areas at the new intersections on these cross streets. Where these clashes occur the existing overhead power lines will be relocated underground.

The relocations at these intersections will be planned to ensure there are all completed prior to the new roadways commencing in each of the areas.

13.5.10 Water Corporation - Water

There are four water crossing under the rail corridor. Three of them will be relocated and the other will be protected.

At Ch 5980 there is a 100 CI water main crossing the rail which will require relocation due to it is in close proximity to a pier. The Alliance proposes to protect the service but due to its age relocation will likely be required.

At Ch 6940 there is a 100 CI water main crossing the rail which will require relocation due to it is in close proximity to a pier. The Alliance proposes to protect the service but due to its age relocation will likely be required.

At Ch 7155 there is a 610mm water main crossing the rail which will require relocation due to its clashing with the pier location. The new service crossing will be installed immediately after the long-term shutdown commences and prior to the piling activities commencing in the area.

At Ch 10846 there is a 1065 ST water main crossing the rail and in close proximity to the piers. The Alliance will move the pier locations to maximise distance to the service and enable it to remain with protective measures during construction.

Outside the rail corridor the existing water mains in the verge of Hamilton Street will need to be relocated to accommodate the pavement widening of the street and intersections. This relocation will be undertaken prior road upgrading works.

13.5.11 Water Corporation - Sewer

The Water Corporation sewer pipes crossing the rail corridor will not require relocation. Where necessary, protection of the existing pipes will be undertaken to ensure they are not damaged during construction.

The existing sewer pipes in the verge of Hamilton Street will need to be relocated to accommodate the pavement widening of the street and intersections. This relocation will be undertaken prior to the roadworks commencing in the area.

13.5.12 Water Corporation – Drainage

There are five drainage pipes crossing the rail corridor. Two of them will most likely require relocation (pending assessment by Water Corporation) and all the others protection.

At Ch 5860 there is a 375 Steel pressure drain crossing the rail which will require relocation due to it is in close proximity to a pier.

At Ch 6713 there is a 750 RCP drain crossing the rail which will require relocation due to it is in close proximity to a pier.

Worth mention that at Ch 10620 there is a 1050 drain crossing the rail under Cannington Station which is in close proximity to a pier. The Alliance will move the pier locations to maximise distance to the service and enable protection works only.

Additionally there is another service outside of the rail that will require protection.

14. Logistics

The Alliance will obtain all approvals and permits related to site access, establishment, haulage, stockpiling of materials and spoil management necessary to carry out the Works effectively, from the relevant Government Agencies including the PTA. Applications for approvals and permits will be made in a timely manner, with oversize permit applications to be made at least 30 days prior to the proposed date of movement.

The Alliance will carry out any Temporary Works or permanent enabling Works, as agreed between the Alliance and the relevant Government Agency, which are deemed intrinsic to such approvals or permits being granted.

The Alliance will allow for uninterrupted access for all emergency vehicles into the Construction Site at all times.

The Alliance will liaise with the relevant Government Agencies and establish requirements in regard to the Works. The Alliance will provide the PTA's Representative with the appropriate approvals.

The Alliance will obtain approval of the routes for cartage of bulk quantities of materials to and from the Construction Site, including excavated material and delivery of concrete, reinforcement and other materials, from the relevant Government Agencies.

The Alliance will obtain all necessary transportation approvals and vehicle permits.

14.1 Traffic Management

The Alliance has developed an initial traffic management plan (Refer to Appendix B) for the project detailing how the transport network will be managed during construction works to minimise disruption and optimise safe movement for all modes of transport. It shall have further detailed TCPs developed by authorised RTM as the design is finalised and will be submitted to all relevant authorities and stakeholders for approval prior to implementing. Key objectives of the traffic management plan include:

- Public and workforce safety
- Minimising disruptions for all road users, including property access during construction
- Minimising disruptions for shared use path and cycleway users
- Re-phasing of existing traffic signals to provide safe site access points and haul routes
- Minimising construction traffic impacts on the transport network and adjacent land use
- Engaging stakeholders during development of worksite traffic management plans
- Ensuring clear and concise communication of all transport timing and network changes
- Developing positive stakeholder relationships
- Coordinating work fronts and sequence construction activities to minimise road user impacts
- Coordinating with other third party works and events, and
- Monitoring the transport network to allow rapid response to issues if they arise.

A Traffic engineer and supporting traffic supervisor will be embedded in the delivery team to consider and minimise transport network impacts within the construction methodology and activities. The traffic management team's key responsibilities include:

- Advising on construction methodology and coordinating work activities to minimise impact on the road network, including:
 - Minimising detour changes with preference for long-term detour routes as opposed to frequently changing detours
 - Using the arterial road network over local roads where possible for site vehicle movements
 - Avoiding the closure of roads during peak hour where possible.
- Engaging with key stakeholders and organisations on traffic management planning and design, including LGA, MRWA and PTA
- Working with the community and stakeholder engagement team to effectively communicate traffic impacts and mitigation strategies
- Liaising with authorities to identify other third-party works that may impact the project and coordinate works to minimise disruption to the wider road network, and
- Implementing specific mitigation practices which may include:
 - Traffic signal timing or phasing amendments
 - A coordinated VMS strategy
 - Real-time road network monitoring and action response plans
 - Bus stop / route amendments and proposed mitigation, and
 - Rail replacement bus routes that circumvent the disruption caused by occupation works.

14.2 Site layout

The project site has been geographically split into 5 work areas as shown in Figure . These 5 Zones have been outlined within the Cost Breakdown Structure and they have shaped the structure of ALUA's planning and programming. Each Zone contains different construction related access constraints and hence our planning and co-ordination of resourcing and shutdowns have been modelled accordingly. This has shaped an efficient delivery approach by ensuring that each area is managed according to its specific characteristics, maximising the independence of the areas, and allowing multiple work fronts to progress simultaneously to accelerate the program.

The four Work Areas are outlined as follows:

- Zone 1: Miller Street Bridge to Oats Street
- Zone 2: Oats Street to Leach Highway
- Zone 3: Leach Highway to Gerard Bridge
- Zone 4: Gerard Bridge to Crawford Street

Project Zoning

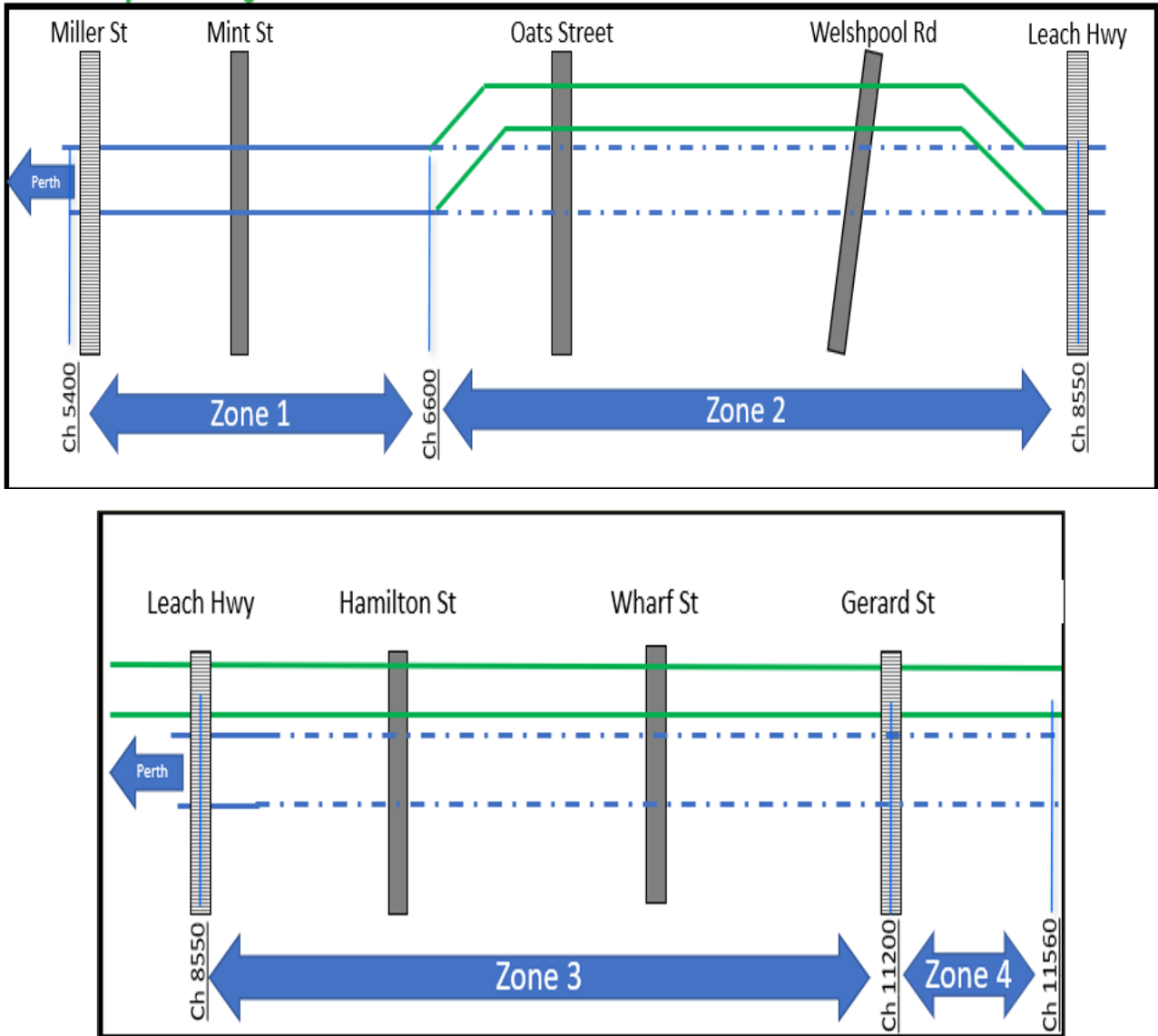

FIGURE 45: PROJECT SITE LAYOUT

14.3 Heavy haulage routes

Due to the restricted working area of the site, most of the large precast items will be delivered and installed in a 'just in time' arrangement. That is, the precast element will be transported from supplier's yard the same shift that it is required to be installed. Transport route arrangement is illustrated as below for the key elements.



FIGURE 5: TRAVEL FROM HUMES PRECAST YARD (L BEAMS)

1 Mint Street, 2 Oats Street, and 3 Welshpool Road

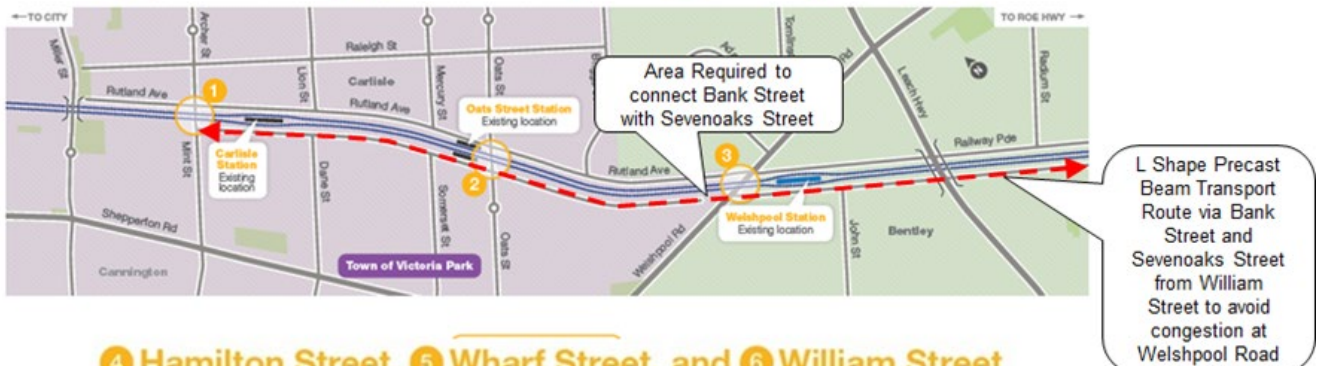

4 Hamilton Street, 5 Wharf Street, and 6 William Street



OUR VALUES: MORAL COURAGE | RAISING THE BAR | PEOPLE AND FAMILY

FIGURE 6: L-BEAM TRANSPORT WILLIAM STREET TO MINT STREET

Due to the weight and size of precast concrete element, it will be subject to MRWA travel restrictions and permit will be required.

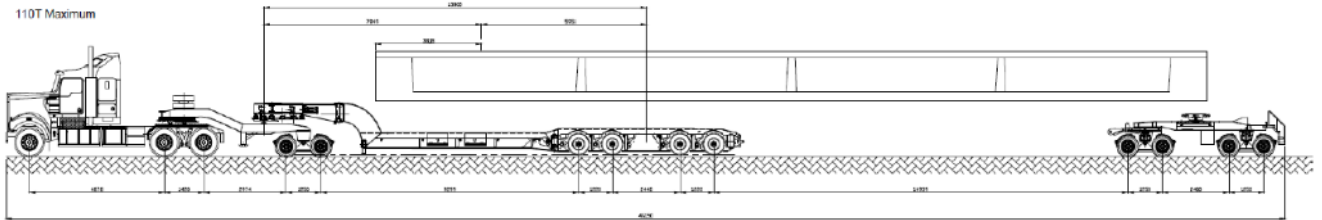

FIGURE 7: L-BEAM TRANSPORT ARRANGEMENT

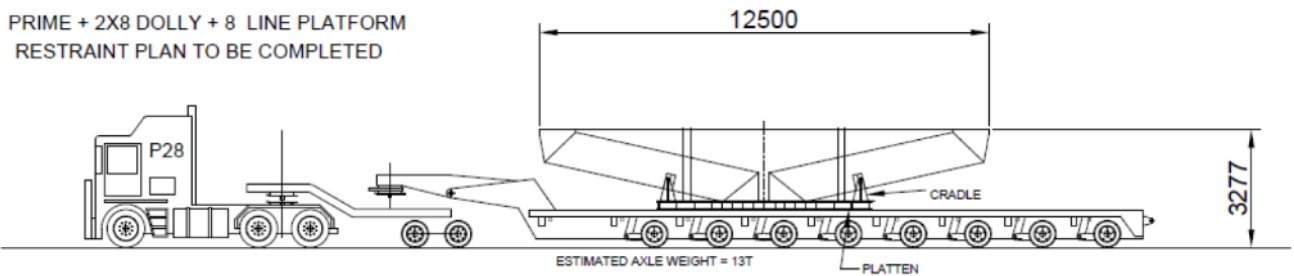

FIGURE 50: CROSSHEAD TRANSPORT ARRANGEMENT

These travel restrictions limit when precast element can be transported to site. Precast elements will approach the site from the north via Roe Highway, departing Roe and exit onto Welshpool Road then into William Street. They will enter the site via Sevenoaks Street and Bank Street. This will minimise disruption to the busy Welshpool Road level crossing.

In order to facilitate the early delivery and storage of L-Beams, enabling works along the haul routes need to be completed prior to the commencement of early deliveries.

In addition to the ground preparation, these enabling works include:

- Modification to existing William and Sevenoaks Street intersection and remove middle island, and
- Modification to end of Bank Street and connect Bank Street to Welshpool.

Due to the size of the precast package, there is a possibility that piers and crossheads maybe produced by an alternative supplier such as Humes. In the event that this eventuates a revised route assessment will be made. ALUA’s project preference will be all precast site deliveries to via William St and then progress via Seven Oaks/Bank St to their final destination.

14.3.1 Route Assessment

Early engagement with specialist transport companies and traffic consultant STRADA has led to a development of comprehensive logistics plan. As part of this a preferred transport route has been identified that meets the minimum RAV network requirement. Furthermore, a comprehensive desktop followed by field verification of the route, confirms that the selected route will minimise any negative impact on road users and stakeholders.

14.3.2 Hours of Work

Specialised transport companies will not be allowed to travel during the MRWA oversized vehicle curfew that generally occurs between 6am and 9am and 3pm and 6pm. Due to the quantity of precast elements to be delivered, both day shift (Piers, crossheads & retaining wall panels) and night shift (Lbeams) will be utilised.

Truck and trailer combinations not exceeding 40m (combined) with 2 pilots will be allowed to travel during dayshift.

Truck and trailer combinations exceeding 40m (combined) with pilots will only be allowed to travel on night shift.

A maximum of two trucks may travel in convoy when accompanied by pilot of escort vehicles. When two SPV’s are travelling in convoy, the pilot and escort requirements any other conditions that are applicable to the larger of the two SPV’s, apply to both the pilot and escort vehicles must accompany both SPVs as though they were a single SPV. An SPV must not travel in convoy over any bridge. This will be applicable over Roe Hwy.

14.3.3 Intersection modifications

In order to improve access to the site, some minor improvements to the existing intersections may be required. A detailed TCP will submitted to relevant authorities prior to any modifications. The key benefits gained from potential modifications:

- Less congestion at entry.
- Improved safety due to reduced interaction with road traffic.
- Eliminates need to heavy vehicle reversing; and
- Improved swept path access (eliminate clashes).

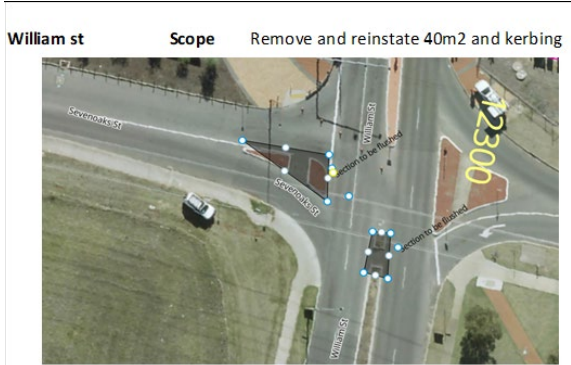

Ch 10550 **Scope** Remove and reinstate 120m2 and kerbing



Ch 10250 **Scope** Remove and reinstate 120m2 and kerbing



Ch 9900 **Scope** Remove and reinstate 120m2 and kerbing

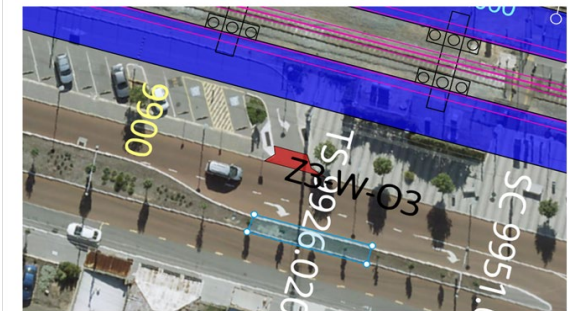

ch 9450 **Scope** Remove and reinstate 10m2 of nosing

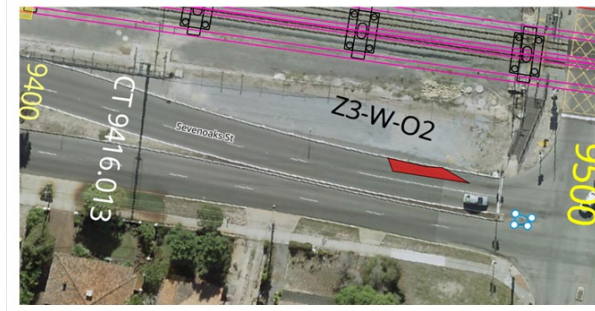

Ch 9150 **Scope** Remove and reinstate 120m2 and kerbing

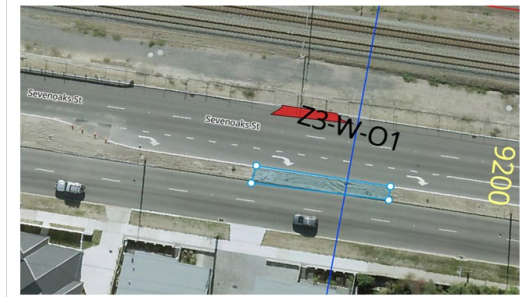

Welshpool rd intersection

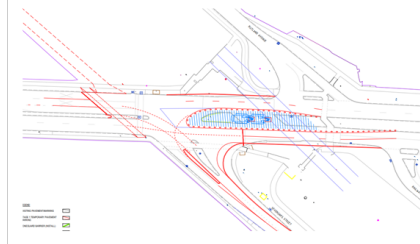

Scope

- Widen East bound
- Widen west bound
- Demo island
- Modify white lines
- Boreshot polymer line
- Undertake time in to Banks St
- Signal mods & white line mods
- Dismantle and reinstate white lines

FIGURE 51: INTERSECTION MODIFICATION TO ACCOMMODATE HEAVY HAULAGE

14.3.4 Swept Path Analysis

ALUA traffic design and Survey manager have undertaken extensive swept path analysis to ensure that trucks can make the appropriate turns. This will ensure that advance planning identifies intersection that will need to be modified. Refer below to Figure 52 for an example swept path analysis.



FIGURE 52: SWEPT PATH ANALYSIS AT WILLIAM ST SEVEN OAKS INTERSECTION

14.3.5 General Site Access

Site access has been configured to allow multiple access points for each subsection of works. The access track has been designed to be 7m wide and allows for single way traffic. Main advantage of single way traffic is that it allows for good visibility and prevents high risk activities such as reversing and conflicting traffic flow that has contributed to work accidents in the past.

Each access track will be provided with a suitable sized L beam laydown area.

Access gates have been made 12m wide to allow easy access to temporary construction track. Access tracks will be gated and served by a gate keeper to prevent access by general public.

The below sketch shows typical access track gate access.



FIGURE 53: TYPICAL TRACK ACCESS WITH ACCESS GATES

14.4 Site vehicle access

Given that the Project spans from Miller Street in Package 1 to Gerard Street in Package 2 the Project interfaces with many adjacent roads across 3 different Local Government Authorities. Hence the management of vehicle movements and deliveries including those by large truck are crucial to minimise disruption to the local community.

Access for construction plant and materials to the railway corridor using vehicles that are not oversized is readily achieved from Welshpool Road via distributor roads that lead to the railway corridor from the east, in addition to William Road from the west at Beckenham. Oversized vehicle movements are managed as described in this Section 17.

Package 1 and Package 2 is enclosed with Rutland Ave / Railway Parade on the East side and with Bank St / Sevenoaks on the West side. Hence, all Vehicle access points are stationed off these roads with sufficient set-back distances from the existing active level crossings. Section 17.3 outlines specified routes for which deliveries are to be directed to the various work locations around site. These routes will be constantly monitored to ensure compliance and to recognize areas where improvements can be made.

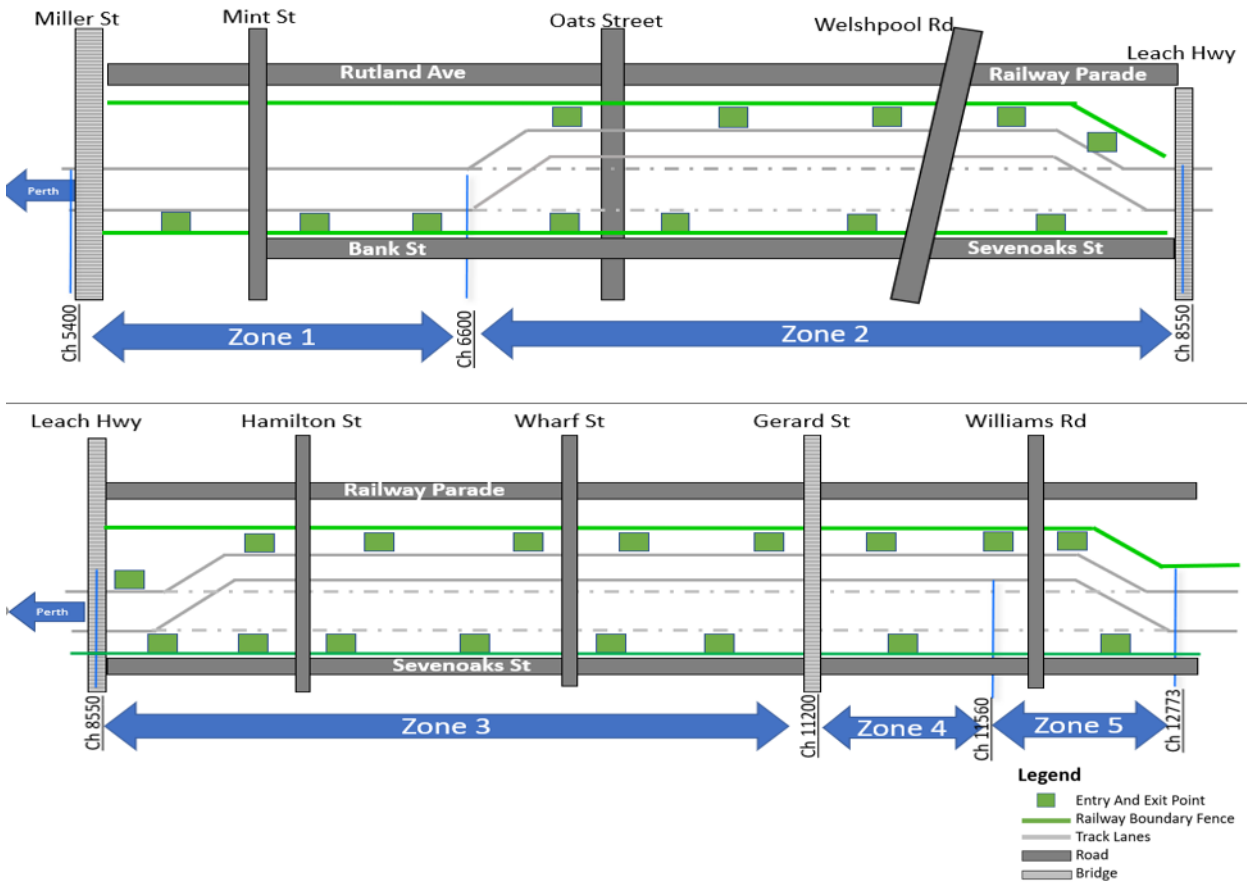

FIGURE 54: VEHICLE ACCESS POINT ALONG BANK STREET TEMPORARY PSP ALIGNMENT – PACKAGE 1

Each Access point and entry points have been designed in accordance with the Alliance Operational Minimum Requirements (OMR) 02 – Plant, Traffic and People and in accordance with the PTA Access Manual. The Alliance shall seek to utilise the existing PTA Access Points but also to install additional Access Points to align with our “Just in Time” logistic solution.

Each entry point will contain a Laydown Bay for large vehicle/trucks to station until the approval has been authorised to enter the site. The Laydown Bay shall allow the trucks to safely turn off the road will eliminate traffic congestion to build at each entry point. All Gates will have a Gateman to assist with site deliveries or alternatively the gate will be locked if the gate is not in use.

In compliance with the PTA Access Manual, access to the PTA operational assets will be maintained throughout the duration of the project. This will be achieved by:

- Maintaining current access points along Rutland Avenue, Railway Parade, Bank Street and Sevenoaks Street
- Linking project locks and PTA locks on access gates so PTA operations have access to site 24hrs per day, and
- Defining clear LV site tracks and pedestrian walkways to PTA operational assets within the project boundaries.

As the project progresses access to site will change. Any changes will be discussed with PTA representatives and once agreed, clearly communicated with the PTA organisation.

As work progresses specific details on how PTA are to access their operational assets will be developed and shared with PTA in the form of area plans or similar. The plans will clearly articulate the access provided enabling sharing with internal PTA shareholders and to be audited by the site team to ensure access is maintained.

14.5 Walkways

The Alliance shall ensure that all typical Public Walkway flows around the site are unimpeded throughout the Project duration where ever possible. The existing Walkways around the Project are generally situated on the opposite side of the surrounding streets and hence public disruption associated with Public Walkways will be minimal.

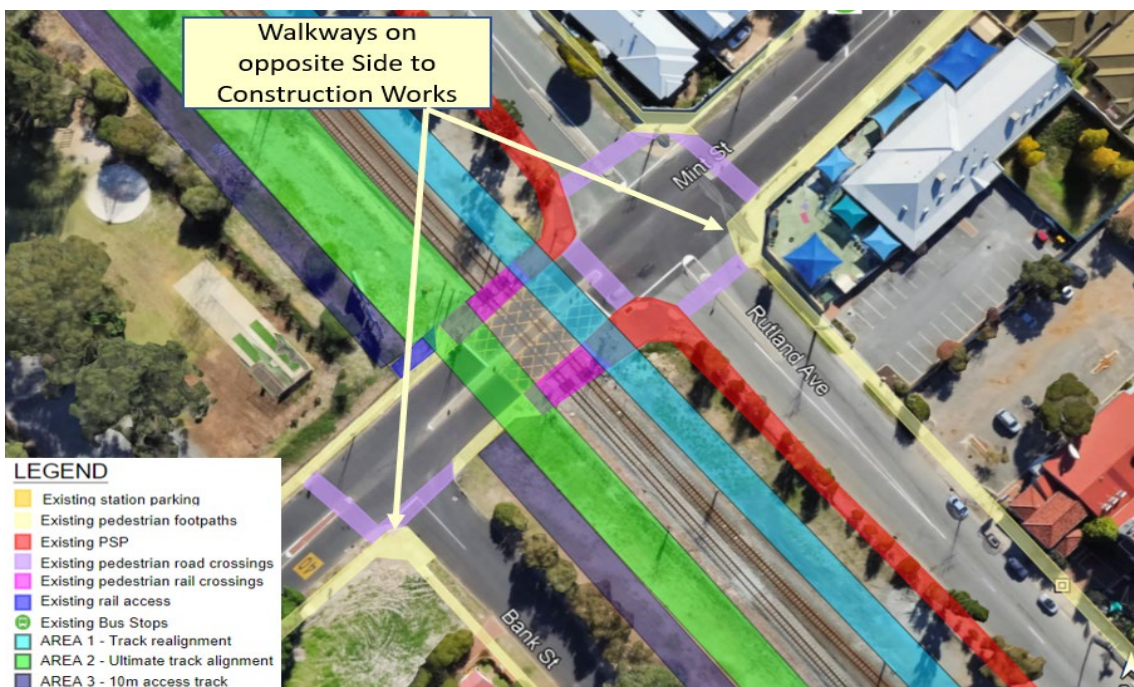

FIGURE 55: SAMPLE OF WALKWAYS TO BE MAINTAINED DURATION CONSTRUCTION- CARLISLE PACKAGE 1

The Alliance will implement the following control measures to keep pedestrians and vehicles apart at the construction workplace and when vehicles enter or exit the workplace:

- Providing separate traffic routes for pedestrians and vehicles, where possible
- Providing separate clearly marked pedestrian walkways for construction personnel that take a direct route
- Creating pedestrian's exclusion zones where powered mobile plant is operating
- Providing clearly signed and lit crossing points where construction pedestrian walkways cross roadways, so drivers and pedestrians can see each other clearly
- Scheduling work so vehicles, powered mobile plant and pedestrians are not in the area at the same time, and

- Where required install delineation between pedestrians and vehicles with type to be determined based on a risk assessment completed with each situation. Delineation include but not limited to flagging, windrows, crowd control fencing, temporary fencing, and concrete barriers.

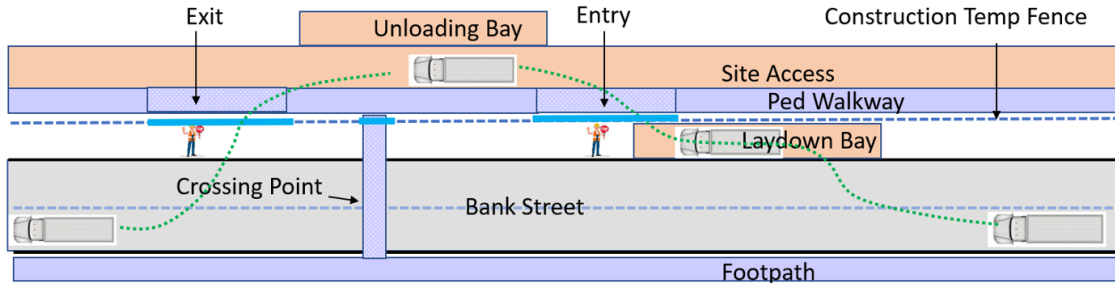

FIGURE 56: TYPICAL SITE ACCESS AND EGRESS DESIGNED IN ACCORDANCE WITH THE ALLIANCE OMRS.

Interface with the existing PSP is captured in more detail in section 15.5.9 of the Construction Management Plan.

14.6 Lighting plans

The Alliance shall provide lighting during the construction phase to ensure safe passage for both the public / patrons and our workforce. Temporary lighting shall be provided at the following temporary Carparks and Bus Interchange locations.

- Oats St Bus Interchange, and
- Cannington St Parking 1
- Cannington St Bus Interchange.

Emergency lighting will comply with:

- Section 2.7 of AS/NZS 3012:2010 Electrical installation – Construction and demolition sites including providing sufficient battery-powered lighting in stairways, passageways and next to switchboards
- AS 2293.1 -2018 Emergency lighting and exit signs for buildings – System design, installation and operation, and
- AS 2293.3-2018 Emergency lighting and exit signs for buildings – Emergency luminaires and exit signs.

14.7 Laydown area

The Alliance acknowledges the limited on-site Laydown Areas available and hence one of the key strategies associated Laydown Areas has been developed around optimising logistics to reduce the on-site requirements for Laydown areas. This strategy has been shaped by our founding concepts, such as

- Standardisation, Modularisation of key elements
- Fabrication off-site, Assembly off-site
- Just in-time delivery of major components, and
- Repeatability of construction process.

Whilst the strategy is to reduce site Laydown Areas it is not plausible to eliminate the requirement. Hence, the Alliance will utilise a combination of off-site and on-site laydowns for storage of materials and plant laydown.

To facilitate the Viaduct Construction a large Hardstand shall be constructed within the Rail Reserve which will be provided across the site for Track, Civil, Structures, Stations and Services activities. The Alliance will require on-site Laydown areas for the following

- Site Facilities for workforce (Cribs, Ablutions, Toilets etc).
- Laydown for Construction Materials
- Stockpile of Ballast, Sub Ballast Capping (SBC), General Fill
- Public Parking, and
- Transportation logistics.

TABLE 5: INDICATIVE PROPOSED OFF-SITE LAYDOWN AREAS AND LAND INTENT

Package	Potential Locations	Location	Land Use
Package 1	PL1	Miller & Betty Ave	Stockpile Excavation Material / Laydown
Package 1	PL2	Bank Street	Site Facilities / Parking / Laydown
Package 1	PL3	Bank Street	Site Facilities / Parking / Laydown
Package 1	PL4	Somerset street	Site Parking
Package 1	PL5	Bank street	Transport Logistics
Package 2	PL6	Mill St & Railway Parade	Stockpile Excavation Material / Laydown (Refer Figure)
Package 2	PL7	Cecil Ave	Site Parking / Site Facilities
Package 2	PL8	Gerard Street	Site Parking
Package 2	PL9	Bickley Rd	Stockpile Excavation Material / Laydown
Package 2	PL10	Bickley Rd	Stockpile Excavation Material / Laydown

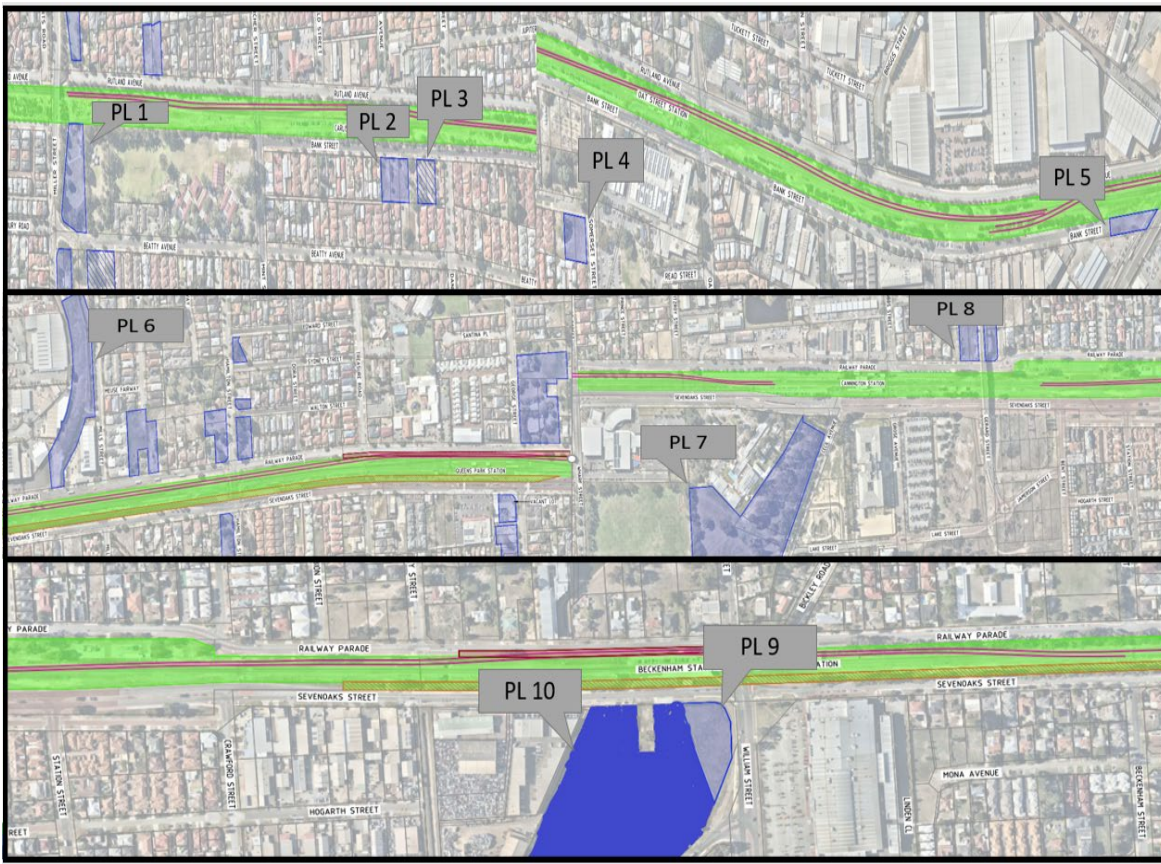

FIGURE 57: OVERVIEW OF PROJECT POTENTIAL OFF-SITE LAYDOWN AREAS

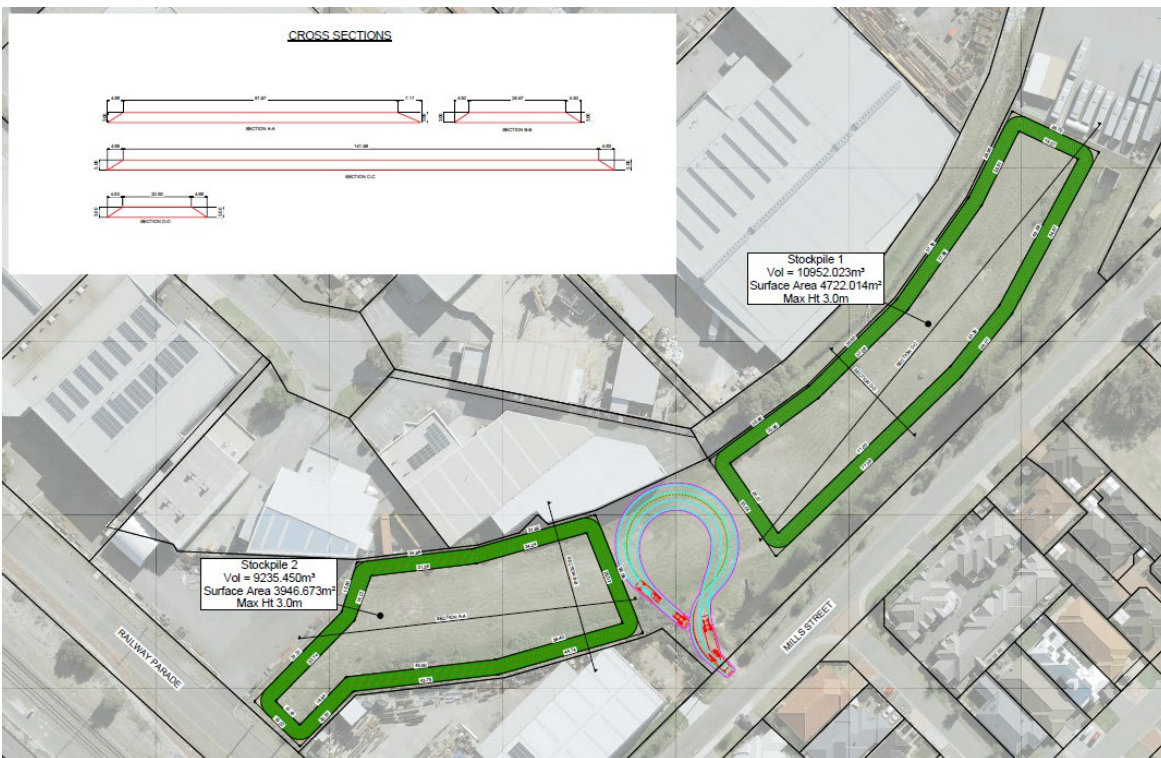

FIGURE 58: TYPICAL PROJECT OFF-SITE LAYDOWN AREAS – PL6

OUR VALUES: MORAL COURAGE | RAISING THE BAR | PEOPLE AND FAMILY

15. Staging

15.1 Project Approach

ALUA understands that any changes/impact to rail operations or rail systems configuration is crucial to the PTA. As a result, ALUA's staging philosophy has been developed to minimise disruption to the PTA network. Other factors such as reducing impact to the local stakeholders, community, bus networks and traffic flow has also been taken in consideration within ALUA's proposed staging of the works.

ALUA's delivery solution is based on a series of stages which captures key changes in the PTA's rail systems configurations within the limit of works. This approach ensures that specific attention is given to any systems & subsystems that are entered into service. Whereby each Entry into Service (EIS) event is not only crucial to running of PTA operations but also the successful delivery of the project.

It must also be noted that given that each Stage of the works is defined by a change in PTA's rail systems configuration, the completion of any given stage must be carried out under possession conditions of said rail systems.

ALUAs proposed staging is described below.

TABLE 6: (RAILWAY CLOSURE) STAGING

Stage	Description	Possession Type	Key EIS Event	Enables	Key Compliance
Stage 1	GE Fencing Install	ALBF Nights (8no)	Nil	GE fencing to facility MCR & offline works	<ul style="list-style-type: none"> Maintain existing MCR fibre connectivity within corridor
Stage 2	MCR UTX	Weekend	Track Recertification	OLE foundations and MCR underbore	<ul style="list-style-type: none"> Maintain existing MCR fibre connectivity within corridor
Stage 3	CAR & OATS Services UTX	Weekend	Track Recertification	OLE foundations and MCR underbore. Utilities UTX for CAR & OATS	<ul style="list-style-type: none"> Maintain existing MCR fibre connectivity within corridor
Stage 4	Temp MCR Cutover	Ext Nights (6no)	Track Rectification, MCR, Cooms/OT	MCR and Comms cutover project wide	<ul style="list-style-type: none"> Maintain existing MCR fibre connectivity within corridor
Stage 5	Victoria Park Turnback Commissioning	Weekend	Track Rectification, OLE, Cooms/OT, Signalling (TCS change)	Commission Vic Park Turnback signalling. OLE terminations	<ul style="list-style-type: none"> Maintain existing MCR fibre connectivity within corridor
Stage 6	Full Closure- Viaduct & Station construction	Full Closure (15 months)	Nil	Construction of Viaduct, Stations, abutments, & Rail System in "offline/greenfield" conditions	<ul style="list-style-type: none"> Maintain existing MCR fibre connectivity within corridor Viaduct & Station construction without live train interface Maintain Oats St and Cannington bus interchange facilities (i.e. bus stop, interchanges, driver amenities) as per temp schedule of accommodation
Stage 7	Victoria Park Decommissioning	Weekend	Track Rectification, OLE, Cooms/OT, Signalling (TCS change)	Perm rail system commissioning, Vic Park decommissioning	<ul style="list-style-type: none"> Maintain existing MCR fibre connectivity within corridor
Stage 8	Driver Training	Full Closure (12 weeks)	Nil	Driver training Commencement of fault free running FAA	<ul style="list-style-type: none"> Maintain existing MCR fibre connectivity within corridor Driver training (12 weeks) carried within 18-month closure duration Maintain Oats St and Cannington bus interchange facilities (i.e. bus stop, interchanges, driver amenities) as per temp schedule of accommodation
Stage 9	Follow up Tamp	Weekend	Track, Signalling and OLE recertification	Nil	<ul style="list-style-type: none"> Maintain rail services following works.

15.1.1 Precinct Phasing Principles

TABLE 7: STATION AND PRECINCT PHASING PRINCIPLES

Item	Principles
Access strategy	Minimise changes to pedestrian routes
Bus Interchange	Keep buses on existing routes
Impact to public and commuters	Signage, wayfinding, keep community well informed
Maintain user experience	Facilities at temporary bus stations (e.g. bike sheds, CSO office, public toilets)
Carparks	Provide adequate parking alternatives
Plant, people and traffic (OMR2)	Eliminate any interaction between construction works and the public
Temporary works (OMR5)	Robust design of TWs and sound process in place for ensuring adequate checks are being carried out on a regular basis

TABLE 8: STATION AND PRECINCT STAGING SEQUENCE OF WORKS (NOT APPLICABLE TO DA 1 PROVIDED AS OVERVIEW)

Phase	Activities
1	Works offline - temporary bus interchange and relevant facilities (Oats Street and Cannington)
2	Demolish existing stations (Carlisle, Oats Street, Welshpool, Queens Park, Cannington)
3	Removal of Level Crossings
4	Removal of existing rail infrastructure (tracks, ballast, etc)
5	Build Viaduct (piers, crosshead, viaduct girders, teeroff)
6	Construct station, access from both east and west sides
7	Construct hard and soft landscaping around the whole precinct
8	All stations EIS at the same time.

15.2 Road and Traffic Phasing (Not applicable will be covered under separate DA)

There are five major intersections of permanent roadworks modifications to be constructed on the project:

- Mint/ Archer Street level crossing
- Oats Street level crossing
- Welshpool Road level crossing
- Hamilton Street level crossing, and
- Wharf Street level crossing.

Further details of the phasing and traffic setup for these intersections are provided in Appendix A and will be covered in a separate DA for local roads and station precincts. Detailed TCP's submitted for relevant stakeholder notifications and approvals.

16. Construction Methodology

16.1 Overview

The Victoria Park to Canning Level Crossing Removal Project presents significant construction challenges due to the narrow brownfield corridor its situated in. The Alliance has undertaken extensive optioneering to develop a construction methodology and program that prioritises worker and community safety, accelerates project delivery and minimises community and commuter disruption while delivering value for money.

The key drivers for the delivery approach are:

- Minimising costs
- Minimising the overall construction period
- Minimising disruption to rail and road users
- Minimising construction disruption to the local community
- Minimising impact on property outside the existing rail property boundary
- Simplifying the viaduct structure design for cost and program efficiencies
- Understanding the site constraints to maximise construction efficiency,
- Minimising the risks associated with the occupation program strategy, and
- Understand the important key local community issues and work with them effectively.

The key constraints considered in the delivery approach are:

- Challenging design program to facilitate procurement and readiness for occupation works
- Statutory approval processes
- Proximity of private properties to the site
- Limited access points into site for over-dimensional loads
- Narrow corridor width for construction access
- Tie in with existing rail infrastructure that remains at grade
- Proximity of high voltage infrastructure
- Proximity of live rail infrastructure
- Traffic congestion on local roads (limiting road closure options)
- Limited laydown areas for materials, equipment and prefabricated elements immediately adjacent to site, and
- Heavy demand for construction related materials and services / escalating material and labour costs.

The key risks considered in the delivery approach are:

- Delay to design caused by stakeholders
- Ground conditions
- Inclement weather (particularly wind)

- Contamination
- Delay to statutory approvals
- Delay to critical service relocations & MCR relocations
- Unplanned disruption to rail services
- Delay in supply of occupation critical material (particularly precast elements)
- Market constraints (interest / plant / resources) on the delivery of large precast elements to site result in lower-than-expected production rates for crosshead and L-Beam installation, and
- Stakeholder constraints on the delivery of large precast elements to site result in lower-than-expected production rates for crosshead and L-Beam installation.

16.2 Statutory approvals

ALUA's construction methodology is aligned with its statutory approval's strategy, this includes the following considerations.

- DA approvals will be sought once the planning control area is declared and gazetted. The proposed approach is detailed in the DAMP and outlined below.
 - An early works DA will be submitted for viaduct piers and structure including piling and foundation works for the viaduct within station precincts. It will provide details on tree retention and removal strategy and enabling works such as service protection and relocation and other works within the PCA.
 - Station and station precincts including all the ground plane public realm, local roads, PShPs will be submitted as separate DA submissions for the relevant works with each LGA area.
- Building Permits will be submitted for each separate station and any TSO and miscellaneous buildings utilising a BCA consultant.
- Demolition Permits, will be submitted for each separate station, and
- Council Permits, all required council permits will be submitted as per the requirements of each LGA

16.3 Design interface

To mitigate the risk associated with a challenging design delivery program the Alliance will:

- Agree a baseline set of standards with stakeholders
- Assist OMTID/PTA in managing stakeholders' expectations around with SWTC requirements
- Weekly design / construction interface meetings to optimise the design for quality and ease of construction
- Undertake a value engineering process in parallel with the design gates
- Ensure that contractility review is incorporated at each design stage gate, and
- Regular workshops with key design stakeholders early in the process to allow parallel stakeholder input into the design process.

16.4 Civil and Services

16.4.1 Civil

This section describes the civil construction components, including the following:

- Accommodation works
- Temporary civil works
- Drainage
- Roadworks
- Carparks and bus interchanges
- MCR
- Rail Formation
- Lighting
- Principal Shared Path (PSP), and
- Landscaping.

16.4.2 Accommodation Works

The accommodation works encompasses all the minor enabling works such as

- Relocation of Rail Boundary Fencing, and GE Fencing Installation
- Establish Access and Egress Points East and West.
- Implementation of the Tree Retention Strategy including establishment of Tree Protection Zones (TPZ)
- Relocation of the Temporary PSP including lighting modifications, and
- Intersection and median modifications to support the construction works.

The accommodation works is essentially enabling works for the major package items such as Temporary Track Construction, Station or Viaduct Construction.

16.4.3 Relocation of Rail Boundary Fencing, and GE Fencing Installation

The Western Boundary fence shall be relocated further East to accommodate the construction works. A GE Fence shall be installed along the entire Rail Corridor to delineate the construction works on the West from the Live Rail on the East. Relocation of permanent Rail Fencing shall be performed in accordance with PTA Specification "8880-450-069.1.0.IFU Fences and Noise Walls".

The General Exclusion "GE" fence shall be installed at a minimum distance of 3m from the nearest live rail to delineate the general work zone from the live rail envelope. Activities that have a potential impact to rail operations or may encroach (temporarily or otherwise) beyond the vertical plane of the General Exclusion zone shall be classified as restricted activities, subject to further rigor, approval and controls i.e. shutdowns, possessions, de-energizations. The GE Fence shall be installed in accordance with PTA Specification "8185-100-001.1.0.IFU General Exemption (GE) Fence and Demarcation Partition".

16.4.4 Establish Access and Egress Points East and West.

Access and Egress Points will need to be established to allow construction plant, people, and materials to safely enter the Rail Reserve to perform their works. Access and Egress points shall be situated on the East and West Boundary of the Rail Reserve off Bank Street, Rutland Avenue, Seven oaks Street and Railway Parade. More details of Access and Egress has been provided under section 17 of the Construction Management Plan.

16.4.5 Implementation of the Tree Retention Strategy

Design and construction methods have been adapted to retain as many trees as possible. For example, the project will use gantry cranes, to significantly reduce the project's footprint. Trees removed will be replaced, transferred, or repurposed within the project site wherever possible (i.e.: within nature play areas or rewilding). Local governments have been consulted on the project's Tree Retention and Planting Strategy with consideration of their Urban Forrest Strategies and Tree Registers. A clearing permit system will be set up to ensure all clearing is within approved native clearing permit and relevant authorities and stakeholders are notified prior to clearing taking place or changes to the Tree Retention and Planting Strategy.

Trees that are to be afforded protection as per the tree management report shall be surveyed and protected as per the following.

- Provide a 2m radius tree protection zone (TPZ) through 1.8m high fencing.
- Fencing is not to be moved or removed at any period.
- Signage notifying people of the TPZ and other requirements placed on each side of the fencing.
- Any roots identified to be pruned should be pruned with a final cut to be undamaged wood outside of the TPZ. Pruning cuts should be made with sharp tools such as secateurs, pruners, handsaws or chainsaws. Pruning wounds should not be treated with dressings or paints. It is not acceptable for roots to be pruned with machinery such as backhoes or excavators.
- Any trees removed or significantly damaged as a result of this application should be replaced;
- All retained street tree(s) within the development site shall have measures consistent with AS 4970-2009 undertaken to ensure their protection during construction of the subject development

16.4.6 Temporary Civil Works

16.4.6.1 General

The Temporary Civil works are an essential part to ensure that the Transport Network remains operational throughout the construction works and that disruption to the Public is minimised.

Only Temporary Bus interchange works are required, given that a full rail closure will be in-place and hence no requirement to keep Rail, Stations and Carparks operational.

16.4.6.2 Temporary Bus Interchanges

There are two existing bus interchanges located along the Armadale train line within the project extents; the Oats Street station bus interchange and Cannington station bus interchange. Both are located within the project footprint and will clash with the future rail infrastructure. As such, the two future interchanges have been relocated in the design to different locations within the proximity of their corresponding ultimate train station precincts and will need to be removed prior to construction of the rail infrastructure at their location.

With a project priority focused on disruption minimisation to the existing bus network and its users, bus interchanges will be maintained at both Oats Street and Cannington stations throughout the duration of the works. To ensure this can be achieved, temporary bus interchanges will be constructed and commissioned prior to closure of the existing, and in use until completion of the ultimate.

The details and location of the Oats bus interchange temporary facility concept is being finalised and will be provided for relevant stakeholder review and approval once this has been finalised.



FIGURE 83: EXISTING CANNINGTON STATION BUS INTERCHANGE

The Alliance solution for the Cannington Station temporary bus interchange is to retain it as near as possible to its existing location. The closest most suitable plot identified is at 58 Cecil Avenue, so the Alliance is working with relevant government agencies to obtain this plot for the duration of the works.

Buses will only be able to access the bays when travelling South along Sevenoaks Street, as illustrated in the diagrams to follow. The Alliance selection criteria for this solution was based on the following:

- Eliminate the requirement for tree removal.
- Mitigate unnecessary extension of bus routes.
- Ensure bus passenger timetables are not impacted.
- Centrally locate the bus interchange to the temporary station and carparks
- Bus driver sightlines through the bus interchange
- Eliminate any impact to road users.
- Utilisation of roads already occupying bus services
- Minimise impact to local community/ property owners, and
- CEPTED assessments.

The minor route diversions required for certain bus services to access these temporary bays have been detailed in section 15.5.6. The temporary Cannington Station bus interchange will be constructed by

constructing roadside bays within the existing verge and making minor adjustments to the adjacent existing road infrastructure. These works will be carried out using the methodology and equipment as detailed for roadworks on the project.



FIGURE 84: LOCATION OF TEMPORARY CANNINGTON STATION BUS INTERCHANGE

16.4.7 Drainage

16.4.7.1 General

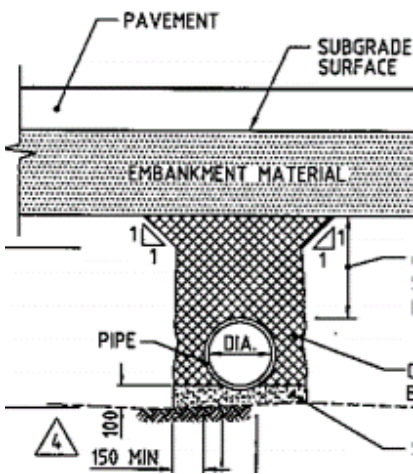

FIGURE 85: BACKFILL EXAMPLE CROSS-SECTION

The civil drainage construction can be categorised into the following types: installation of stormwater culverts, pits and end treatments, drainage basins, subsoil drainage to structures, rail formation drainage, temporary drainage, and the connection, removal and grouting to the existing drainage network.

Surveyors and service locators will be used to pick-up the existing drainage network as a component of the project service investigation/ location. In addition, surveyors will be used to set-out and record as-built levels and alignments of the ultimate drainage network progressively throughout delivery of the project.

Drainage components will be progressively delivered to the project based on the installation schedule. All components will be stored at the nearest site laydown area before being transported within the project boundary and placed adjacent to their ultimate destination just prior to installation. Deliveries to be made by self-unloading vehicles.

Along the alignment, the drainage located within the respective intersection footprints that require traffic control, will need to be phased with the construction and traffic phasing associated with each intersection so that disruptions to local road users are minimised. These intersections are as follows:

- Mint/Archer Level Crossing
- Oats St Level Crossing
- Welshpool Road Level Crossing
- Hamilton St Level Crossing, and

16.4.7.2 Drainage and Basin Construction

The project drainage and basin construction consist of the installation all temporary and permanent stormwater culverts, pits and end treatments, drainage basins, v-drains, subsoil drainage to structures and drainage to the rail formation. Their construction will be carried out as follows:

- Survey set-out and setup of laser level control
- Trench excavation and material removal
- Bedding placement and preparation
- Drainage component installation (bases, pits, culverts, pipes, drains, end treatments, etc.)
- Pit bases and culvert survey as-built pick-ups
- Backfill installation and compaction to drainage in maximum layers as specified by the design
- Install temporary steel covers to drainage pits
- Removal of temporary steel covers and installation of pit lids upon completion of pavement construction, and
- Final as-built pick-up of pit lids and grates.

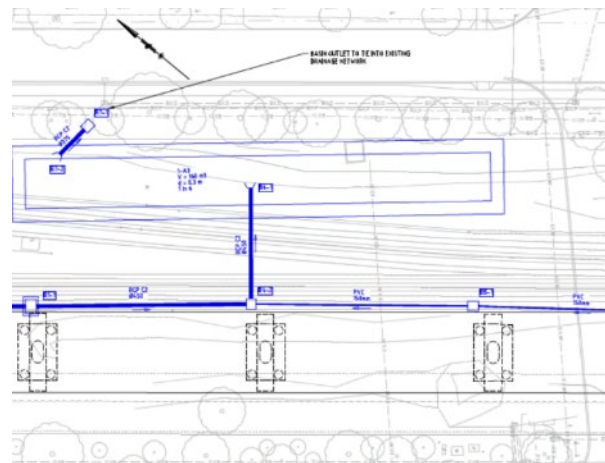

FIGURE 86: DRAINAGE BASIN EXAMPLE

With use of the following plant and equipment:

- Survey and levelling equipment
- Excavators, loaders, bobcats, dump trucks, concrete agitators, rollers, and
- Plate compactors, concrete vibrators, concrete saw.

16.4.7.3 Connection, Removal and Grouting to Existing Drainage Network

With the project footprint situated across existing infrastructure, and the new drainage is expected to connect to the existing network, a CCTV dilapidation report will need to be carried out on the existing drainage within the area in addition to their location and survey pick-up. All data obtained will then need to be fed back into the design to ensure the planned works can be carried out.

Prior to connecting new drainage components to the existing network, existing drains will need to be cleaned out to ensure a sufficient connection can be made. This will be carried out using a vacuum truck and by hand where required.

Where specified in the design, existing stormwater drainage components may need to be located, excavated, removed and disposed off-site where they have been made redundant within the network. Attention will be given to ensure that existing components that are to remain shall be protected where possible and monitored

when adjacent construction and demolition activities are undertaken. Where redundant drainage cannot be removed due to restrictions on access to complete the works, the redundant section shall be capped and grouted in its existing position.

16.4.8 Roadworks (Not Applicable covered under separate DA)

16.4.9 Carparks and Bus Interchanges (Not Applicable covered under separate DA)

16.4.10 Main Cable Route (MCR)

The main cable route carries the trackside signalling, communications, and electrical services for the railway. ALUA have considered the requirements for MCR’s for both the temporary and permanent track arrangements.

16.4.10.1 MCR Requirements

16.4.10.1.1 MCR Requirements

As a full closure of the railway is planned and as such the requirements for the temporary MCR are greatly reduced as it is to allow for only fibre optic cable continuity. The scope of work for pit and pipe associated with the temporary signalling and communications arrangement is as per Table 17 with connections into the nearest pits at the termination points.

TABLE 9: TEMPORARY MCR ARRANGEMENTS

Section	CH Start	CH Finish	Length (m)
Temporary MCR for Fibre (UTX x 1)	5500	5800	300
Temporary MCR for Fibre (ULX Mint St)	5800	6150	350
Temporary MCR for Fibre (UTX x 1)	7400	7760	360
Temporary MCR for Fibre	7950	8350	400
Temporary MCR for Fibre (UTX x 2)	8700	9300	600
Temporary MCR for Fibre (UTX x 2)	9670	10130	460
Temporary MCR for Fibre (UTX x 2)	10660	11150	490

- Temp and Perm MCR to be constructed in accordance with PTA specifications
- Procurement of the following items
 - Concrete risers, bases, trafficable pit lids, labelling
 - PVP Conduits – Orange and White
 - Concrete U-trough with separators
 - U-trough lid - GRP
- Backfill Materials (Sand, Stab, GF, Concrete, Pavement and Surfacing, Paving)
- Scope includes construction/ installation of all MCR components including underbores, trenching, pits, pipes, bases, U-trough, lids, grates, labelling and pit accessories.
- Earthing and Bonding if required

- Excavator, loader, plate compactor, water cart to excavate, install and backfill MCR trenches, pits and pipes and U-trough.
- Provision for Safeworking resources – PO1, PRES required for the works.
- Scope includes break out /clean out of existing pits at tie-ins to existing MCR Pits.
- Working around existing Services (Key items – High Pressure Gas, Truck Main, WC Valve Station).
 - Service Protection, Service Relocation Works.

16.4.11 Formation

The Project consists of constructing 3 Elevated Viaducts Structures. Formation is required at grade between each Viaduct and for every Viaduct approach. The formation construction shall either consist of an embankment batter or alternatively it will be contained with pre-cast retaining L-walls, hence the scope of works can be categorised into two main sections;

- 1. Formation Construction – Batter (No Retaining Wall), and
- 2. Formation Construction – Embankment Retaining Wall.

Summary of the Formation Construction is provided in Table 18 below.

TABLE 10: FORMATION CONSTRUCTION AREAS AND STAGING

Area	Ch Start	Ch Finish	Staging
Viaduct 1			
Formation - Batter	5500	5650	Shutdown
Formation - Embankment Retaining	5650	5820	Off-line
Viaduct 1	5820	7240	Off-line
Formation - Embankment Retaining	7240	7440	Off-line
Formation - Batter	7440	7620	Off-line
Viaduct 2			
Formation - Embankment Retaining	7620	7800	Off-line
Viaduct 2	7800	8000	Off-line
Formation - Embankment Retaining	8000	8300	Off-line
Formation - Batter	8300	8650	Shutdown
Viaduct 3			
Formation - Batter	8650	8860	Shutdown
Formation - Embankment Retaining	8860	9200	Off-line
Viaduct 3	9200	11000	Off-line
Formation - Embankment Retaining	11000	11100	Off-line
Formation - Embankment Retaining	11100	11240	Shutdown
Formation - Batter	11240	11700	Off-line

The Bulk earthworks for the embankment will be constructed using conventional methods and built in accordance with the PTA Specification 8190-400-002 - Narrow Gauge Mainline Code of Practice Track & Civil Infrastructure. The Alliance seeks to maximise sustainability and re-use existing materials which will significantly reduce wasting and hence improving efficiency as a whole.

Key formation construction considerations are as follows.

- Access and Egress points to site and Traffic Management
- Impact to the local road network and Vehicle movements around site
- Pot-holing and Service Protection
- Works behind the 3m Danger Zone and around PTA Comms Rooms
- Earthworks Production Rate and Earthworks Fleet Size
- Access Dates, Staging and Mass Haul Balance
- Various methodologies options such as
 1. Conventional Earthworks
 2. Conveyor System for Retaining Backfill
 3. Plant Selection (Confined Areas, Restricted Access Widths)
- Re-use of existing site materials such as Ballast, SBC, Hardstand.
- Re-use of site Contaminated Materials such as Ballast and SBC from existing Tracks
- Select Backfill for Structures and compaction restrictions against Retaining Walls.
- Temporary Retaining Structure to maximise off-line construction and minimise construction during occupations (Bulka Bags, Wrapped Geo-fabric).
- Backfill to Retaining Wall (Outside on Railside during Occo)

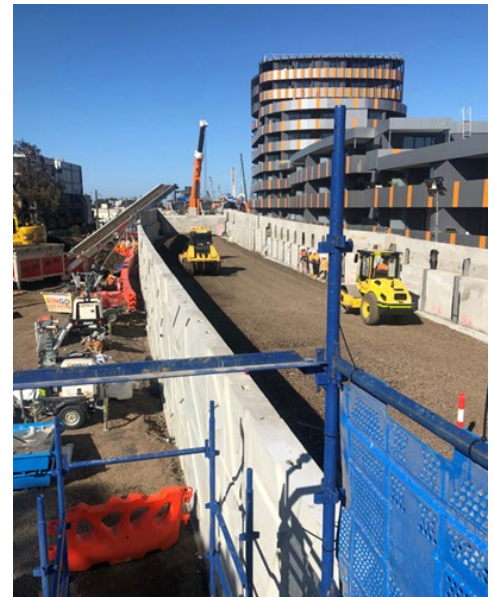

FIGURE 93: EARTHWORKS ACTIVITY

16.4.11.1 Formation Construction



FIGURE 94: GRADER AND ROLLER SPREADING AND COMPACTING CAPPING MATERIAL

Subbase material will be compacted to a minimum of 96% of modified maximum dry density when tested.

Approved limestone used as the capping material shall comply with the PTA specification and be certified as to being acceptable prior to be imported onto site.

It will be spread the full boxed out track width using a grader along the length of the formation and initially compacted with a smooth drum roller.

The formation capping layer will be compacted in layers not less than 100mm and not more than 210mm. The capping layer will have a thickness of not less than 230 mm. The source material for the supply of crushed limestone will be free of organic material, clay lumps, cap rock or any other foreign material deleterious to ensure its performance in the pavement.

Formation material will be compacted to a minimum of 98% of modified maximum dry density when tested.

16.4.12 Civil Lighting and Electrical (Not Applicable covered under separate DA submission)

16.4.13 Principal Shared Path (PSP) (Not applicable covered under separate DA submission)

16.4.14 Landscaping (Not Applicable covered under separate DA submission)

16.5 Structures

16.5.1 Viaduct

16.5.1.1 Viaduct Lifting methodology

16.5.1.1.1 Overview

ALUA recognises that the viaduct lifting methodology utilised on the project will be a critical success factor given the inherent risk associated with heavy lifting. There are total of 887 precast elements (i.e. Lbeam, t-roffs, Crossheads & piers) associated with the viaduct. ALUA has assessed various lifting methodologies during the AD phase and has based its lifting strategy on the following methods:

- Gantry Crane Lifts
- Mobile crane (i.e., crawler or slew) Single lifts
- Mobile crane (i.e., crawler or slew) Dual lifts

Each lifting methodology has its advantages and limitations and will be assessed for each critical element being lifted into place. This assessment includes taking into account the following considerations:

- Impact on trees and vegetation
- Impact on live rail operations and OLE assets
- Impact on underground and overhead services
- Interaction with adjacent construction activities & obstructions
- Impact on local roads & traffic
- Passive loading onto adjacent permanent structures adjacent to the site
- Productivity output & crane capacity
- Availability of crane

To eliminate lifting failure and guarantee success around lifting, ALUAs Operation Minimum Requirements (OMR) No 4, Lifting Operations will be followed by ensuring:

- All lifting operations are planned, managed and conducted by a competent person, including the commissioning and decommissioning of cranes.
- Cranes and Lifting equipment are only to be used for the purpose for which they are designed to lift and within their rated capacity.
- Personnel involved in lifting operations must hold the relevant license and must be verified as competent.
- All lifting equipment and cranes must be regularly inspected, certified, tested and comply with current Australian Standards.
- An assessment of the ground conditions must be undertaken prior to set-up to assess the capability of the ground to withstand the loads and pressures imposed by the lifting equipment.

- Earthmoving equipment used for lifting must be specifically designed and certified for the purpose of lifting.
- Pre-operation daily checks as per the Original Equipment Manufacturer (OEM) requirements, must be undertaken. Any faults found and/or equipment that is defective or shows signs of excessive wear shall be tagged out and immediately reported.
- Controls shall be put in place to prevent inadvertent entry into the lifting zone. Barricades, signage or spotters shall be used as is deemed appropriate for the the level of risk.
- Loads must not be lifted or suspended over people.

16.5.1.1.2 Typical 24hr Cycle for Lifting with Gantry Crane

07:00 – 17:00 (1 Single Lift Every 90mins)

- 4 Pier Sections (2 Full Piers)
- 2 Crossheads



21:00- 05:00 (1 Dual Lift Every 2hrs)

- 4 L-beams

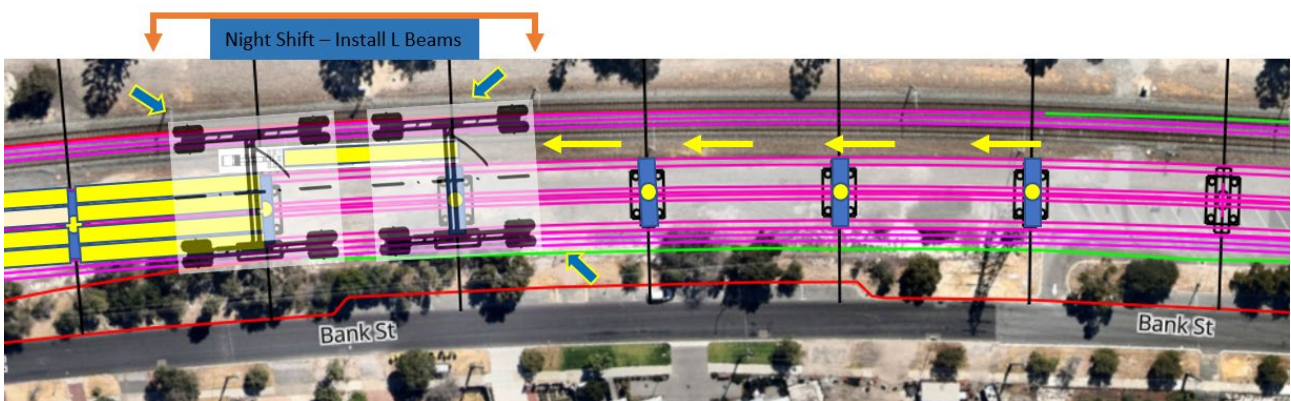

Lifting Methodology

07:00 – 13:00 (4 Single Lifts for Piers)

13:00 – 17:00 (2 Single Lifts for Crossheads)

Lifting Methodology



21:00- 05:00 (4 Dual Lifts for L-beams)

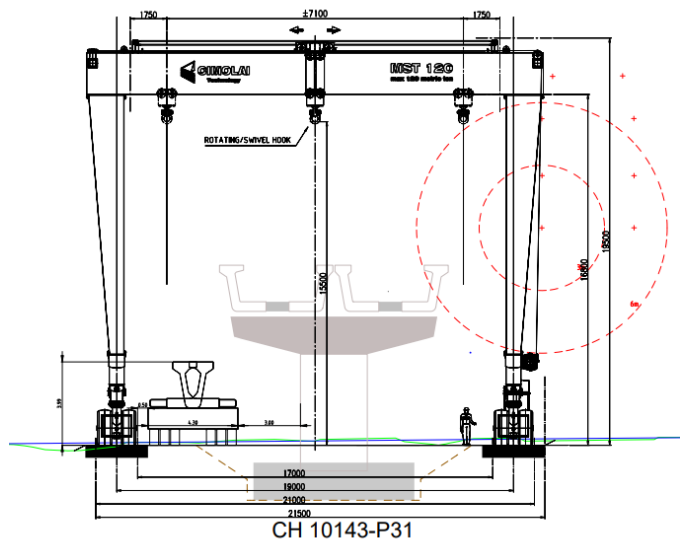
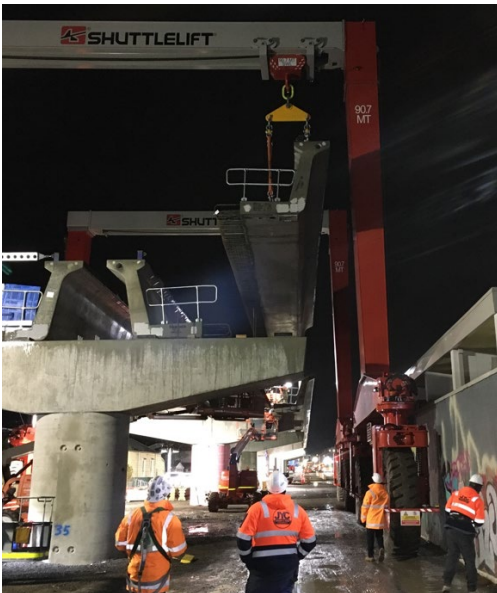

16.5.1.1.3

L beam lifting

Lifting Methodology	Benefits	Limitations
Gantry Crane Lift	<ul style="list-style-type: none"> ✓ Minimised footprint compared to mobile cranes, particularly in package 1 where there is a significant interface with mature trees along the corridor ✓ Increase productivity compared to mobile cranes ✓ Straddles worksite therefore allows for concurrent activities to continue ✓ Dual lifting hooks providing increase precision for landing beams within tolerances ✓ No set up/mobilisation time required for each change in lift location 	<ul style="list-style-type: none"> × Requires limestone running beam, therefore restricting work area × Unable to be used around station precinct due to width of portal crossheads × Unable to be used at road crossings
Mobile crane Dual lift	<ul style="list-style-type: none"> ✓ Provide flexibility around stations ✓ Suitable for lifting at road crossings without impacting road surface 	<ul style="list-style-type: none"> × Crane needs to be “de-kitted” (i.e., removal of counterweights to facilitate movement to new lift location resulting in loss productivity × Crane requires significant support crew (i.e., frannas for handling counterweights, bog mats etc) & counterweight trucks

Proposed usage throughout project

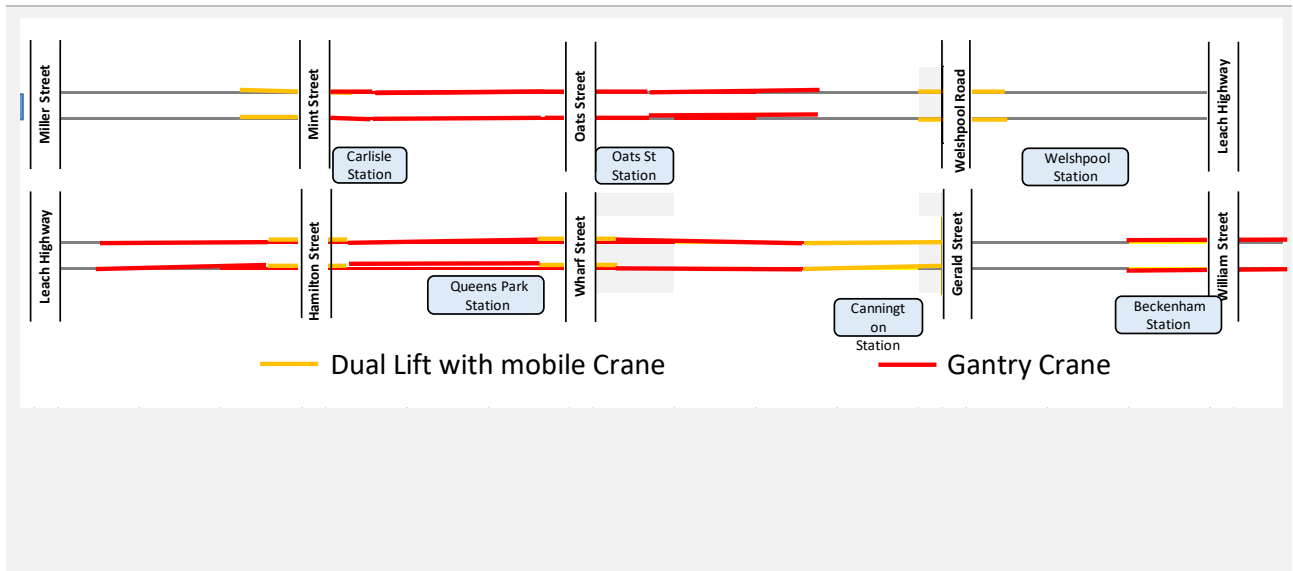

Gantry Crane L-beam lifts

Mobile crane Dual lift	<ul style="list-style-type: none"> ✓ Provide flexibility around stations due to width of portal Crossheads ✓ Dual lift allow flexibility of using smaller crane hence reduce singular crane footprint ✓ Dual lifting hooks providing increase precision for landing beams within tolerances 	<ul style="list-style-type: none"> × Crane needs to be “de-kitted” (i.e. removal of counterweights to facilitate movement to new lift location resulting in loss productivity × Crane requires significant support crew (i.e. frannas
-------------------------------	--	---

Lifting Methodology	Benefits	Limitations
---------------------	----------	-------------

for handling counterweights, bog mats etc) & counterweight trucks

Proposed usage throughout project

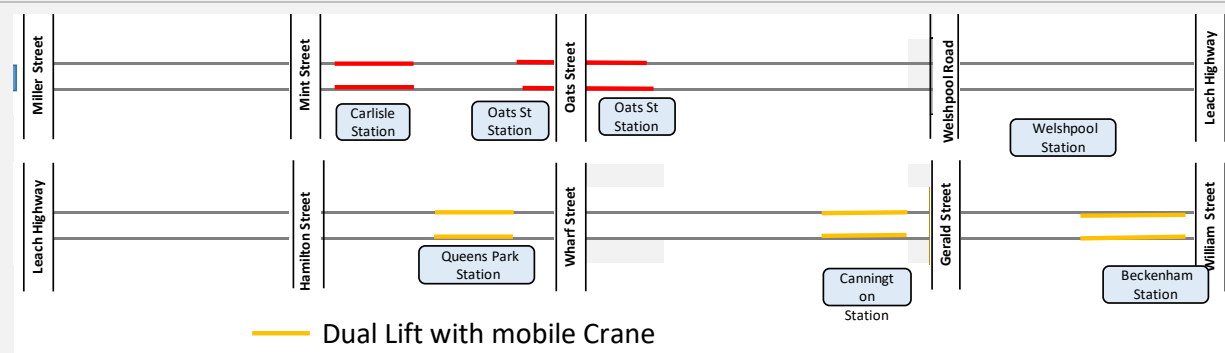

Dual Crane lifts

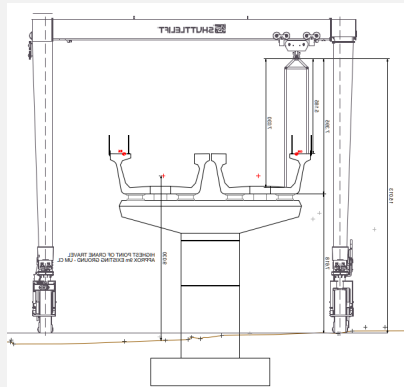
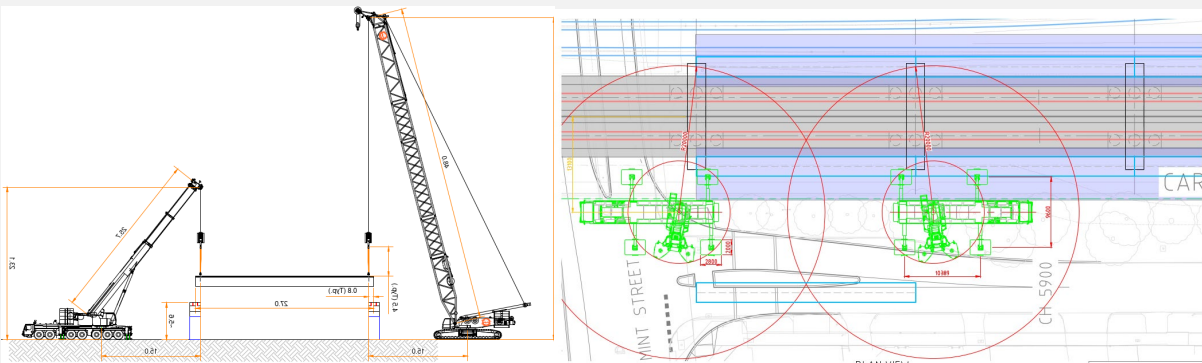

Dual Crane Lbeam lifts

Lifting Methodology	Benefits	Limitations
		

16.5.1.1.4 T-Roffs lifting

Lifting Methodology	Benefits	Limitations
Gantry Crane Lift	<ul style="list-style-type: none"> ✓ Minimised footprint compared to mobile cranes, particularly in package 1 where there is a significant interface with mature trees along the corridor ✓ Increase productivity compared to mobile cranes ✓ Straddles worksite therefore allows for concurrent activities to continue ✓ Dual lifting hooks providing increase precision for landing beams within tolerances ✓ No set up/mobilisation time required for each change in lift location 	<ul style="list-style-type: none"> × Requires limestone running beam, therefore restricting work area × Unable to be used around station precinct due to width of portal crossheads × Unable to be used at road crossings
Mobile crane Dual lift	<ul style="list-style-type: none"> ✓ Provide flexibility around stations ✓ Suitable for lifting at road crossings without impacting road surface 	<ul style="list-style-type: none"> × Crane needs to be “de-kitted” (i.e. removal of counterweights to facilitate movement to new lift location resulting in loss productivity × Crane requires significant support crew (i.e., frannas for handling counterweights, bog mats etc) & counterweight trucks
Dual crane Dual lift	<ul style="list-style-type: none"> ✓ Provide flexibility around stations due to width of portal Crossheads ✓ Dual lift allow flexibility of using smaller crane hence reduce singular crane footprint ✓ Dual lifting hooks providing increase precision for landing beams within tolerances 	<ul style="list-style-type: none"> × Crane needs to be “de-kitted” (i.e., removal of counterweights to facilitate movement to new lift location resulting in loss productivity × Crane requires significant support crew (i.e., frannas for handling counterweights, bog mats etc) & counterweight trucks

Lifting Methodology	Benefits	Limitations
---------------------	----------	-------------

Proposed usage throughout project

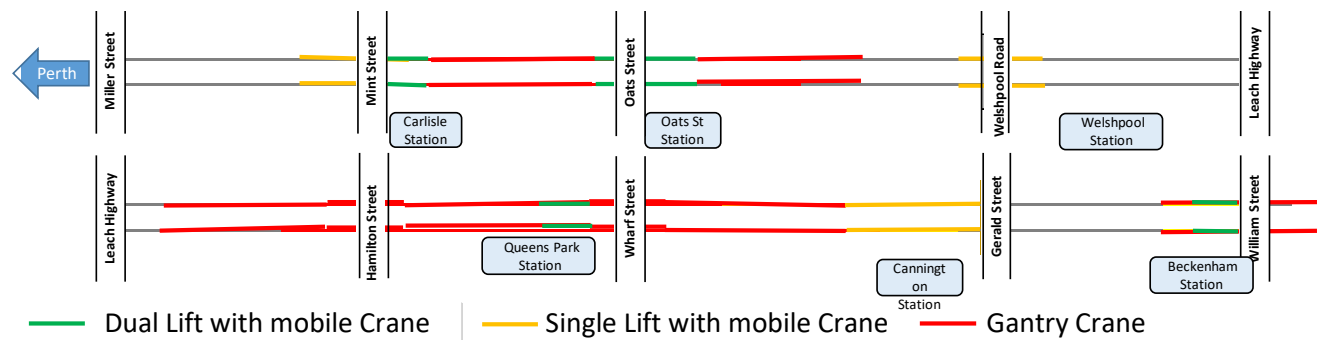

Gantry Crane Crosshead lifts



Dual Crane Crosshead lifts

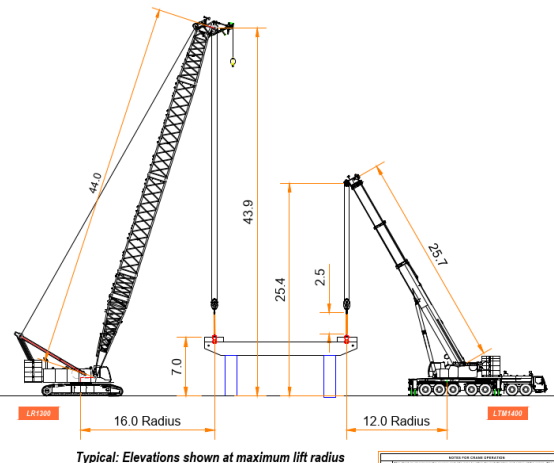

Single Crane Crosshead lifts

Lifting Methodology	Benefits	Limitations
---------------------	----------	-------------

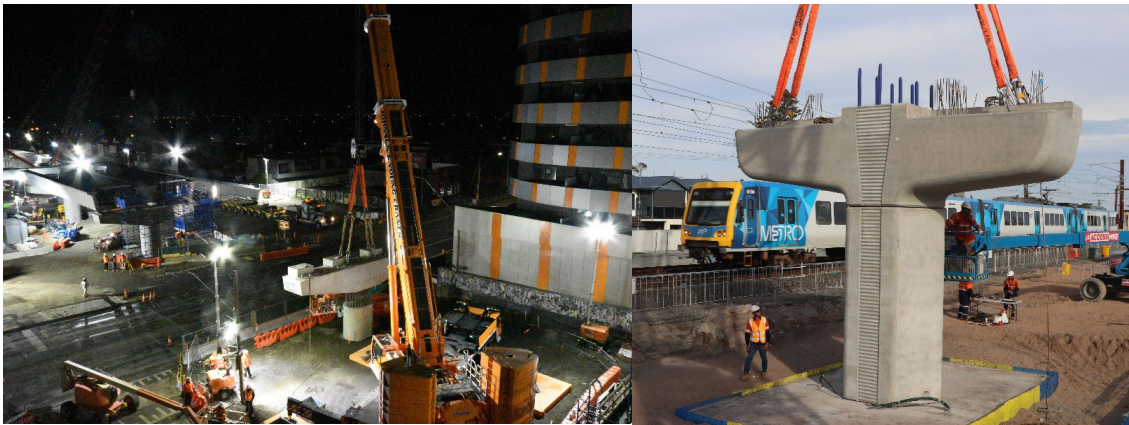

- 16.5.1.1.5 **Crosshead lifting**
- 16.5.1.1.6 **Pier lifting**

Lifting Methodology	Benefits	Limitations
---------------------	----------	-------------

Gantry Crane Lift	<ul style="list-style-type: none"> ✓ Minimised footprint compared to mobile cranes, particularly in package 1 where there is a significant interface with mature trees along the corridor ✓ Increase productivity compared to mobile cranes ✓ Straddles worksite therefore allows for concurrent activities to continue ✓ Dual lifting hooks providing increase precision for landing beams within tolerances ✓ No set up/mobilisation time required for each change in lift location 	<ul style="list-style-type: none"> × Requires limestone running beam, therefore restricting work area × Unable to be used around station precinct due to width of portal crossheads × Unable to be used at road crossings
Mobile crane Dual lift	<ul style="list-style-type: none"> ✓ Provide flexibility around stations ✓ Suitable for lifting at road crossings without impacting road surface 	<ul style="list-style-type: none"> × Crane needs to be “de-kitted” (i.e. removal of counterweights to facilitate movement to new lift location resulting in loss productivity × Crane requires significant support crew (i.e. frannas for handling counterweights, bog mats etc) & counterweight trucks

Proposed usage throughout project

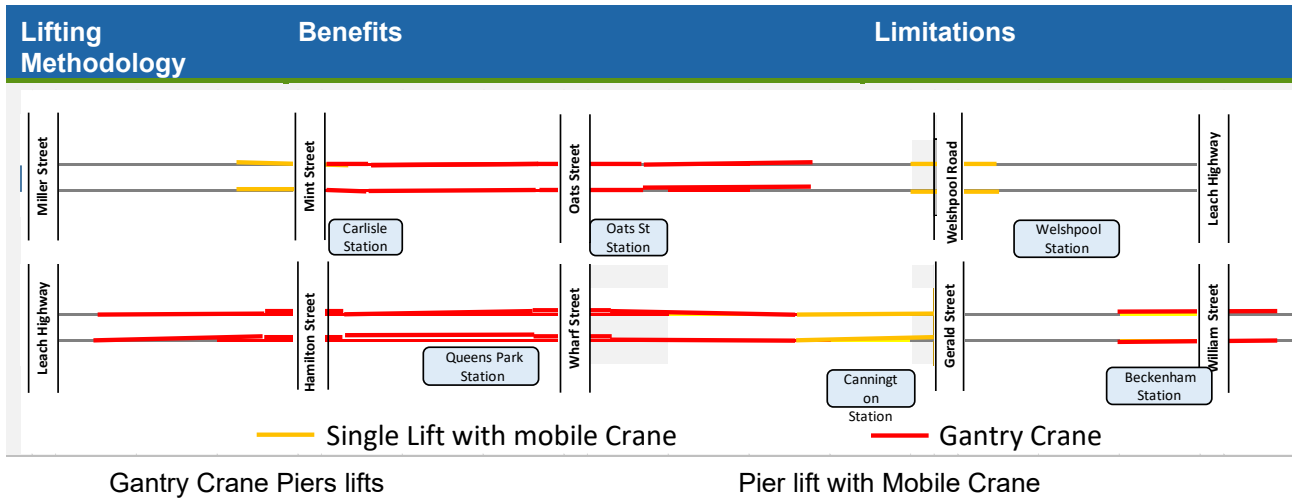

16.5.1.2 Viaduct Substructure

Construction sequence

1. 4x no piles installed
2. Excavation of pile cap extent
3. Pour blinding and 2.5 x 2.5 x 0.5m concrete support pad
4. Break back of piles
5. Reverse form pile cap
6. Pre-tie pile cap reinforcement at ground level (outside of excavation)

7. Lift in pile cap reinforcement cage
8. Pour pile cap & cure
9. Lift in precast pier and land on concrete pad which are levelled by packers
10. Connect a 2-prop system as a temporary support for the piers. Ferrules will be cast into the pier
11. Release precast pier from hook
12. Install grout or self-compacting concrete to tie pier to pilecap
13. Remove props after approved curing duration and land precast crosshead on pier once cured.
14. Lift & erect precast crosshead
15. Pour grout/self-compacting concrete to tie crosshead to pier & cure

16.5.1.2.1 Viaduct foundation

Bored reinforced concrete piles will be used to support the viaduct structures. Key sizes are summarised below.

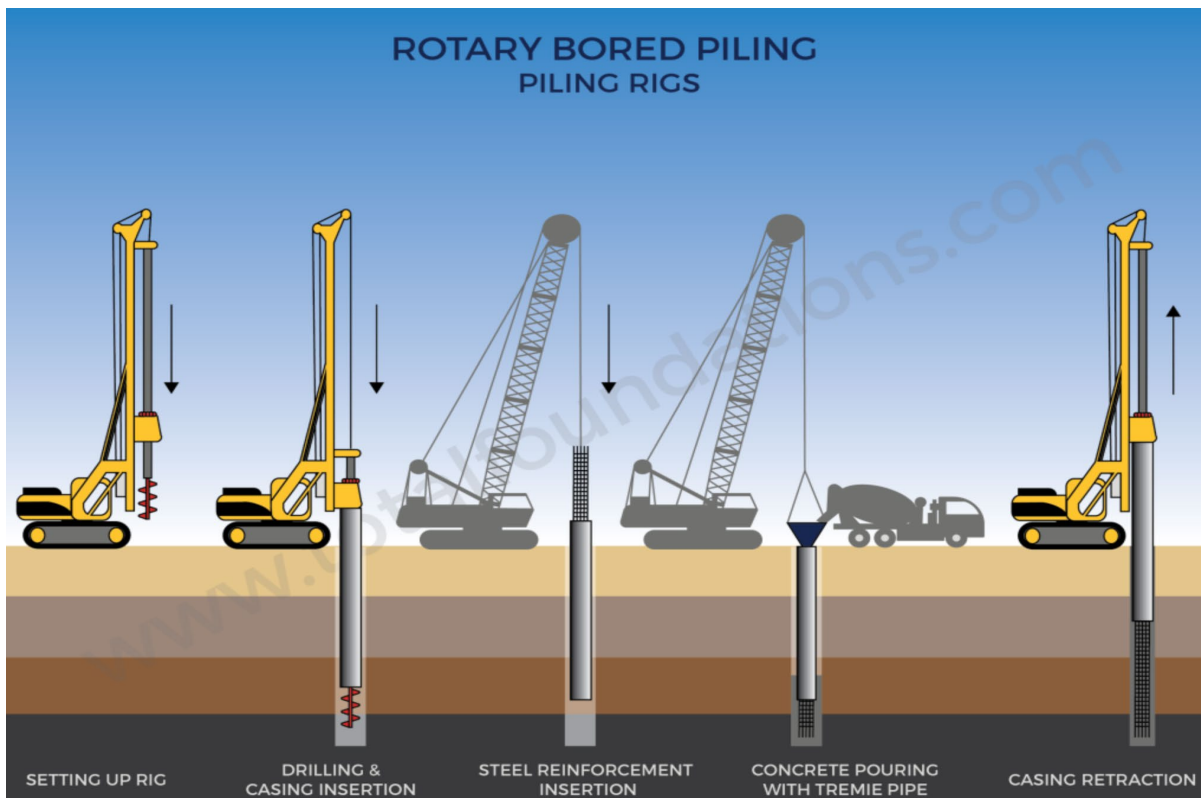

FIGURE 99: ROTARY BORED PILING

16.5.2 Dewatering

- Dewatering is not expected to be required for Viaduct 1 construction
- Dewatering may be required for Viaduct 2 construction; existing ground water level is at RL-3.5
- Dewatering is required for Viaduct 3 construction, existing ground water level is at average RL-2.76, and
- Dewatering is required for Viaduct 4 construction (priced option), existing ground water level is at average RL-2.34.

For all dewatering requirements please refer to the Construction Environmental Management Plan (CEMP) for further details.

16.5.3 Excavation

- Prior to commencement of excavation works, a Ground Penetration Permit (GPP) will be created, reviewed, and signed by engineers, supervisors and work crews.
- NDD will take place where required to confirm services are positively identified. Workers involved in excavation works are required to be familiar with ALUAs Operation Mandatory Requirements (OMR’s) for Excavation and Trenching.
- Barriers, covers, exclusion zones, edge protection, lighting and/or signage must be provided to prevent people, plant, objects, and equipment falling into excavations and trenches. The controls will align to OMRs
- Survey marks the depth to bottom of pile cap with an offset to the center of pile cap in two directions.
- Using a 25t excavator (or similar) pile cap shall be excavated to size, and
- Hardstand levels are an average of 350mm above the top of pile cap, with the depths of excavation being between 1.55-2.05m.

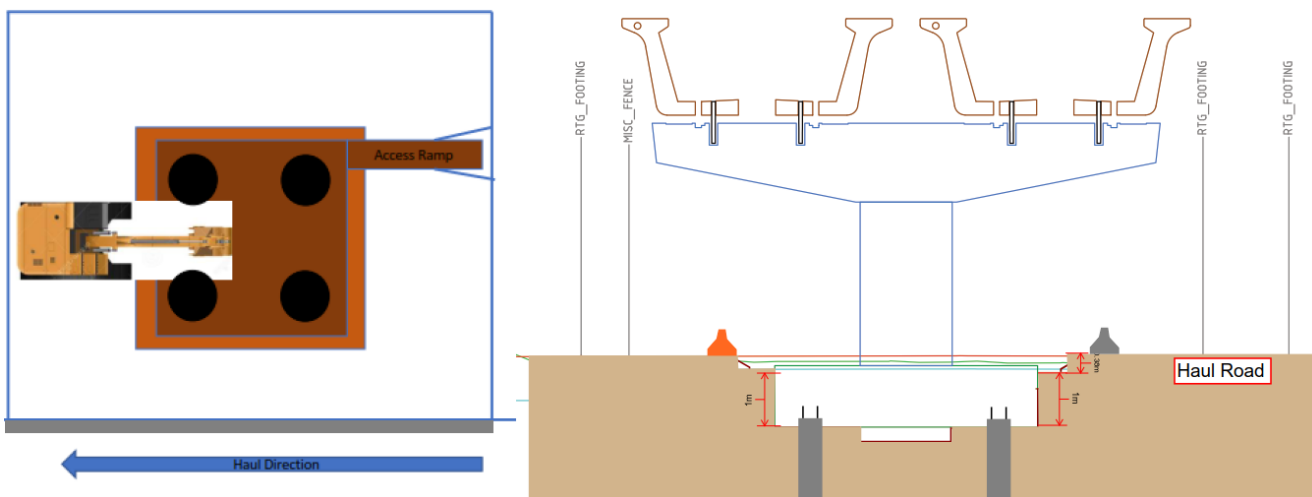

FIGURE 100: EXCAVATION EXTENT

16.5.4 Safe Excavation

- To ensure safe excavations construction of bench or batter will take place as the excavation deepens.
- Benching will be 1H:1V with no vertical wall greater than 1m
- Delineation fencing/barrier will be used to delineate the haul road from the excavation and edge protection of flagging or similar around the perimeter of the excavation are always to be in place
- Construction methodology has been set to minimize need for workers to enter excavation, however a dedicated entry point is to be constructed for workers to enter the area at a maximum batter or 1:2. concrete will be placed on this as soon as practical
- To limit edge loading and chance of collapse:
 - Maintain the excavators front of tracks 1m clear from excavation edge
 - Maintain Stockpiled material 2m clear from excavation edge

- Excavations are to be inspected daily prior to workers entering or after weather events

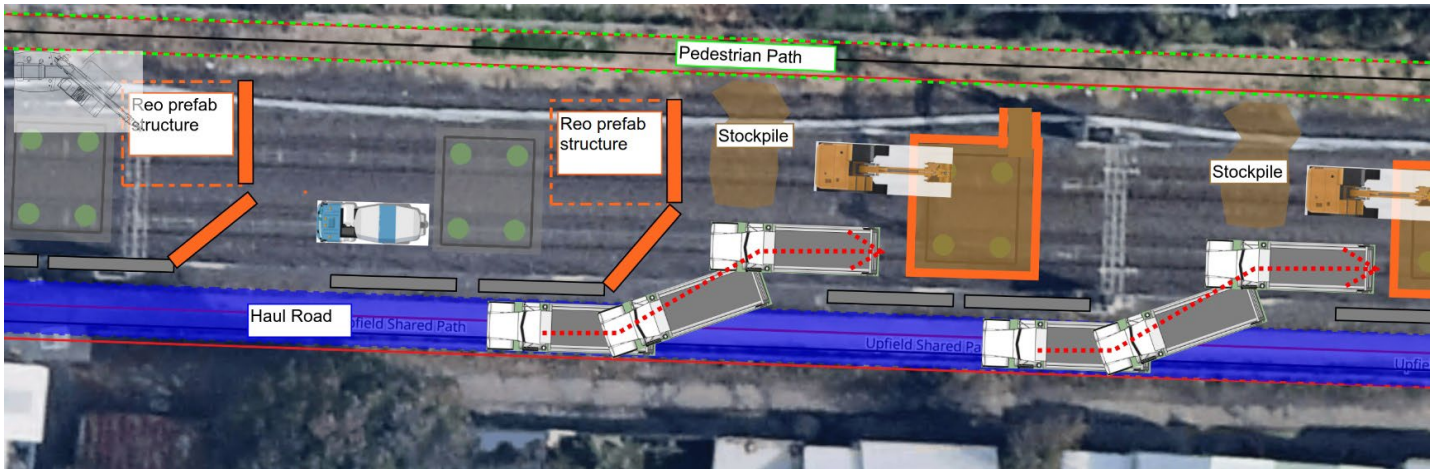

FIGURE 101: TYPICAL SITE LAYOUT

16.5.5 Detailed Excavation

- A smaller excavator will be used for detailed excavation of the piles and access ramp, and
- A spotter, in a safe location, with radio contact shall be used to guide and advise bucket location.

16.5.6 Blinding and pile break back

- A mass concrete Pad will also be excavated (2.5m * 2.5m * 0.45m), and poured with the blinding layer, which will support the load of the pilecap once landed, and
- Blinding is to be 15MPa mix to allow for the install of precast pier.

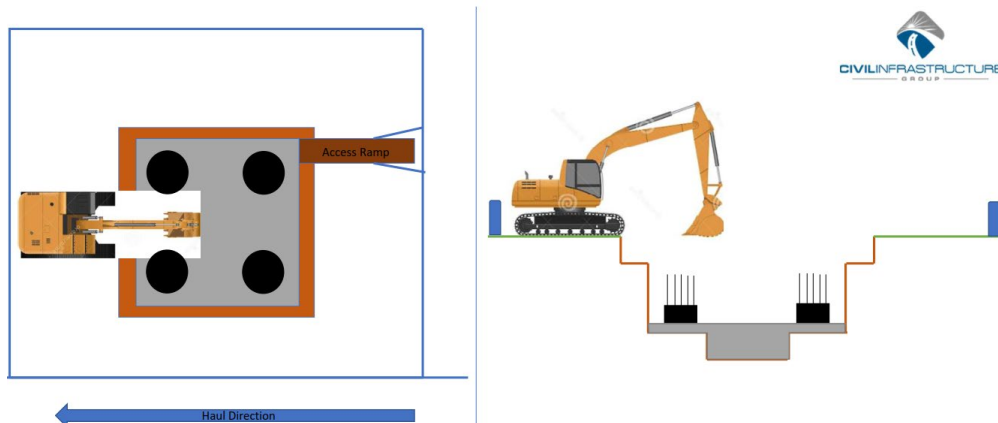

FIGURE 102: BLINDING AND SUPPORT SLAB

16.5.7 Pile Cap Reverse Form and Reinforcement installation

- To minimise excavation footprint in the narrow corridor "reverse form" methodology will be used for the pile caps

- 150mm thick concrete walls along the pile cap extends to act as sacrificial form work. This will be sequenced to be poured after blinding and before the reinforcement is installed
- A blockout for drainage and other conduits will be maintained so they can be connected. There is a 300mm widening at the top 200mm to allow for handrail and anchoring. The blockout will be secured using tire wire and connected to the reinforcing, and
- Temporary works design is to be completed by a certified temporary works designer, which will support this construction approach.

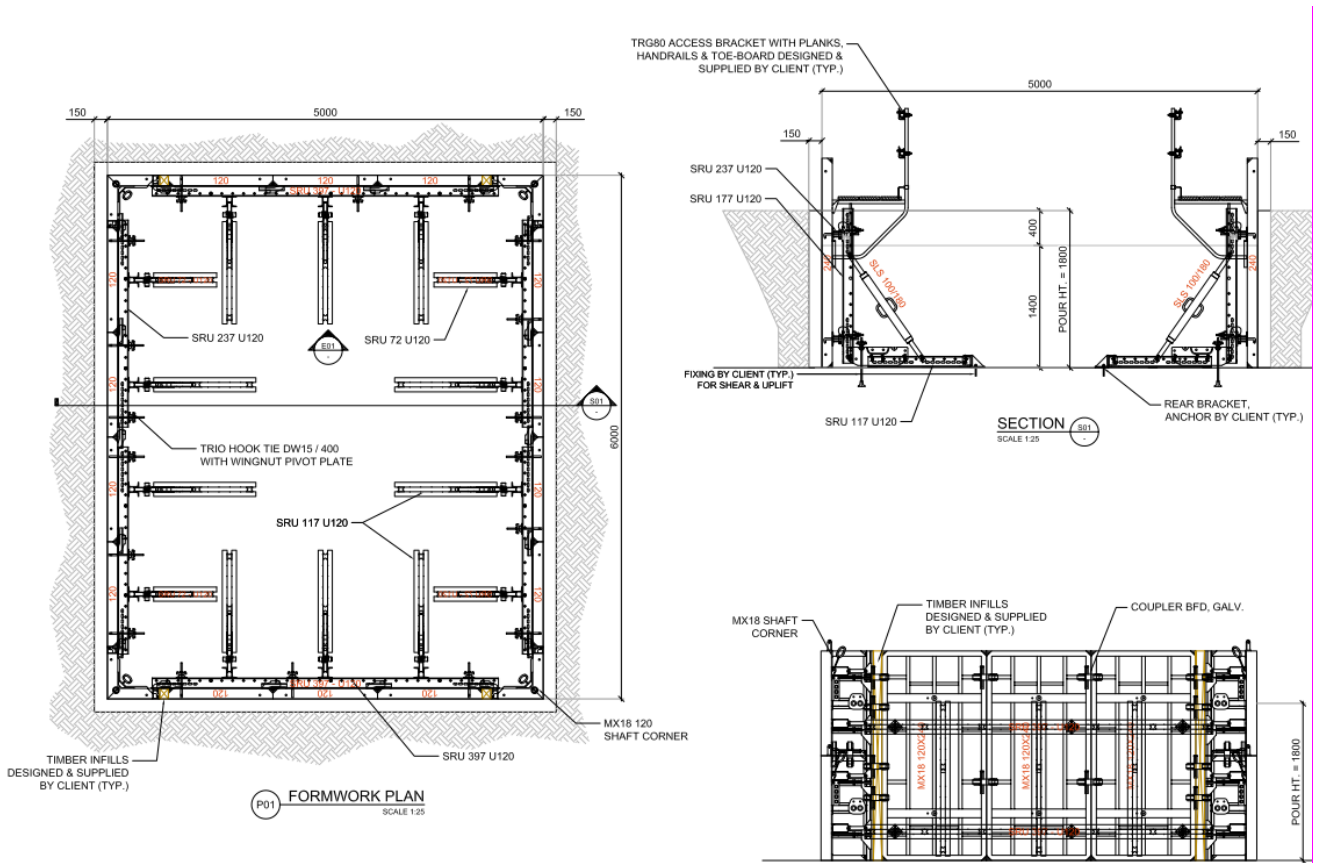

FIGURE 103: REVERSE FORM DESIGN

16.5.8 Sequence

- Reverse form will be delivered to site in 4 pieces
- Each piece will be lifted and lowered into excavation via certified lifting points with a 20/25t franna or slew crane
- Crane is to maintain minimum offsets to the excavation
- Once lowered in place it will be fixed to the blinding via concrete anchors
- Once reverse form system is dropped into excavation it now acts as fall protection as it has preassembled handrails, and
- Before the last side has been dropped in a crane able access system will be installed for access into the hole.

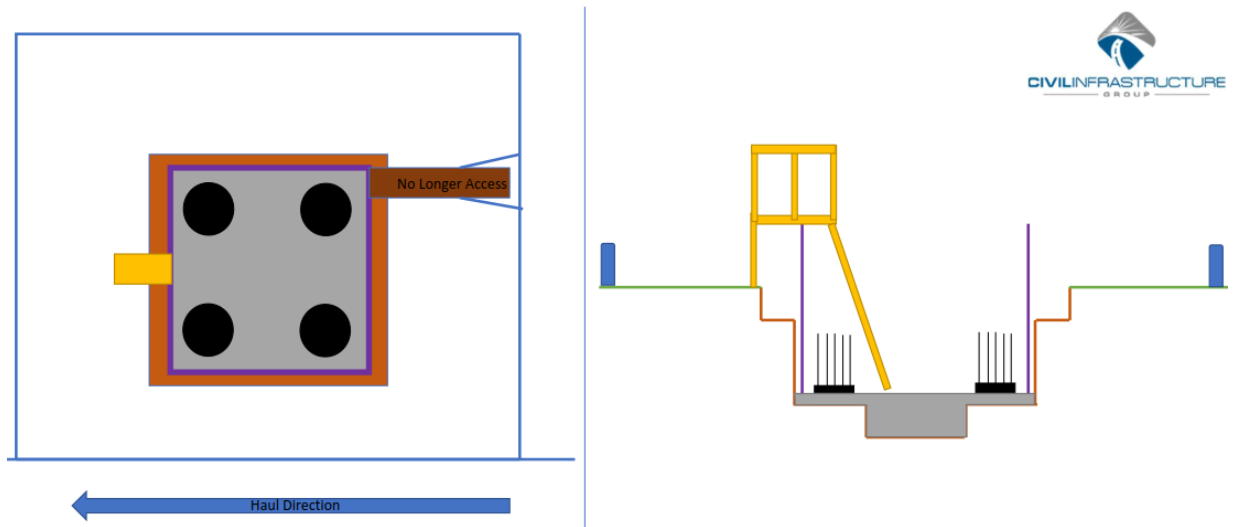

FIGURE 104: REVERSE FORM INSTALLATION

- Access ramp will be backfilled with insitu material
- Reverse form will be poured with 40MPa agila or concrete mix
- Temporary handrail will be installed into handrail sleeves in reverse form concrete
- Reverse form will be stripped and lifted out the following shift once the form has reached the required strength. Strength to be verified prior to removing forms
- The system is designed to be released from the concrete surface via corner pins
- Access will be via crane able chariot ladder and gate/gap in handrail

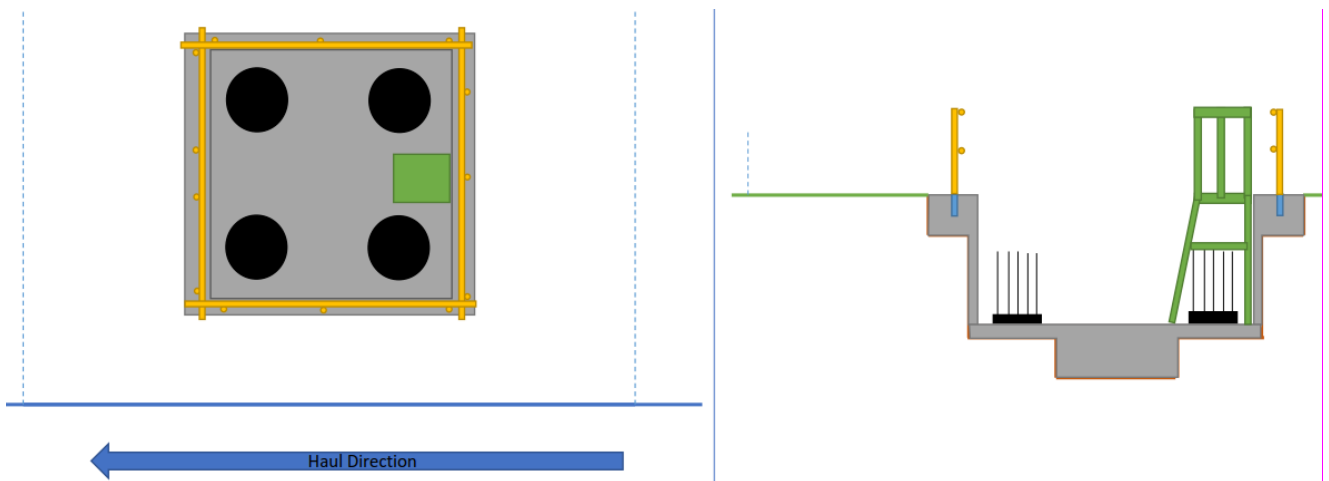

FIGURE 105: REVERSE FORM HANDRAILS

16.5.9 Reinforcement Installation

- Whilst the reverse form concrete is curing, the pile cap reinforcement is to be constructed on the hardstand, adjacent to the pile cap and lifted from certified lifting points in once blinding and reverse form has cured and the formwork stripped.
- Once blinding is poured, the pile starter bar locations will be taken and transferred to a ply template

- Piling crew is to use a straight bar guide when installing pile starters to ensure the pile cap reo will fit
- Template will be sat on ground with replica starters and location of CHS posts and pile cap reinforcement cage built at hardstand level a few meters away from the excavation. The template will ensure when cage is dropped in it will not clash with pile starters
- All bars except the middle-spliced section of top mats T1 & T2 are to be tied before lifting in the cage, and
- Once pile-cap cage is complete it will be welded throughout to ensure the reinforcement can be safely lifted as one unit. An approved Temporary Works Design will be in place to support this methodology. The design will also specify the designated lifting points.

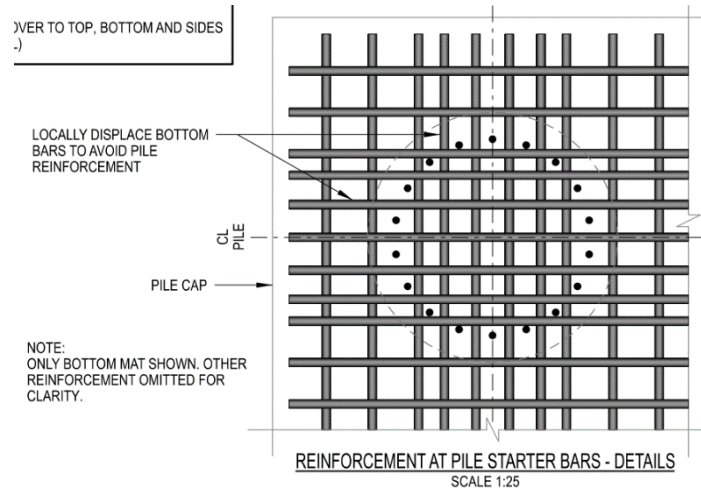

FIGURE 106: LOCALLY DISPLACED BARS TO AVOID PILE CAP REO

- Inside excavation, packers are surveyed and set for precast pier install. These packers must be fixed to the support slab to ensure it doesn't move during the precast pier installation.
- Install conduit sleeves over pile starter bars to act as guides for pile cage
- Lift cage into position via 25t franna or slew crane. To be lifted via certified lift locations only. Weight of cage is approximately 11t. The cage will be lifted through the plastic conduit starter bar guides.
- Final positioning of cage via concrete aspro placement and check to ensure within correct tolerances
- Remove conduit sleeves

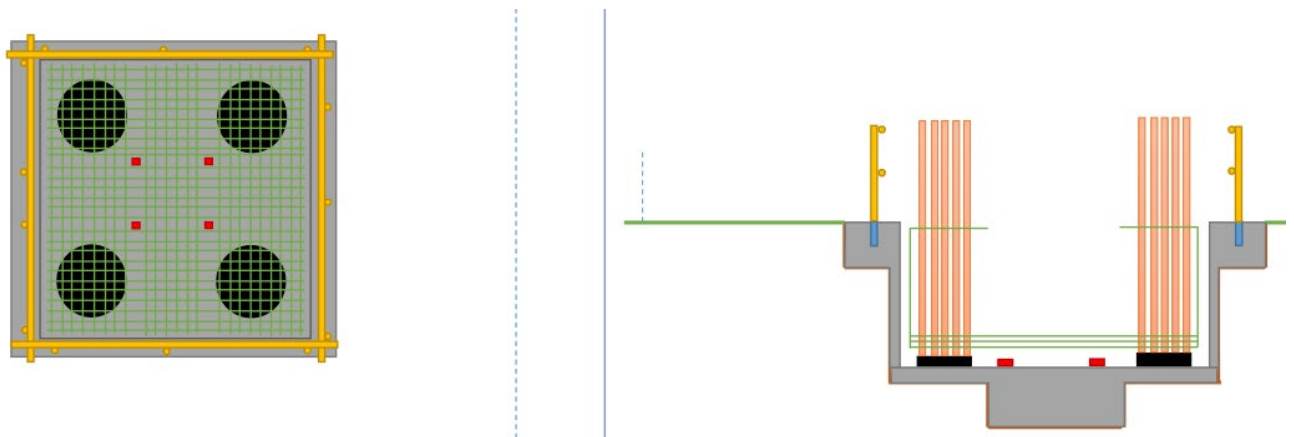
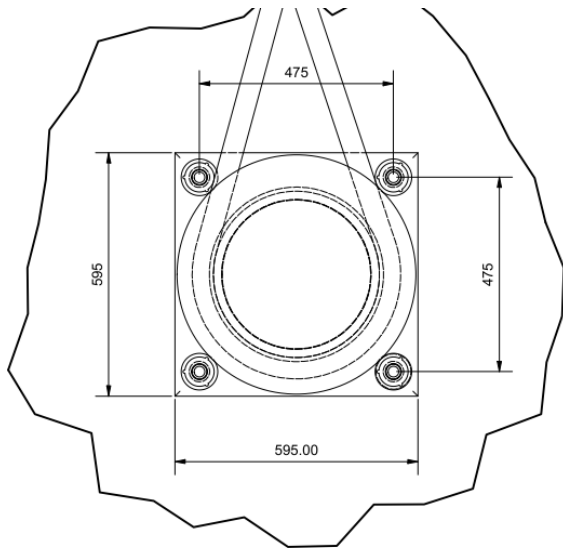

FIGURE 107: REINFORCEMENT CAGE INSTALLATION

16.5.10 Lift Design

- Due to the weight, curved profile and requirement to rotate the piers, a custom lift design is required
- A trunnion design was chosen as in consultation with ALUAs heavy lift team as the most efficient design due to a number of factors
 - No complex cast in items reducing cost
 - Minimizes load on tailing crane (8t), significantly reducing tailing crane size and easing congestion
 - Simplified onsite lifting process
- 4x 40mm cast in conduits are cast into the precast pier as shown in the above shop drawing
- M36 threaded rod is thread through the conduit voids
- 2x steel plate trunnion lift points are bolted to the pier via the M36 rod
- These bolts are TB bolts and to be properly inspected via precast pier installation checklist
- 6 sets of trunnions are to be fabricated.



DETAIL B

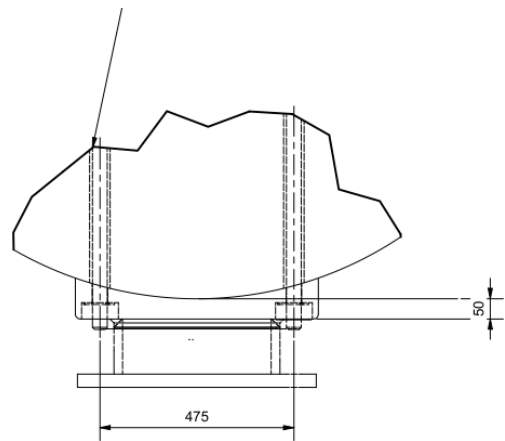

DETAIL A

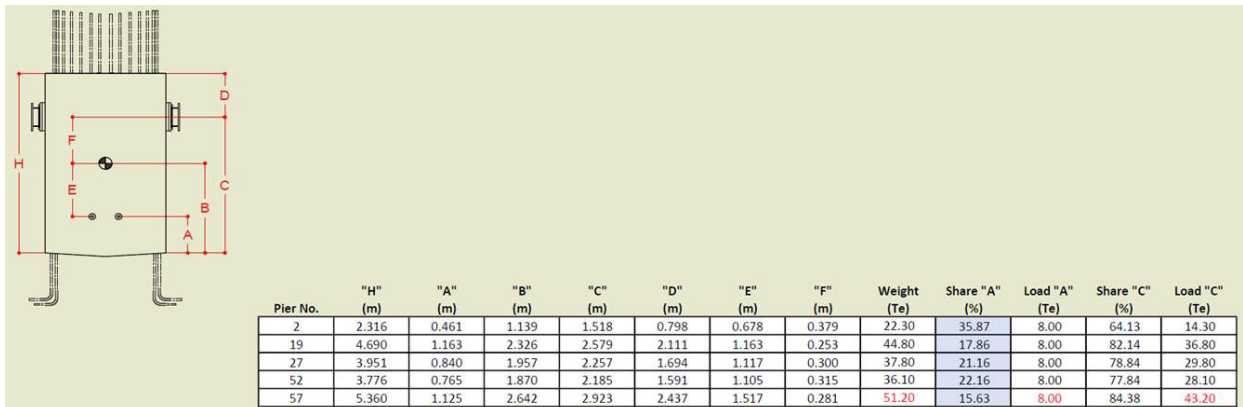

FIGURE 108: TRUNNION DETAILS AND LOAD SHARE ON EACH LIFT POINT

16.5.11 Rigging

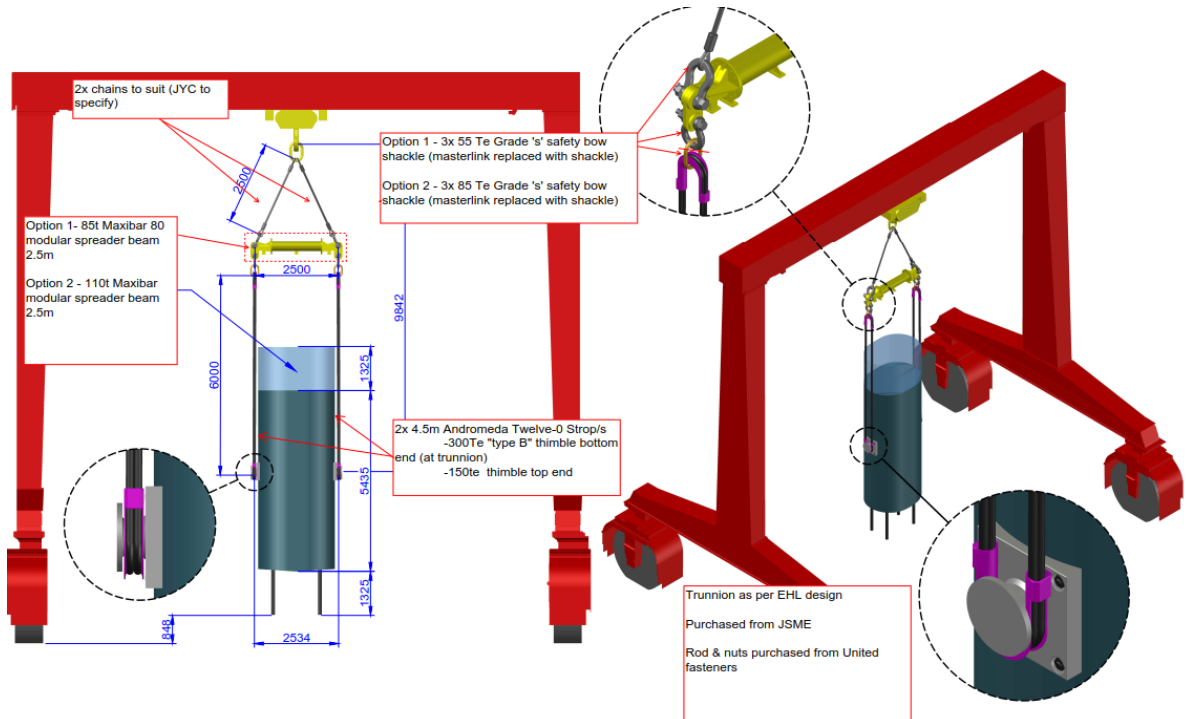

FIGURE 109: RIGGING DIAGRAM

16.5.11.1 Plan position and rotation control

- To aid with control of landing the pier in correct plan position and within acceptable rotation tolerance we have implemented the following controls
 - 8x survey points on the pier which will be shot to 3mm accuracy usual a total station
 - Development of a simple guide which will help the crane land the pier in the correct position. Several methods are going to be used in the install trial and the best method implemented.

16.5.11.2 Installation Procedure

- Main and tailing Crane Positioned, and rigging set up as per critical lift plan
- Precast Pier delivered to site flat on transport, sitting in a cradle on the flat 500mm face
- Precast pier lashing to be removed
- Precast Pier inspected to be inspected using an approved ALUAs checklist. The following items will be checked.
 - Lift points (trunnions and foot anchors) checked for defects
 - Inspected for cracking
 - Birth Certificate received and checked
- Both the main and tailing crane lift the pier off the transport truck. The tailing crane will assist the main crane to rotate the pier upright. Once upright, the tailing crane is derigged
- Transport to drive forward to clear area. (if not possible and the lift is in proximity to the truck cabin the driver is to leave the vehicle until the lift has cleared the area)
- Rigger on tag line to slowly track/slew pier into position

- When tracking with Rubber Tyred Gantry crane, the pier is to be kept <1m off ground and tracked along haul rd.
- Pier is to be lifted into final position sitting on packers in the pile cap. Once pier is landed, survey will shoot the pre-installed targets to ensure pier within height and plan position tolerances and vertically plumb
- 2x Props are then to be connected to the pier and corners of the reverse form via M20 anchors. There can be lifted via hand or franna if over 20kgs. Access to the precast pier connection will be via EWP
- Props can be used for micro adjustments on pier while crane is still holding a portion of the weight
- Once in final location and props are securely connected, pier is detached from rigging. Crane cannot release pier from hook until both props are connected to the pier
- Lift points are to be unbolted from pier using an EWP (this can be completed at later stage if crew needs to move onto L-beam or crosshead install)

16.5.12 Crosshead installation

- After curing, lift and install crosshead with gantry crane/mobile crane.
- Install precast crosshead on shims
- Once the precast crosshead is installed vertically within tolerance +/-10mm, grout joint and duct from EWP at top. 2 x EWPs with spotters will assist with lifting operation.
- Remove temporary support after curing.
- Bridge Bearing arrangements using elastomeric bearing have been selected in preference to mechanical bearings for ease of maintenance and replacement. Bearing are located on plinths to keep them away from run-off and potential debris build up.
- FRP team to install elastomeric bearings with EWP. 2 x EWPs with spotters will assist with lifting operation.
- Elastomeric bearings shall be installed on shims and surveyed into final position.
- FRP crew will then install grout forms, prep surface and fill the voids with grout to lock elastomeric bearings into position.
- Strip the ground form and cut the edge to 45 degree chamfer and apply suitable curing compound.

16.5.12.1 Pedestal Grouting

- Surveyor and labourer in EWP to mark out the four corners on crosshead and heights on formwork for each pedestal
- Formwork will be fixed into crosshead and a 10mm chamfer fixed on the top face
- Concrete surface to be cleaned and moistened before pouring pedestals
- Grout product will be Tecgrout HS / HES or approved equivalent complying with VR610.28
- Grout is to be mixed and placed in line with the manufacturer specifications
- Extra care is to be taken to ensure pedestals are constructed within 3mm tolerance
- Once grout pour is complete, pedestals are to be covered during curing to ensure no adverse effects from weather
- A final inspection (checking for level, finish, and bond to crosshead) and survey of pedestals is to be completed before beam landing
- Cracked pedestals are to be jackhammered out and repoured

- If pedestal is out of tolerance, it is to be grinded back or lifted with an approved epoxy product as approved by design

16.5.13 Viaduct Superstructure

16.5.13.1 Precast L-Beams Transport and Stockpile Area

- Precast manufacture shall allow for quality inspection by PTA and ALUA to check the concrete finish of L-Beam
- Strategy is to deliver all precast L-Beams via Roe Highway, William Street, Sevenoaks Street and Bank Street. Modifications to traffic islands will be required at the corner of William Street and Sevenoaks Street to facilitate turning circle. Furthermore, the Sevenoaks / Welshpool rd will be modified to facilitate the movement of L beams and construction delivery vehicles between Sevenoaks and Banks St.
- Team has carried out transport route study and identified only 1 low-lying OH power line need to be relocated along Bank St in Zone 2.
- An average 24hr cycle will involve delivery of ,1 Crosshead, 1 Pier , 4 L-Beams, several RE panels delivered to site.
- Lashing and transport detail will be provided by transport company. All transport and lashing requirements will be designed by a certified temporary works designer.

16.5.13.2 Precast L-Beams installation sequence

- Installation of viaduct L beams will be installed as per below sequence.

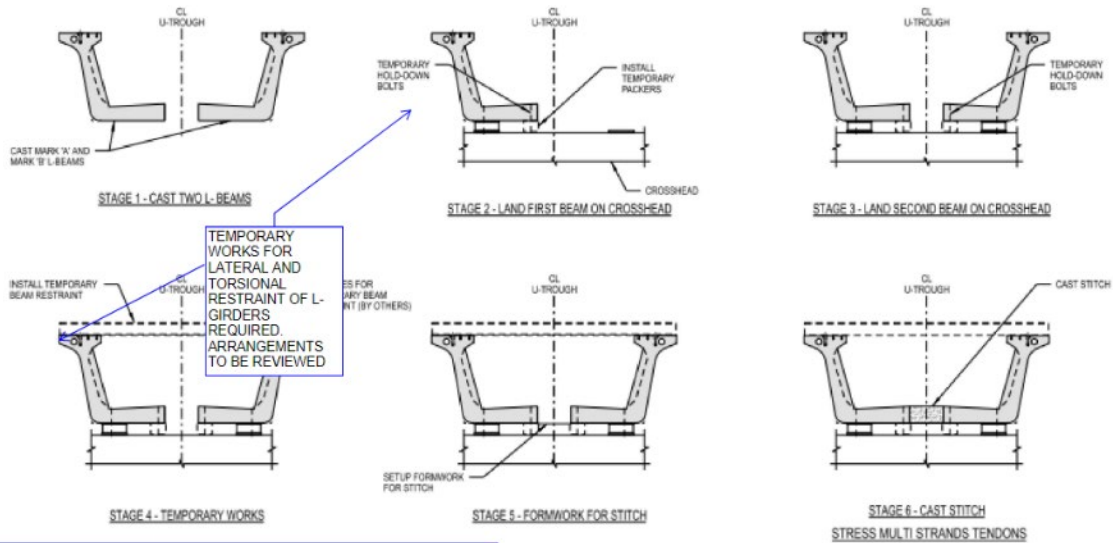

FIGURE 110: L-BEAM INSTALL SEQUENCE

- Construction sequence shown based off single girder lifts and stitch pour completed in-situ.
- Post-tensioning to be applied after stitch reaches 40MPa. Post-tensioning will take place after completion on 1 or 2 spans. Post-tensioning ducts will be located in the precast L-beams as shown below.

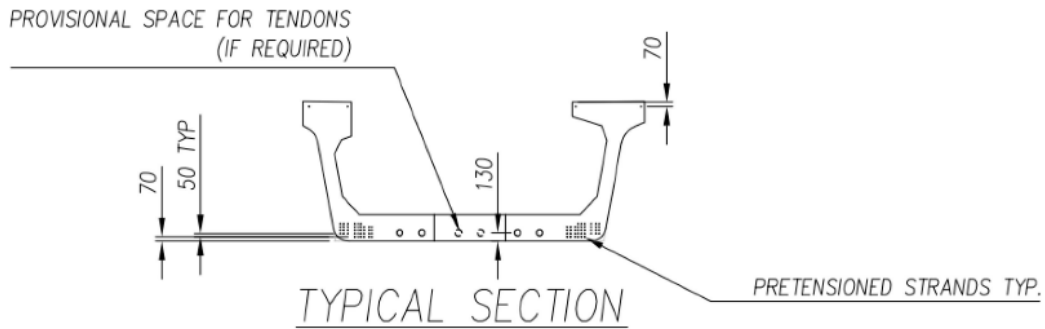

FIGURE 111: TYPICAL SECTION

- Ancillary items (handrails, screens) may be attached to girders prior to lifting
- Erection sequence of girders on twin-track crossheads to complete up and down main on a single span prior to erecting the following span

16.5.13.3 Precast L-Beams stitch pour

Complete construction of viaduct trough will require a 2 stage pour. Stage 1 will be complete the longitudinal pour between the L beams and the State 2 will be completed after the viaduct has been post-tensioned. Distinct concrete stage pour is shown on below diagram.

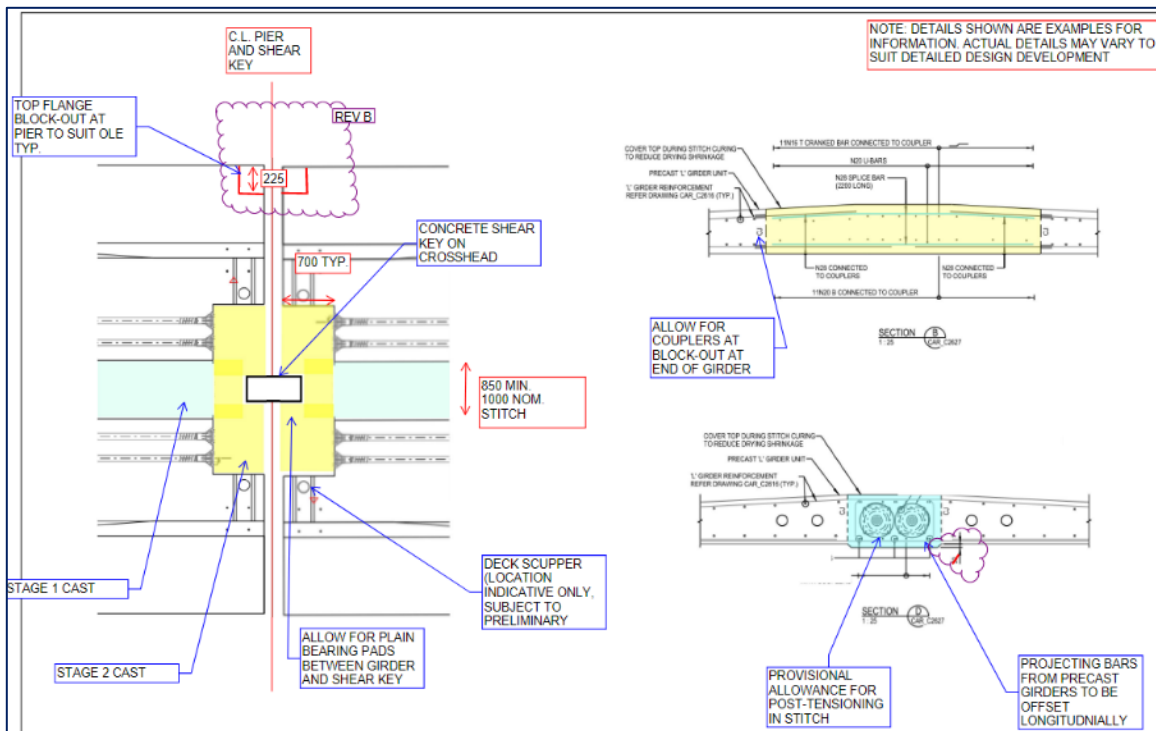

FIGURE 112: STITCH POUR SEQUENCE

Each stage is described in greater detail below.

Stage 1 cast

- Stitch pour section will be formed up using a permanent steel plate designed to support wet concrete.
- FRP crew will install reinforcement within cast 1 cross section. It is not anticipated that post tensioning ducts will be required within this section.
- A boom pump will be used to deliver concrete within the cast 1 cross section.
- Cast 1 section will be chemically cured.
- Upon curing completion and reaching the minimum concrete compressive strength the tie bars will be removed and patched up with suitable non – shrink grout.

Stage 2 cast

- Upon completion of post-tensioning activities preparation for stage 2 cast can commence.
- First activity will be to insert the starter bars within the ferrules followed by installation of formwork over the pier.
- Reinforcement crew will install the reinforcement.
- Formwork crew will install the shear key blockout as shown above and another remaining formwork.
- FRP crew to pour the cast 2 section using a boom pump.
- Cast 2 section to be chemically cured.
- Upon curing completion and reaching the minimum concrete compressive strength, formwork will be removed, and tie holes will be patched up.

16.5.13.4 Metalworks and Screen Installation

Completion of the Viaduct trough will require installation of following metalwork elements. Walkway handrails and outer screens. A typical cross section is shown below.

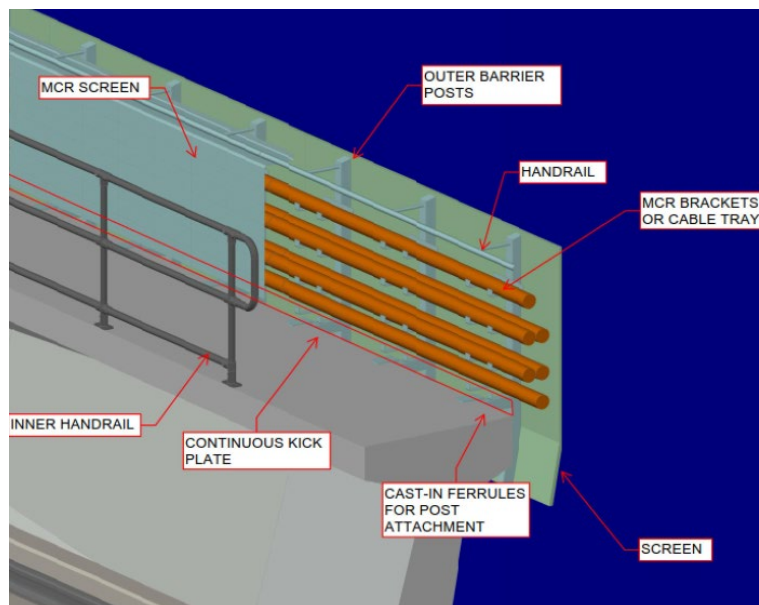

FIGURE 113: TYPICAL CROSS SECTION

16.5.13.5 Walkway handrails

- Walkway handrails will be fabricated offsite in a CC3 qualified steel fabricator. Walkway handrails will be fabricated in a manner that allows for site assembly without field welding. This will accelerate speed of construction.

- Walkway handrails will receive hot dip galvanising surface treatment. Thickness of the HDP will be advised later by our durability consultant.
- Walkway handrail will be fixed to SS316 cast in ferrules. Walkway fixing will be Stainless steel and they will be isolated from the galvanised walkways via the use of isolation washers and grommets. A 16t city crane will be used to land walkway handrail bundles within the viaduct trough and installation will be undertaken via 4 men rigging team with railing fall arrest system, supported with an EWP.
- SS316 cast in ferrules will be supported during the L beam precast process to ensure that necessary fabrication tolerances are achieved.

16.5.13.6 Outer barrier posts and Aluminium screens

- Outer barrier posts will be fabricated offsite in a CC3 qualified steel fabricator. Outer barrier posts will be fabricated in a manner that allows for site assembly without field welding. This will accelerate speed of construction.
- Outer barrier posts will receive hot dip galvanising surface treatment. Thickness of the HDP will be advised later by our durability consultant.
- Outer barrier posts will be fixed to SS316 cast in ferrules. Walkway fixing will be Stainless steel and they will be isolated from the galvanised walkways via the use of isolation washers and grommets.
- 3mm anodised grade aluminium screens will be fixed to the outer barrier posts. To dissimilar metal corrosion, panels and posts will be isolated with rubbers strips and appropriate fasteners.
- Installation will be undertaken via 4 men rigging team with railing fall arrest system, supported with an EWP and 16t city crane.
- SS316 cast in ferrules will be supported during the L beam precast process to ensure that necessary fabrication tolerances are achieved.

16.5.14 Embankment, Retaining Walls & Abutments

16.5.14.1 Retaining wall & abutment -Foundation

Viaduct approaches consists of two distinct areas. Primary area of the main rail embankment founded on Rigid inclusions (CMC). Secondary area of the approach is the section occupied by the in-situ abutment structure. As this section will be exposed to more significant longitudinal forces it will be in turn founded on bored reinforced concrete piles. Each specific ground formation is described in greater detail below.

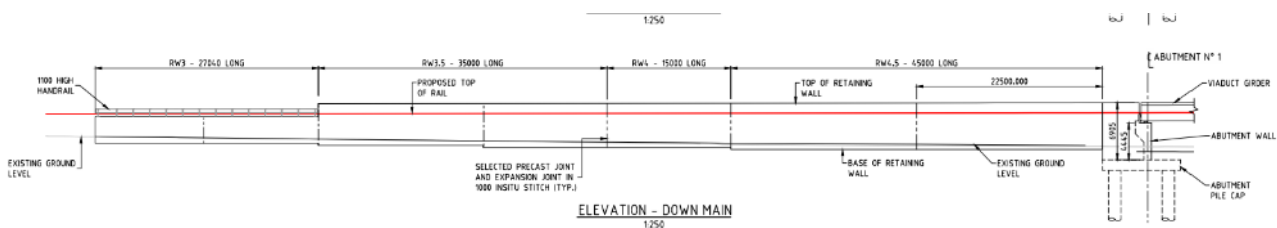

FIGURE 114: GROUND FORMATION DETAIL

16.5.14.1.1 CMC/Piling pad hardstand preparation

In order to optimise value for money the general access track will be combined with crane piling pad.

- 300mm limestone will be placed along the length of the embankment located north of Leach Hwy. For section south of Leach Hwy this thickness will be increased to 600mm.
- Install limestone hardstand and access track as illustrated in below cross section.
- FEL and twin drum rollers will be used to spread the limestone.

- Hardstand to be verified via MDD compaction prior to use verification. Limestone hardstand will be placed to 95% compaction and will be verified via nuke tests.
- The hardstand will extend 1m past of the track side and 3m past on the roadside to provide adequate space for material and equipment delivery/movements

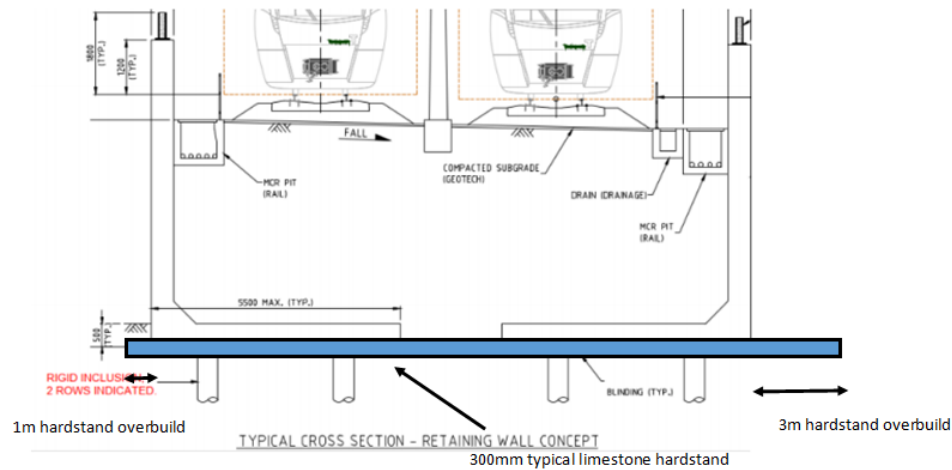

FIGURE 115: HARDSTAND PREPARATION

16.5.14.1.2 CMC Installation methodology (where required)

Embankment retaining foundation preparation are founded on rigid inclusions in the form of Controlled Modules Columns (CMC's) under the footprint of the rail embankment as shown in below image.

CMC's will be installed within the embankment footprint except for where the embankment backfill is less than 3m. CMC pile sequence will be generally as illustrated in below image. Concrete will be supplied from a ready-mix concrete batch. CMC's will furthermore receive a reo cage.

Key drawing cross sections and extent of CMC's is shown below along with summary of application rate of CMCs for different sections of embankments.

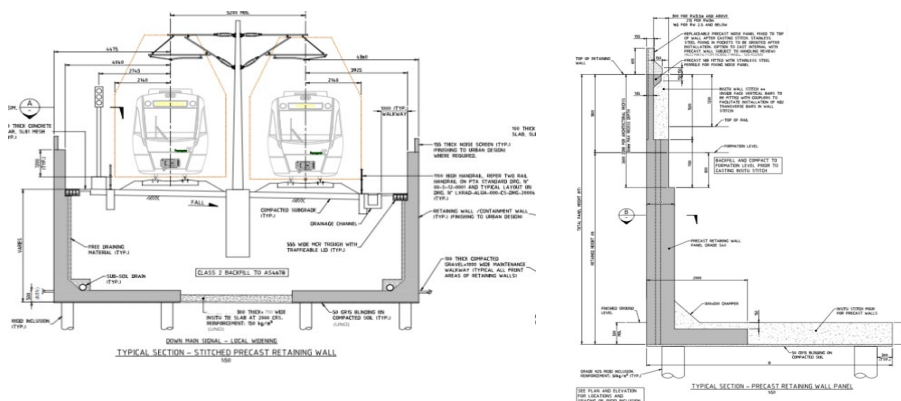

FIGURE 116: CMC CROSS SECTION

Listed below are key construction steps for delivery of CMC rigid inclusion piles-

- CMC rig will be a Liebherr LB28s provided by Geotechnical Engineering. Typical setup as shown in below image.

- A 300mm thick prepared limestone hardstand will be provided for the rig as per temporary works design advice.
- Works will be executed by a pilling contractor that will provide the concrete and all permanent materials
- Outside row of CMC (closest to vertical face) to be reinforced, and
- Internal row of CMC rigid will be non-reinforced, however allow for a 2m long N16 bar with 300mm return cog to be inserted to act as a tieback to the stich slab pour. This will act as a temporary tieback during backfill. CMC for the entire length of the embankment will be completed offline without interference to live rail operations.

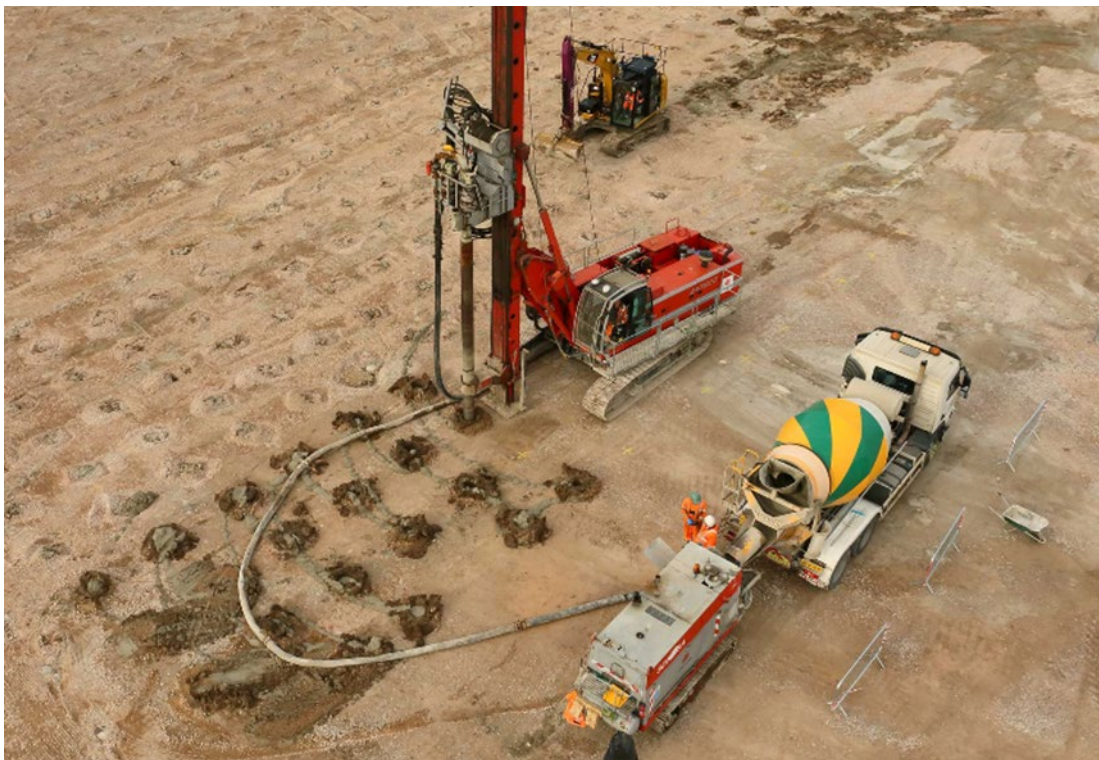

FIGURE 117: TYPICAL CMC EQUIPMENT SETUP

16.5.14.1.3 CMC installation near live rail operations

CMC can be installed on dayshift for sections behind the GE fence. Rig is deemed stable when placed over Engineered hardstand material and CMC is a lateral displacement method. Survey monitoring of the rail track will be required during the period of CMC installation. ALUA will allow for survey monitoring during the CMC construction of the East retaining walls due to risk of lateral displacement caused by CMC's.

16.5.14.1.4 Pile Foundations

Pile foundations for the abutments shall be bored concrete piles and will be installed in accordance with the process shown below.

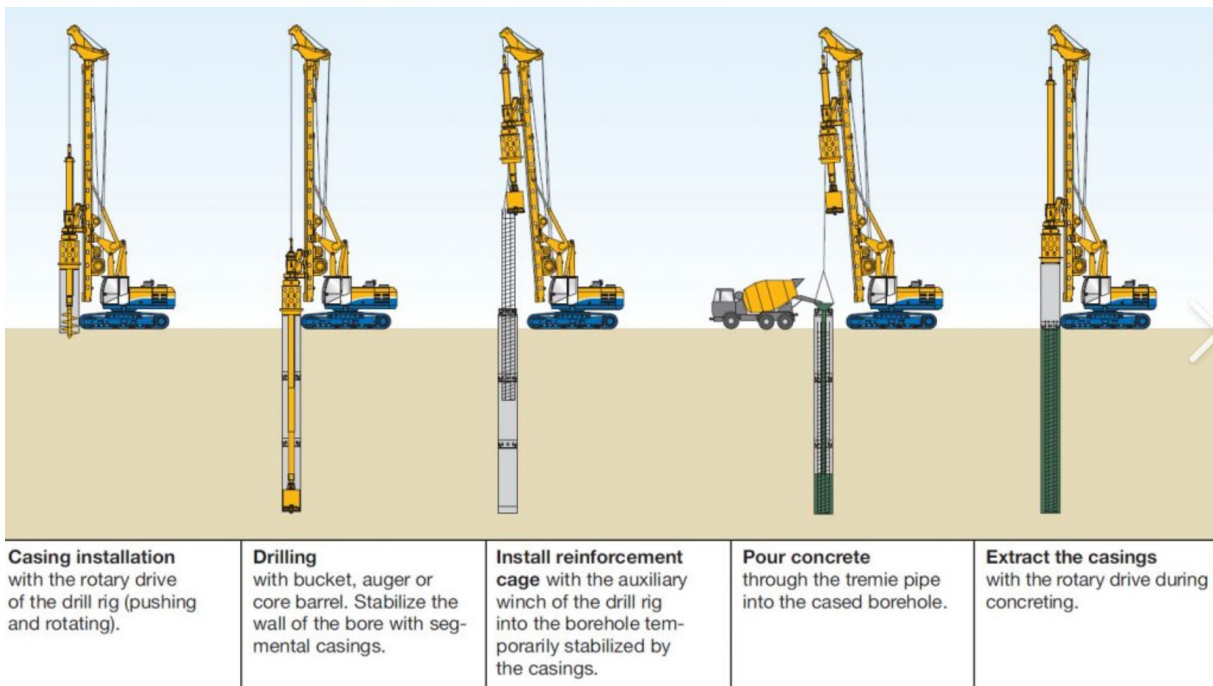

FIGURE 118: BORED PILE INSTALLATION - TYPICAL PROCESS

- Bored pile rig will be a Liebherr LB28s provided by the piling contractor.
- A limestone hardstand will be provided for the rig. Hardstand located North of Leach Hwy will be 300mm thickness and South of Leach Hwy will be 600mm thickness.
- Position and drill the first section of the drill casing (recoverable steel casing as temporary support during the boring process)
- While drilling, the drill casing – inside equipped with a drilling head fixed on a rod - is oscillated into the soil. (Back and forth movement / twisting in place)
- As the drilling process progresses, soil is removed from the borehole by the excavating tool (bucket barrel excavating the pile shaft) and additional sections of casing are jointed (added) to protect the soil from collapsing into the borehole during drilling. When drilling in non-cohesive soils below the groundwater level, a bentonite overpressure (Δh) should be created in the temporary casing.
- After reaching the design depth, clean-up of the borehole front, remove drilling tool, desanding (bentonite) pumped out from the bore.
- Once the desanding process has been completed, insertion and lowering of the reinforcement cage in short segments can commence. Cages will be prefabricated in max 12m length and will be mechanically spliced on site as shown below. Cages will be factory manufactured complete with pre-welded ligs and certified lifting points. This eliminates the possibility of cages falling apart during lifting. Once reinforcement cages have been installed, concrete tremie pipe will be installed in 3 m lengths.
- In the presence of bentonite, concreting is carried out by means of a tremie tube to avoid segregation of the concrete (tremie pipe technique).
- During the continuous concreting process, the temporary casing elements are progressively withdrawn whereby the concrete forms the pile shaft.
- Dynamic and static testing will be required for this individual pile group

16.5.14.1.5 Breaking back piles

Following piling excavation, the piles will be broken down and prepared for in-situ pile testing. Proposed pile

head cutting method is to utilise Qui cutter. The straight bar reinforcement projection is required to be foam wrapped. The product expands during concrete curing and creates a crack around 50mm above final cut-off level and the pile head is then removed with excavator/small crane depending on the weight. Small amount of scabbling works are still required for all piles to trim 50mm to cut off. This technique will not work on hooks/cogs.

Pile cropping will be undertaken by a specialist contractor in order to complete the works in the most efficient and safe manner. An alternative can also be using an excavator base pile cropping machine. Some concerns have been raised in the past as this has resulted in significant rework in the past, that could also negatively affect pile test outputs.

Pile cropping's will be disposed offsite to designated waste disposal waste tips (e.g. Eclipse Kwinana). Excavation waste due to the pile process will be temporarily stockpiled and reused as backfill within the embankment backfill. It will be subject to PSP test prior to re-use.



FIGURE 119 PILE CROPPING

16.5.14.2 Abutment FRP activities

Base is blinded prior to commencement of the Abutment base pilecap. Blinding thickness will be 50mm thick and will extend 1m beyond the base.

Pilecap base will be formed using conventional formwork, poured in a single pour. Concrete will be placed using a boom pump. In order to place base reo in a 25t Franna crane will be used. Starter bars will be installed at the locations of the proposed deflection and abutment walls. Starter bars will be secured to ensure that verticality is maintained during concrete placement. Access to the pour site will be via minor roads with local traffic controllers provided to control the delivery of trucks up to the boom pump. Traffic controllers will only be used on the day of the pour due to the large number of agitators in a relatively confined space.

Earthing a bonding testing will be undertaken prior to concrete pour to ensure to ensure earthing conductivity is maintained. Conductivity will be achieved by tack welding N12 bars around the perimeter.

16.5.14.3 L wall installation

16.5.14.3.1 L type retaining wall manufacture and delivery

- Panels will precast offsite in a precast yard to allow high quality finish to be achieved.
- Panels will be designed to retain 1.5m to max 6.5m height. They will also incorporate architectural feature in the face. A typical concept is shown in **Error! Reference source not found.** below.
- Precast panels will be steam cured to allow for early mould release
- Lifting anchor will be designed by specialist such as Reid's, to ensure that the panels can be lifted in a safe manner
- Widths of precast panels will vary (generally 2m and 3 m widths) as this will maximise efficient trailer use and site handling, and
- Retaining panel features integration of the deflection wall to avoid secondary pours as shown on below image. Furthermore, the other feature is the elimination of working at heights.



FIGURE 120: RETAINING WALL CONCEPT

16.5.14.3.2 Retaining Wall L Panel Erection

The taller panels that are approx. 35t will have to be on a 40t low level trailer, balance of the wall panels will be delivered via regular 24t trailer.

Lifting will be undertaken using a 170t all-terrain crane with a rope and sheave configuration. Panels will be lifted straight from the back of the trailer. A rope and sheath configuration will be used to lift the panel and erect into vertical position

Panel equipment requirement:

- 170t All terrain crane
- 1 x EWP to derig panel, and
- Crane operator and 3 men rigging team with working at height ticket.

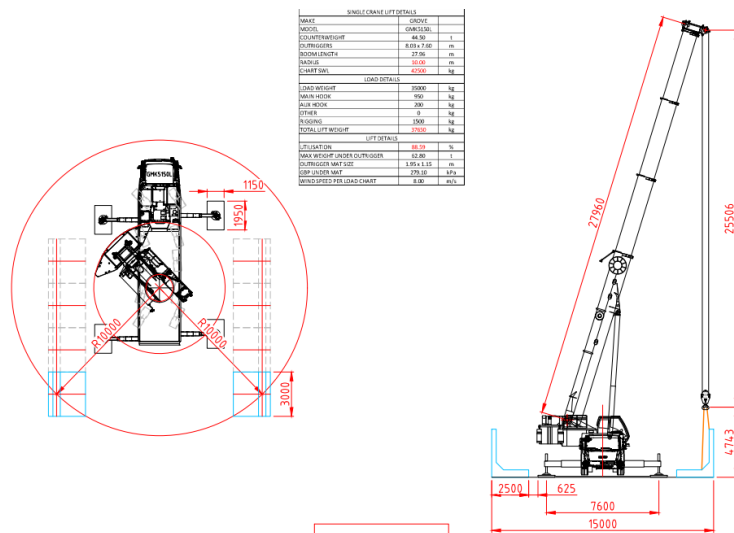

FIGURE 121: TYPICAL CRANE LAYOUT FOR PANEL ERECTION

Key steps associated with L wall precast panel installation is summarised below:

- Place 50mm sand bedding sand under the panel footprint. Level and check height.
- Place blinding between the panel bases, however leave out blinding pockets to allow for outrigger placement.
- Sequence of installation will be to work away from Abutments starting from East and then complete west. By completing the West wall last this allows for the maximum access working space for truck. Another reason that panels have to be installed working from Abutment is due to shear key presence.
- Panels will be delivered flat on the back with the return leg facing upwards. All trucks will need to be lashed as the temporary works lashing plan. ALUA will review and approve lashing design prior to delivery to site.
- Once into position panels will be installed using rope and sheave configuration and lifted directly of the back of the truck.
- Once erected, the rigging crew will gain access via EWP and derig the panels.
- Adjacent panels will be joined with some temporary bracketry (through top of panels) in order to ensure that panels are fully supported. In order to provide additional resistance to accidental impact during backfill temporary jumbo prop will be fixed to the back face of every 3rd panel. Jumbo prop will be fixed to the M16 ferrule from the back of the L wall panel and fixed to the temporary ground foundation. Temporary ground foundation will be a minimum fully buried 1m³ block.
- Permanent resistance to Retaining precast wall overturning will be provided via placing a L bar within the CMC pile in order to provide a tie in between the L wall base stitch pour and the CMC pile. The precast bar will be a N20 x 2m long with an 800mm L return into the RC stitch slab.

16.5.14.3.3 Retaining wall base stitch pour

Key steps associated with retaining wall stitch pour is summarised below:

- Once the Lpanel are erected, FRP activities will be performed associated with the base slab stitch.
- Forms will be constructed from traditional timber and ply formwork due to relatively low height of the foundation. Slab will be poured in 20m sections in a hit and miss configuration.
- Concrete will be delivered via boom pump. All curing will be chemical type spray on. Concrete agitators will be washed down in temporary washdown bays. Washdown bays will be prepared using Earthmoving equipment and will be HDPE lined. A windrow will be provided on 3 sides and a collection sump will be provided to allow surplus alkaline water to be disposed off site when unable to evaporate.
- Once installed the panels will be joint sealed from the earth retaining face. This will be done similar to typical WA bridges. Joint will covered with 200mm wide Bituthane 3000 (over bitumen primed face). Bituthane strip will be protected with a 300mm cement fibre sheet fixed over Bituthane 3000 with liquid nails to prevent damage during backfill.
- Patch all lifters, prior to backfill.
- Connect all earthing and bonding bars across the top.

16.5.14.4 Misc. Activities

16.5.14.4.1 Train deflection wall stitch pour

Once the retaining wall panel has been installed and the base stitch pour has been completed, the FRP crew will move onto the integrated train deflection wall as shown on image below.

The following steps will apply;

- Backfill embankment with conditioned select backfill
- Place backfill in minimum 300mm lifts, noting that within 2m face of retaining only DPU's can be used

- Undertake regular compaction testing until final lift is in
- Backfilling prevents the introduction of falsework and eliminates working at heights
- A formwork shutter will be prepared for back face. Front face will be part of the concrete wall and hence will be treated as permanent formwork. 16mm cast in ferrules will be cast into the front wall. This will be used as a tie back fixing.
- Reo will be placed in-situ. Reo bundles will be delivered via a city crane from ground level
- Once the reo fixing been finalised the back shutter will be installed. Tie bars will be placed through the shutter and fixed to the front ferrules.
- Pour the wall using a boom pump whilst ensuring that the concrete is vibrated.
- Strip the formwork and patch tie holes, and
- Chemically cure all the exposed stripped concrete surfaces.

16.5.14.4.2 FRP walls

Walls will be cast in multiple pours. A “hit and miss” approach has been adopted for straight wall shutters in order to minimise stop end construction. Multiple formwork crew will be engaged in order to expedite construction. It is envisaged that 1 formwork crew will be engaged on the outside retaining wall and 1 crew will work on outside wall and central deflection wall. RMD panelised formwork system will be employed. Wall shutters will be prefabricated on the newly completed slab to save on space as shown in Figure below.

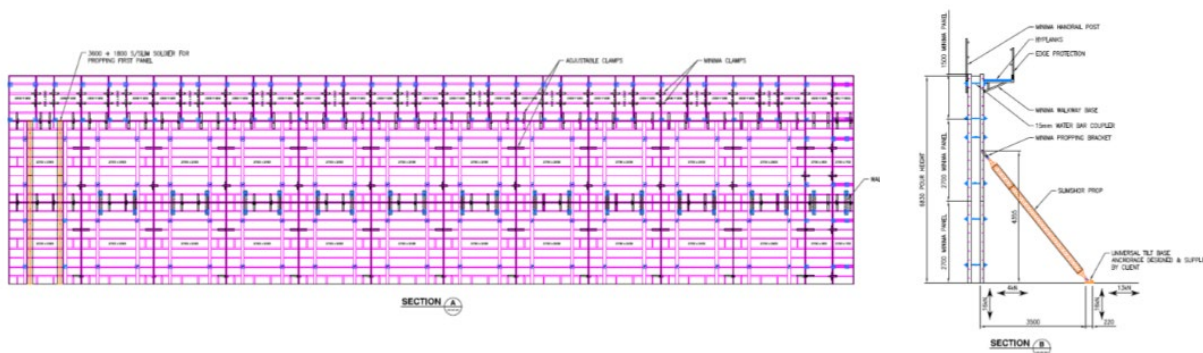

FIGURE 122: RMD FORMWORK SYSTEM

16.5.14.4.3 Retaining wall footpath and handrail

Upon completion of general backfill and service installation footpath installation will commence. Due to the very narrow width and constraints posed by the presence of the services trough and limestone hardstand, excavation box out will be undertaken with a 5t excavator with an 8 wheeler truck to support the excavator. Use of larger equipment will lead to unnecessary damage of completed concrete surfaces.

Edges against the limestone will be formed up and preferably saw cut to allow for “neat” surface tie in. Section of the footpath cast against completed concrete surface will be poured against “cell flex’ wrapped surfaces.

Concrete footpath will have a layer to 0.2mm film under the slab. Upon completion of the excavation, slab is to be compacted and verified by using a Perth Sand Penetrometer. Typical reading on 7 blows for 300mm layer will be deemed a past.

Concrete will be delivered via delivered via concrete agitator using the limestone hardstand to gain access to pour face.

Handrails and associated bolt cages will be pre-fabricated offsite. For ease of installation and handling they will be prefabricated in 3m length. Handrails will be Monowills type with 600 micron HDG to meet 60 year railing durability. Posts for handrails will be augured with a 5t unit with an auger attachment. A template will be used to maintain the correct position and alignment and bolts. It is anticipated that 200 lm of bored holes will be completed per shift. Each panel will be fixed with an earth tab which will be used to connect earthing cable to. Any damage to galvanising will be repaired using a zinc rich primer.

Where the embankment height is less than 3m, then a continuous external handrail will have to be installed. A temporary scaffold type handrail will have to be allowed for the full length prior to the installation of permanent handrail. Scaffolders will install the handrail once the backfill gets to 1 m of finished floor level to eliminate use of harnesses and static lines.

16.5.15 PSP Bridge construction (Not Applicable to DA 1)

16.6 Stations Demolition

The demolition scope includes all the stations and relevant facilities within the footprint of the new infrastructure as well as all the existing tracks and relevant equipment that will be replaced by the new viaduct.

Prior to any demolition commencing an asbestos survey will be carried out at each of the stations, and if required asbestos licensed removalist will be engaged by the demolition contractor.

A demolition permit will be requested for each station by the demolition contractor and specific methodologies and risk assessments will be produced by the contractor and reviewed by ALUA.

The schedule for demolition works is shown in the table below.

TABLE 11: SCHEDULE FOR DEMOLITION WORKS

Description of Works	Stage for Works
Oats Street – Existing Station demolition	Stage 6 – 3 weeks
Carlisle - Existing Station demolition	Stage 6 – 3 weeks
Welshpool - Existing Station demolition	Stage 6 – 3 weeks
Cannington - Existing station demolition	Stage 6 – 4 weeks
Queens Park - Existing Station demolition	Stage 6 – 3 weeks

The demolition works will be commenced as soon as the OLE cable is decommissioned.

The as noted above, Oats Street, Cannington and Carlisle will be demolished concurrently with Queens Park and Welshpool following shortly after.

All stations have existing assets that need to be salvaged and relocated to PTA’s storage depot. Prior to works commencing a schedule of assets to be salvaged will be provided to the demolition contractor and a site review will be carried out by ALUA to ensure clear understanding by the contractor. These assets will be removed using hand tools, protected, and relocated to the required location by the demolition contractor.



FIGURE 123: OATS STREET STATION TO BE DEMOLISHED (CARPARK DEMOLITION COVERED UNDER CIVIL SCOPE)

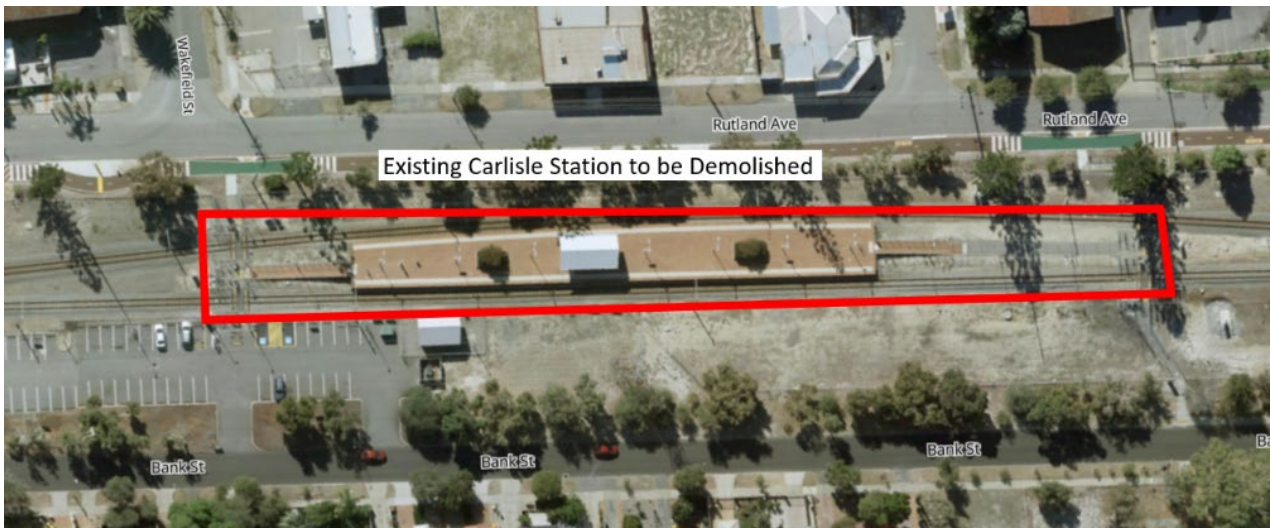

FIGURE 124: CARLISLE STATION TO BE DEMOLISHED (CARPARK DEMOLITION COVERED UNDER CIVIL SCOPE)



FIGURE 125: CANNINGTON STATION TO BE DEMOLISHED (CARPARK DEMOLITION COVERED IN CIVIL SCOPE)

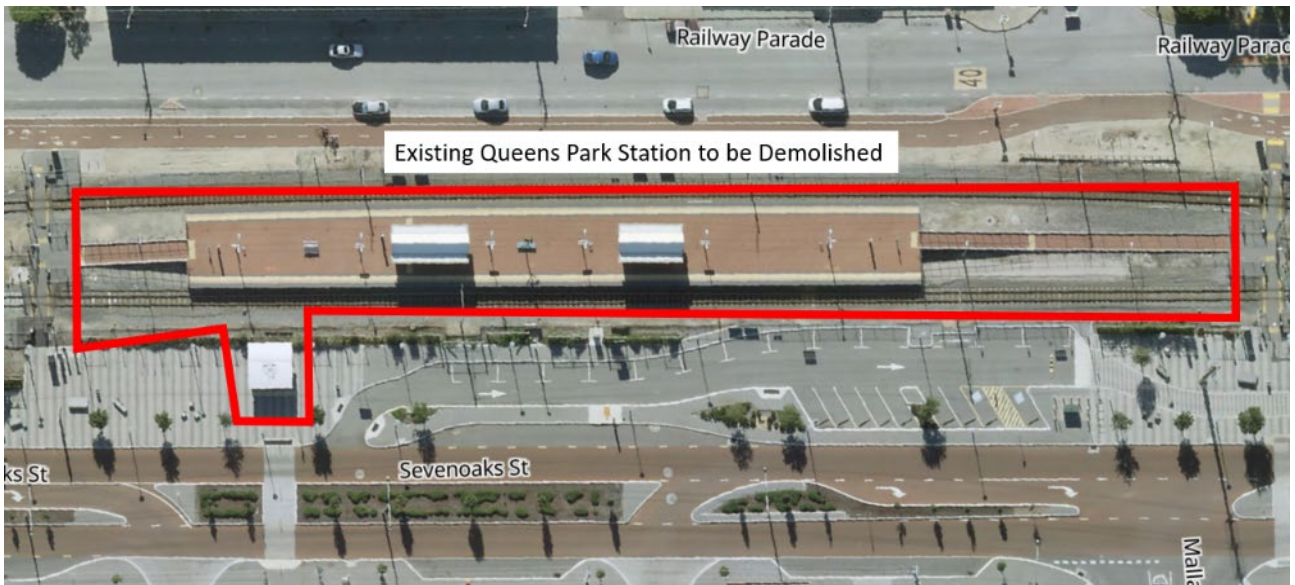

FIGURE 126: QUEENS PARK STATION TO BE DEMOLISHED (CARPARK DEMOLITION COVERED IN CIVIL SCOPE)

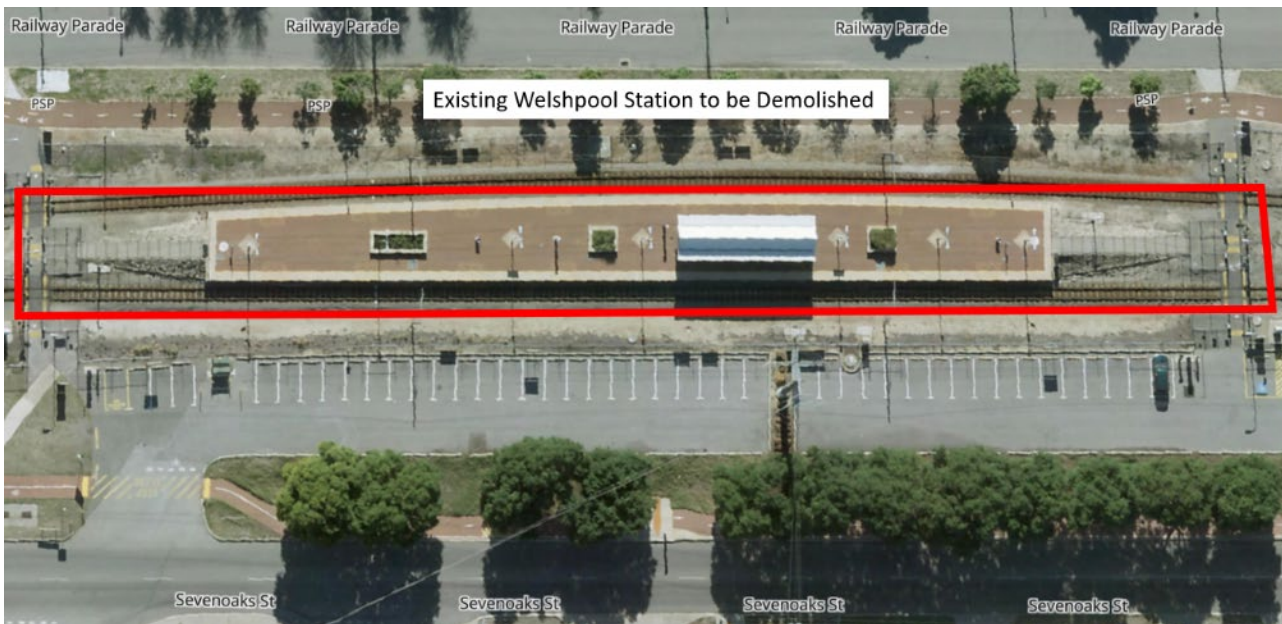

FIGURE 127: WELSHPOOL STATION TO BE DEMOLISHED (CARPARK DEMOLITION COVERED IN CIVIL SCOPE)

Where permanent demolition of infrastructure is required ALUA shall:

- Undertake the demolition work in accordance with AS 2601-2001: The Demolition of Structures.
- Provide a levelled site, free of depressions and undulations.
- Disconnect all services at the property boundaries in accordance with the requirements of the relevant service owners and Government Agencies.
- Cap all conduits and pipes at the disconnection points to prevent ingress of surface runoff and groundwater.
- Remove all structures, facilities, and debris above ground level.
- Remove all ground slabs, foundations, strip footings, pile caps, tanks and other structures below ground level excluding piles below pile cap level.
- Remove all demolished materials and debris from the site.
- Backfill all excavations with fill free of deleterious materials and compact to a density consistent with the surrounding ground.
- For backfill operations consideration shall be given to the local ground, groundwater and drainage conditions to ensure no adverse drainage effects.
- Recycle, to the maximum extent possible, all demolished materials to be removed from the construction site.
- Comply with all regulations, planning and authority requirements.
- Develop and implement a demolition method that minimises noise, vibration, and air quality impacts.
- Demolition works shall be carried out in accordance with the requirements of:
 - National Occupational Health and Safety Commission publication – “Asbestos: Code of Practice and Guidance Notes”
 - The Department of Occupational Health and Safety of WA Guidelines – “A Guide for the Safe Removal of Asbestos Cement Building Products”

- The National Occupational Health and Safety Commission “Code of Practice or the Safe Removal of Asbestos”
- Alliance Safety Management Plan including AGH HSE-OMR-008 Demolition.

Prior to any demolition, ALUA shall salvage and transport elements of value to locations nominated by the PTA. ALUA shall remove all demolished materials from the construction site, unless identified for retention. Demolished materials shall not be burnt or buried on the construction site.

The Alliance shall take appropriate measures to control traffic on public roads and to protect the general public from injury or harm when carting demolished materials.

The Alliance shall notify the appropriate Government Agency immediately on encountering hazardous materials or conditions including the following:

- Asbestos or material containing asbestos including asbestos cement products that have not already been identified.
- Flammable or explosive liquids or gases.
- Toxic, infective or contaminated materials.
- Radiation or radio-active materials.
- Noxious or explosive chemicals.
- Tanks or other containers which have been used for storage of explosive, toxic, infective or contaminated substances.

The Alliance will provide all warning signs, pedestrian deviation signs, temporary and security lighting.

Existing services, when encountered during the course of the demolition, will be treated in accordance with the relevant Third-Party Utility Providers requirements and shall be marked on the ground and recorded on drawings to be furnished to the PTA.

Any items that are not scheduled for demolition or are otherwise outside the required extent of demolition will be retained and protected from damage.

The Alliance will obtain agreement for relocation or disposal of flora and vegetation maintained by the Local Authority within the Project Activities.

Trees that are not identified for removal on drawings and that have not been authorised for removal by the PTA will be protected from damage.

Prior to decommissioning, salvaging or demolition works, the Alliance will undertake a HAZMAT survey of the stations and associated infrastructure within the limit of works. The findings of the HAZMAT survey will be used by the Alliance to develop a management process for any HAZMATs identified.

Plant to be used for demolition activities:

- Mobile crane
- 22-ton excavators with attachments
- Semi-tipper/bin truck
- Water cart
- Loader 924
- Lighting towers

Throughout all demolition activities, tipper trucks will be used to dispose materials off site and water cart to suppress dust. If night-time working is required, lighting towers will be used.

16.6.1 Stations Methodology (Not Applicable to DA 1)

16.7 Rail Systems

This section describes the construction of the rail systems being track, signalling, wayside communication and overhead line equipment.

16.7.1 Staging of Rail Systems

The enabling works, insofar as the rail systems discipline is concerned, are those activities required to meet the following goals:

- Install and commission a fibre optic cable between Cannington Station and Victoria Park Station to maintain continuity of communications services from the south to the north of the ALUA construction boundaries.
- Terminate the operational PTA railway at the ends of the ALUA work boundaries as a precursor to enabling demolition of the railway.
- Demolition of the redundant railway to clear the way for construction of the new ALUA railway.

The permanent railway is the construction of the new track, railway signalling (signalling), trackside communications (communications) and overhead line equipment (OLE) during the construction period. The permanent railway works also includes those activities required to commission and enter into service the new railway and integrate it into the existing operational PTA railway.

16.7.2 Enabling Railway Works

16.7.2.1 Trackside Communications

The railway communications work comprises the installation and commissioning of a fibre optic cable (FOC) between Cannington and Victoria Park. The scope of work for trackside communications is as follows:

- Installation of a conduit route that includes the following route features in addition to making use of existing railway signalling and railway communications cable routes:
 - Below ground pit and pipe route
 - Above ground HDPE conduit route
 - Underbores at road crossings
 - Underbores under track
- Installation of a new FOC into the route and cutting over the existing FOC services to the new cable route.

16.7.2.2 Enabling Works – Termination of the Railway

Within the enabling works for termination of the railway there are track, OLE, communications and signalling discipline packages. In summary the scope of enabling works is as follows:

- Convert Victoria Park Station to a terminus station that provides the PTA with functionality to turnback trains and operate a railway service between Perth Central and Victoria Park Station. This is achieved through modification of the existing signalling system and installation of train buffer end stops. Figure depicts the terminus arrangements in the vicinity of Victoria Park Station noting the signalling modifications occur between this location and the Victoria Park SER.



FIGURE 159: VICTORIA PARK TERMINUS

Following EIS of the Victoria Park Terminus the OLE wires will be removed from the anchor terminations (AT as shown in Figure 159). The masts will remain in place up to Miller Street bridge as will the rail and sleepers.

- Sever and secure the OLE wires to the south of Cannington Station as depicted in **Error! Reference source not found.**



FIGURE 160: OLE TERMINATIONS BECKENHAM

16.7.2.3 Demolition of the Railway

The existing railway is to be demolished between Miller Street bridge and Beckenham. Demolition of the railway requires deactivation of the signalling, OLE and stations communications systems prior to demolition. Demolition will commence at priority areas identified by the ALUA civil and structural disciplines before turning attention to removal of the railway in the most efficient manner.

The extent of demolition is as follows:

- OLE wires from CH5020 (Victoria Park Terminus) to CH11900 (Cannington Neutral Section)
- OLE masts and associated equipment from CH5350 (Miller Street Bridge) to CH11900 (Cannington Neutral Section)
- Track (rail, sleepers, turnouts, ballast and all other associated infrastructure) from CH5350 (Miller Street Bridge) to CH11900 (Cannington Neutral Section)
- Signalling (trackside and mounted equipment, location cases, signals, level crossing equipment and all other associated apparatus) from CH5350 (Miller Street Bridge) to CH11900 (Cannington Neutral Section).
- Trackside communications equipment (excluding the existing PTA radio towers, Carlisle CER, Cannington Relay Room and associated location cases and power supplies).

The scope of work for OLE demolition is as follows:

- Making safe the OLE system following deenergisation (and before working beneath) to avoid the development of dangerous stray currents.
- Removal of the elevated wires.
- Removal of the bracketry from the masts.
- Removal of mast mounted booster transformers and station mounted emergency supply transformers.
- Demolition of the OLE masts and foundations and backfilling.
- Removal of redundant materials to scrap or tip.

Lowering the OLE will require road sequenced closures of all of the level crossings between Mint Street and Wharf Street inclusive.

The railway signalling demolition scope of works includes the following:

- Make safe the redundant signalling system and railway level crossings by isolating power supplies and locking level crossings to the open position.
- Cataloguing and returning to the PTA of reusable equipment including railway signals, level crossing and pedestrian crossing equipment, trackside location cases and trackside signalling equipment.

Dismantling of the level crossing protection will require staged closures of all of the level crossings between Mint Street and Wharf Street inclusive.

Removal of foundations and bases by a general civil contractor.

Track demolition includes removal of the ballast, rail, fastenings, sleepers and turnouts and disposal as specified.

- Rails, sleepers fastenings will be removed from the sleepers and set aside for disposal as specified.
- Ballast removal will be by the ALUA civil discipline as part of the overall corridor reshaping.

16.7.3 Permanent Railway Works

There are significant works associated with the connection of the permanent railway alignment as described below. Staging of the permanent railway is generally in the following order.

- Civil construction of the permanent formation, railway embankments and viaducts as described in Section 19.5 and 19.5 in readiness for rail systems installation. Note that the following rail systems activities occurs during civil construction.
 - Installation of OLE foundations at ground level and on ramps and embankments as described in Section 19.8.5
 - Installation of OLE masts onto the viaduct piers as described in Section 19.8.5
- The TSERS and SERS are constructed as described in Section 19.7.2. The design of these rooms, and their placement within the station, enables them to be completed even when the station itself has not been completed. These rooms are fitted out with building services and made ready for signalling and communications apparatus installation.
- All TSERS and SERS (located within the stations in the instance of Carlisle, oats Street, Queens Park, Cannington and Beckenham, and outside the stations for the Cannington SER and Welshpool TSER) are required to be installed and fitted out with signalling equipment in order to enter the new railway into service.
- In regard to the station and building works, the signal and communication rooms are required to be fitted out and entered into service when the new railway is entered into service. If a particular new station is not entered into service at the same time as the permanent railway these equipment rooms are nonetheless required to enable commissioning of the entire signalling and communications system.

16.7.3.1 Miller Street Tie-in

With the Victoria Park Terminus implemented the new railway can be constructed in final position and connected to the existing railway as depicted in Figure .



FIGURE 161: MILLER STREET TIE-IN

16.7.3.2 Beckenham Tie-in

The tie-in at Beckenham can be constructed in final position as depicted in Figure 162.



FIGURE 162: BECKENHAM TIE-IN

16.7.4 Track Construction

16.7.4.1 Key Material Supply and Storage

The track structure consists of the following type-approved products:

- 60mm railway ballast
- Concrete sleepers with E-Clip resilient fastening assembly
- 60kg rail

Sleepers will be delivered to site and stored along the corridor, clear of the access track. Rail will be delivered to site in 27.5m lengths. Approximately 22 tonnes can be transported to site on semi extendable truck transport, which defines the following quantities per delivery:

- 88 x NG concrete sleepers per delivery
- 12 x 27.5m lengths of 60kg rail.

Materials will be received along rail corridor for the temporary track before being incorporated into the railway. Laydown areas have been identified and will be developed at the abutments for ferrying onto the elevated railway. Materials will be brought to site on a just in time basis.

Materials will be stored in a manner that ensures degradation does not occur. Specific storage methods are as follows:

- Rails (including turnout, plain and special rails) will be stored on firm ground, in an upright position and supported off the ground on dunnage places at regular intervals to avoid undue sagging.
- Sleepers will be stored in low and tidy stockpiles, supported off the ground and between layers by sleeper dunnage.
- Ballast will be stockpiled on a hardstand. Care will be taken when drawing from the stockpile to ensure it is not fouled during handling.

- Turnout components such as point motors will be stored under cover in a dry environment.

16.7.4.2 Ballasted Track Construction

Ballasted track is required at the following locations:

- Temporary railway alignment locations.
- Track on embankments.

This section describes the process of constructing ballasted track.

16.7.4.2.1 Survey Setting Out

A surveyor will be used to set out the design track centreline (offset to running edge or centreline) and top of design rail (low rail around curves), at approximately 10m centres through straight sections, and 5m around curves. The surveyor also provides data for use by the track geometry alignment system within the ballast tampers.

16.7.4.2.2 Rail Handling Welding and Destressing

Rail will be delivered to Kewdale Freight Terminal in 27.5m lengths (length hot rolled to size to assist transportation method via road). It is then direct loaded onto semi-extendable trucks and escorted to site during MRWA compliant delivery hours (9:00am – 3:00pm). Rail will be delivered to the formation and stockpiled locally at discrete laydown areas in the corridor.

During track construction, rail is threaded into position in 27.5m lengths and flash butt welded on site, in-situ with a mobile flash butt welder. Destressing is done in up to 330m module lengths with weld crews in-situ clipping up at neutral temperature. End joins will be clamped with fishplates.

Post tamping, weld crews will use conventional welding techniques to complete the final adjustment welds at the fish-plated joins, centrally to destress module.



FIGURE 163: MOBILE (HIRAIL) FLASHBUTT WELDER IN OPERATION

16.7.4.2.3 Bottom Ballast Installation

Once the capping layer has been tested for compaction requirements, bottom ballasting can commence. Bottom ballast will be placed and spread one track at a time, placed 50mm low, to accommodate a 50mm tamping lift. The bottom ballast will therefore be laid at a 200mm thickness.



FIGURE 164: BOTTOM BALLAST ROLLED AND READY FOR SLEEPER PLACEMENT

16.7.4.2.4 Sleeper Laying

Concrete sleepers will be laid with a 20-24 tonne excavator or 15 tonne Hi-Rail Excavator with an Octopus



FIGURE 165: SLEEPER PLACEMENT USING OCTOPUS GRAB

attachment at 80 sleepers per hour with two Volvo Front End loaders and fork attachment, feeding the excavators concurrently.

16.7.4.2.5 Threading and Clipping of Rail

Once the sleepers have been placed on the new track alignment and squared, a Hi-Rail Excavator will thread the new 60kg rail over the rail seat of the concrete sleeper. The rail will be threaded in preparation for flash butt welding.



FIGURE 166: THREADING

16.7.4.2.6 Top Ballasting, Ballast Tamping and Regulating

Upon flash butt welding of track, top ballasting can occur. The skeleton track will be flooded with ballast to top of rail, in preparation for surfacing activities. Top ballast will be stockpiled at discrete locations, site compound locations and primary land acquisition areas. The method of top ballasting will be via Front End Loaders.

In order to be in a position to bring the newly constructed track into operation at the completion of the final possession all plain line track constructed prior to the possession must be tamped and surfaced prior to the start of the possession, leaving only the tie-ins to be completed in the possession.

Pandrol Jackson and/or Plasser Tampers will be used to tamp the track during normal working time conditions for Midland line. The tamper and supporting regulator will be craned onto location by a 130 Tonne mobile crane which will also transfer them between tracks where turnouts are not available to do so. Following each entry into service the tamper and regulator will need to be stabled off site. The tampers will track travel to a suitable siding within the network (location to be agreed with PTA) or will exit the network on-rail.

Where track surfacing occurs in the vicinity of signalling equipment the fleet will be accompanied by a signalling technician. Similarly, where other track equipment obstruct machine work a suitably competent worker will be present to relocate or protect that equipment.

Follow up tamping will be conducted after entry into service as required.

16.7.4.2.7 Destressing

Once the track surfacing has been completed the rails will be destressed to achieve, the specified neutral temperature. The destressing modules are planned to coincide with remaining free welds and to consider the destressing requirements during possessions and extension into existing track.

16.7.4.2.8 Rail Profile Grinding

After welding, surfacing and destressing has been completed the rail will be profile ground using a production rail grinder. The staging of rail grinding is as follows:

- For the temporary track a plain track production rail grinder will grind the rails following entry into service. Grinding will occur during a series of after last / before first shutdowns supported a track and signalling team to remove rail infrastructure such as signalling equipment from harm's way.
- For the permanent railway a rail profile grinder capable of turnout and plain track grinding will be mobilised to grind prior to EIS of the permanent railway. Mobilisation will occur on a just-in-time basis and the grinder deployed to grind the tie-in interfaces as the final grinding task.

Where rail grinding occurs in the vicinity of signalling equipment the fleet will be accompanied by a signalling technician. Similarly, where other track equipment obstruct machine work a suitably competent worker will be present to relocate or protect that equipment.

Where rail profile grinding occurs in the vicinity of signalling equipment the fleet will be accompanied by a signalling technician.

16.7.4.3 Track Construction on Viaduct

This section describes construction of the track slab on the viaduct.

16.7.4.3.1 Access to the Elevated Railway for Track Construction

Management of materials onto the viaduct for construction requires careful consideration and will generally be undertaken by the proven method described in Figure 167.

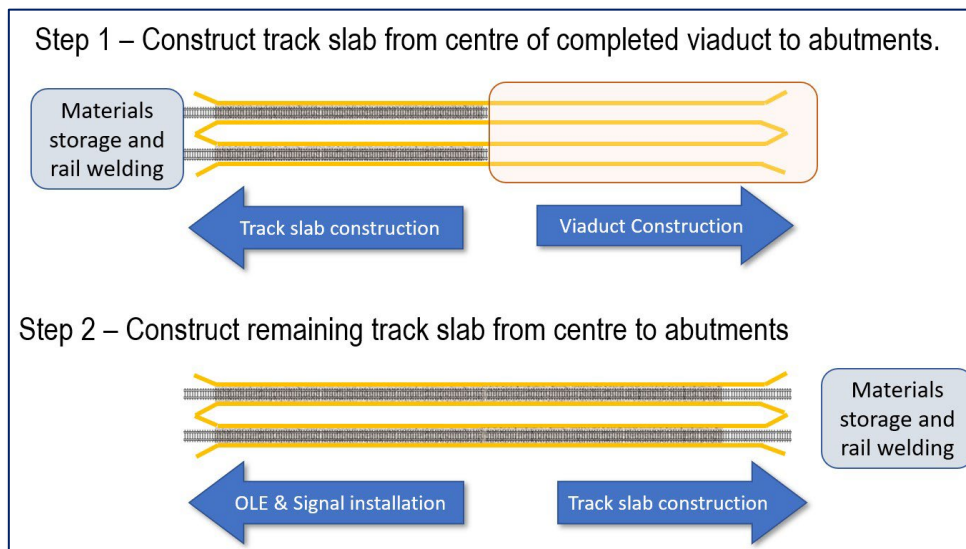

FIGURE 167: VIADUCT TRACK CONSTRUCTION LOGISTICS

Access onto the viaduct is constrained due to limited accessibility from ground level. The access and construction strategy described below is based upon the principles of working from the centre between access points and working towards the access point. The viaduct superstructure will be built from north to south and the tracklaying on the viaduct will generally follow in series.

- Package 1
 - Access is available at CH5400 NORTH, CH7400 MIDDLE and CH8400 SOUTH.
 - New Carlisle Station is at CH5912 to CH6062
 - New Oats St Station is at CH6884 to CH 7034
 - From access CH5400 we will distribute rail and slps from nominal CH6884 to CH5400 (basis: not to drag rails past the Oats Street Site).
 - Then tracklaying will occur from CH6884 to CH5400.
 - From access CH7400 we will distribute rail and slps from nominal CH6884 to CH7400.
 - Then tracklaying will occur from CH6884 to CH7400.
 - From access CH8400 we will distribute rails and slps from nominal CH7400 to CH8400.
 - Then tracklaying will occur from CH7400 to CH8400.



FIGURE 168: RAIL CONSTRUCTION SITE

- Package 2
 - Access available at CH8700 NORTH and CH11200 for the Cannington viaduct.
 - New Queens Park is at CH9851 to CH10001
 - New Cannington Station is at CH10765 to CH10915
 - New Beckenham Station is at CH12091 to CH12241
 - From Access CH8700 we will distribute rail and slps to CH9950 to allow Cannington uninterrupted time for construction.
 - Then tracklaying will occur from CH9950 to CH8700.
 - From access CH11200 we will distribute rail and slps CH9950 to CH11200.
 - Then tracklaying will occur from CH9950 to CH11200.

16.7.4.3.2 Track Slab Construction

Track slab will be constructed within the viaduct structure.

- Flashbutt Weld rails at the ends of the abutments (at ground level) from short rails to nominal 110m at a static FBW site established for this purpose.
- Scabble to viaduct base ready to accept the track slab.
- Drag up onto viaduct with L120 FEL or similar and position on outer inside edge of viaduct.
- Ferry concrete sleeper blocks onto the viaduct in bundles.
- Lay sleeper blocks and place rail on sleepers. Clip up 110m panels and fishplate the ends.
- Protect the rail and sleeper plates from concrete splatter using bespoke covers.
- Install shear bars for the track slab as specified.

- Lift and line the rails to final line and level.
- Using a bespoke mobile form, form and pour the track slab and derailment containment walls and allow to cure. Brace the form against the viaduct walls. Construct construction joints as necessary.
- Pour fibre reinforced concrete and allow to cure.
- Resurvey the rail and compare with design. If changes are required due to beam settlement and/or other movement.
 - Remove the screw spikes and shim under the rail using industry standard packers to achieve design top of rail level.
 - Use the horizontal adjustment within the sleeper plate to achieve horizontal alignment.
- Clean up and make good the viaduct.
- Install expansion joints.
- Destress the rails.
- Make ready for signalling and viaduct installation.
- The above process is depicted in Figure .

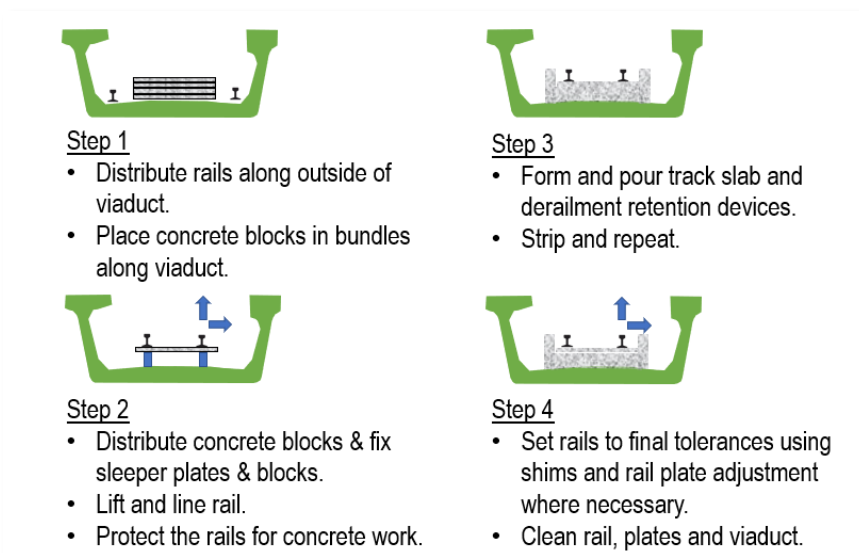

FIGURE 169: TRACK SLAB CONSTRUCTION STAGING

16.7.4.4 Turnout and Crossover Construction

Turnouts and crossovers will all be built in-situ, in the final location in track. The final design arrangement of the turnouts consists of 1:12 turnouts on precast concrete bearers. The following components will be assembled by rail crews assisted with suitable equipment:

- V-Crossings, stock rails (curved/straight), switchblades, guard rails, closure rails
- Huckbolts, pandrol cast plates, heel plates, crossing plates, Pandrol e-clips, HDPE rail pads, M24 bolts/nuts/spring washers concrete bearers, cant reducing bearers.

Once the turnout has been assembled and track surfaced the points motor and rodding will be installed by suitably competent mechanical points fitters and the points motors connected to the relevant LOC cases.

16.7.4.5 Formation Renewal

Formation renewal occur (as per the specification) where the track slew or lift exceed specified parameters and typically occurs where new track ties into existing track. This works occurs during shutdowns and as such the shutdowns will include sufficient time and resources to conduct reconstruction of the underlying formation using the following methodology:

- Identify the extent of formation renewal arising from track realignment.
- During a shutdown:
 - Remove the track overlying locations of formation renewal.
 - Remove the existing ballast and excavate to the specified lines and levels.
 - Place and compact capping material.
 - Replace the overlying track and connect to the surrounding railway.
 - Lift, line and weld the track to completion.
- Destressing may occur post shutdown subject to time availability during the shutdown.

16.7.4.6 Special Rails & Rail Dampers

There are a number of “special” rails required to be installed as per the designs.

- Rail expansion joints.
- Insulated Rail Joints

These are welded into track at the appropriate location prior to track surfacing.

Rail dampers will be installed in coordination with rail welding, rail grinding, track surfacing and the other intrusive track construction activities.

16.7.4.7 Buffer End Stops

Buffer end stops will be assembled insitu after completion of the track surface. Upon mechanical assembly any necessary signalling aspects will be installed to the buffer.

16.7.4.8 Demolition of Redundant Track Equipment

When track is made redundant it is demolished as follows:

- Rails are cut into manageable lengths set aside for transport.
- Fastenings are gathered and set aside for transport.
- Sleepers are gathered in bundles along the railway corridor in preparation for transport.
- Turnouts and other special rails and track components are similarly gathered.
- Cataloguing and returning materials to client nominated locations.

Materials deemed unsuitable for reuse by agreement with the client will be disposed of with an emphasis on recycling before disposal. The construction processes for demolition will complement the requirements of the Commissioning Plan for decommissioning.

16.7.4.9 Temporary Level Crossings

In the event that temporary level crossings are required in the greenfields construction site the sequence of works is as follows:

- Apply geotextile fabric to the top of the sleeper and ballast to protect from debris ingress.

- Place clean fill material on top of the geofabric and shape the approaches to make ready for the intended road traffic.
- Install appropriate temporary crossing protection (e.g. temporary boom gates, barriers and/or signage instructing the user in the use of the crossing).
- Advise the railway safeworking coordinator of the crossing location for coordination with rail movements across the greenfields site.
- Monitors and maintain the level crossing surface.

When the crossing is no longer required it will be removed and the underlying railway made good.

16.7.4.10 Grinding, Maintenance Tamping and Track Geometry

New running rails will be ground to the profile as defined in the specification with an appropriately accredited mainline rail grinding machine. It is anticipated this would be scheduled to be undertaken once all new tracks are completed.

Track geometry will also be checked and recorded for gauge, cant and twist, and compliance to design alignment, upon completion of construction works.

16.7.4.11 Testing and Commissioning

Testing and commissioning of track involves the completion of relevant quality documents including the following:

- Material compliance – collation of relevant materials certifications for sleepers, rail, ballast turnouts and other components.
- Construction compliance that demonstrate proper assembly of track materials, conformation that rail geometry complies with the specification and rail grinding achieves the required tolerances.
- Clearances checks at key locations such as platforms and other critical areas.

These documents are prepared by the track installation team and presented to the Commissioning Manager in preparation for entry into service.

16.7.5 Overhead Line Equipment (OLE)

This section describes the practices for construction and testing of the OLE system.

16.7.5.1 Material Management

Materials will be brought to site on a just in time basis and stored in a manner that ensures degradation does not occur. Specific storage methods are as follows:

- Materials such as masts and mast equipment will be stored on firm ground and separated by dunnage.
- Expensive materials such as wire will be kept safe offsite until immediately before installation.

16.7.5.2 Construction

The OLE system infrastructure requires two distinctly installations. OLE structures using bored foundation are installed at ground level and on embankments and are depicted in Figure 170. OLE foundations will be installed in tandem with formation earthworks (prior to track construction) to make best use of available construction space.

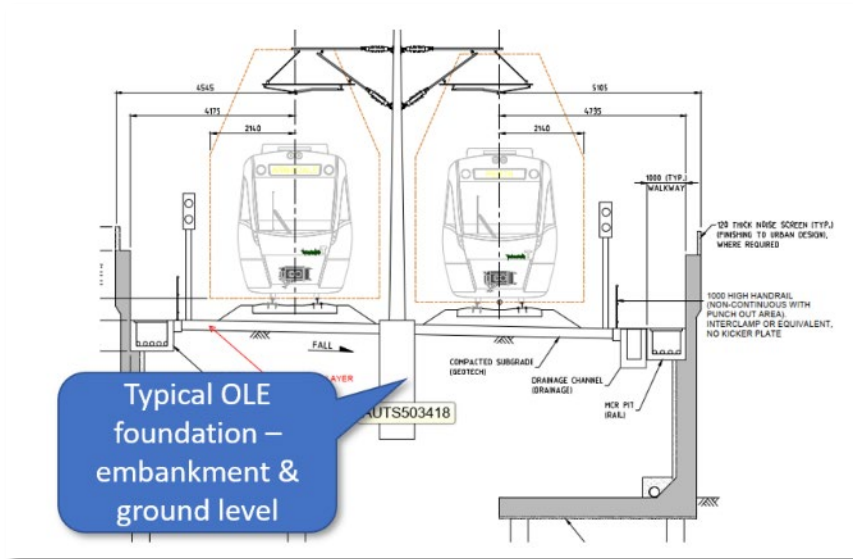

FIGURE 170: TYPICAL OLE FOUNDATION - GROUND LEVEL & EMBANKMENTS

OLE masts along the elevated viaduct are connected to the piers as depicted in Figure . These will be installed progressively as the viaduct is erected.

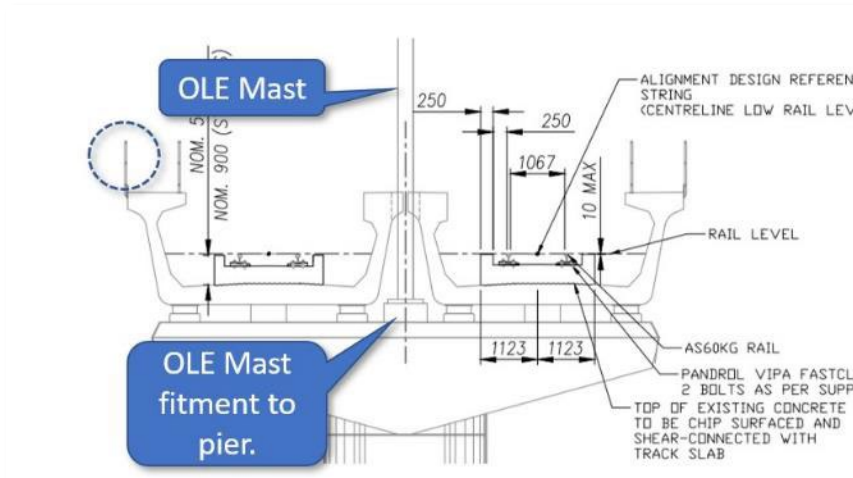

FIGURE 171: OLE MAST INSTALLATION - VIADUCT

Cantilevers and other mast fitments will be assembled at site under cover of a suitable temporary workshop before being incorporated into the works. Installation and dressing of the masts, including small part steelworks installation, will kick-start installation after the track installation crew completes the offline track works. This will ensure work progresses in a linear fashion, without delays.

Final OLE Stringing, registration, sectioning equipment and earthing and bonding work will be installed where the site access is permitted.



OLE installation during green field construction will only include true greenfield areas, to maintain isolation of operational areas from construction areas. These zones will be completed during the cut over closures when the whole greenfield area becomes energised.

FIGURE 172: OLE INSTALLATION

Non-electrical testing and commissioning includes continuity test (Ductor), joint site inspection and pantograph run will be carried out with the witness of client engineers to confirm the integrity of OLE installation. OLE installation defects picked up by the non-electrical testing and commissioning to be rectified and completed prior to OLE energisation following each closure.

16.7.5.3 Demolition of Redundant OLE Equipment

The existing OLE system is demolished when made redundant. Key considerations in demolition this equipment are as follows:

- Demolition will occur during track possessions (especially where tie-ins on exiting to new track occur) or as a greenfields site once the OLE is made redundant.
- Wires are brought to ground by disconnecting at the extremities of a length. Where wires may fall across a roadway or other vulnerable area the rail may be temporarily anchored to permit bringing to ground under controlled conditions during a closure of the area.
- Cantilevers and other OLE equipment are scrapped or returned to the PTA as per the specified requirements.

Concrete mast removal will be carried out by suitable qualified Class 1 demolition contractor and the following methods:

- Loader and rock breaker will be utilised for redundant OLE concrete mast and foundation removal. With the assistance from on-track EWPs, concrete mast is supported by loader approximate 2/3 from the top of the mast while rock breaker will induce force to concrete mast near ground level to break concrete component of the mast.
- Then, pre-stressed strand and earth core will be cut off by grinder.
- Then rock breaker will remove the remaining mast and foundation down to specified levels underground unless otherwise instructed. If protruded concrete mast and reinforcement are not removed immediately, sharp edges shall be sprayed with pink paint and covered against personnel by putting traffic cone or similar onto the protruded section.

Materials recovered from temporary track arrangements remain the property of ALUA and will be scrapped accordingly. The construction processes for demolition will complement the requirements of the Commissioning Plan for decommissioning.

16.7.5.4 OLE Testing and Commissioning

16.7.5.4.1 Phase 1 – Pre-Commissioning

Commissioning Engineer shall ensure the following prior to final commissioning inspection and testing:

- Ensure that all Commissioning Team is briefed of the commissioning activities.
- Ensure that all ITPs produced are reviewed and accepted by the PTA Representative.
- Ensure that all design specifications and Issued for Construction (IFC) drawings as well as red marked IFC drawings are available for inspection acceptance by the commissioning team.
- Ensure all verified and signed off installation ITPs (OLE installations including masts foundations) are available for inspection by the commissioning team
- Height and stagger checks at supports and at mid-span.

- Checks on the setting of tension weights and pulleys.
- Checks on conductor tension including earth wire, return conductor and mid-point tie wire
- Checks on the position and level of terminations/anchors.
- Checks on wire separation of return conductor and earth wire crossing above the catenary/contact wires with respect of the temperature.
- Checks on electrical and mechanical clearances; and
- Any other tests and checks to verify the correctness of the OLE installation.

16.7.5.4.2 Phase 2 – Non-electrical Static Verification (Joint Site Inspection)

The Commissioning Engineer shall carry out the installation inspection with the Commissioning Team. The inspection check will include the following:

- Location, track ID No, mast ID and isolators ID
- Height and stagger checks at supports and mid-spans. Sample checked against the installation ITPs. Settings of tension/balance weights and pulleys. Sample checked against the installation ITPs
- Visually check that Return Conductor (RC), Earth Wire (EW), Mid-point tie wire, Catenary and Contact wire are not out of place. Sample check will be carried out against relevant installation ITPs prior and during the shut
- Check on mechanical and electrical clearances in critical areas, which are shown on height and stagger record sheets. - Level/height and clearance check where RC and EW are crossing 25kV equipment
- Level/height and clearance check on anchor/termination of Earth Wire Anchor (EWC), Balance Weight Anchor (BWA), Mid-Point Anchor (MPA), Return Conductor Anchor (RCA), and Fixed Anchor (FA) Cantilevers (visual inspection against ITP)
- Earthing and bonding shall be visually inspected to ensure all installations are in accordance with Earthing and Bonding Design Plans
- General workmanship checks to verify OLE equipment has been installed in accordance with the PTA guidelines and procedures
- Specification for Earthing and Bonding in the 25kV AC Electrified Areas Doc No. 8140-900-677
- Code of Practice for the Design, Supply, Construction and Commissioning of 25kV Traction Overhead Catenary Equipment Part A Doc No. 8190-800-001
- Code of Practice for the Code of Practice for the Detailed Material Specification Doc No. 8190-800-006.

The PTA Representative shall be present during all of the site joint inspection and testing activities. Ensure that all Commissioning Team is briefed of the commissioning activities.

16.7.5.4.3 Phase 3 – Non-electrical Dynamic Verification (Pantograph Inspection Run)

A series of running tests shall be performed using a track vehicle fitted with a measuring pantograph similar to the rolling stock pan profile and pressure. The Commissioning Engineer shall ensure the objectives of the test as follows are met:

- Lateral running of the contact wires, to check and verify the contact performance between pantograph and contact wires.
- Stagger and height of the contact wires when uplifted, to check and verify the heel setting and stagger matches the pantograph profile.
- Random checking of components, to check and verify the satisfaction of the systems in component level

- Convergence or divergence of contact wires (turnouts), to check and verify the contact wires running within the pantograph profile.
- Clearance at double cantilevers and between crossed catenaries (overlaps), to check and verify the dynamic electrical clearances.
- Contact performance between pantograph and contact wire and section insulator will be observed to ensure correct installation/operation.

The overhead installation contractor will provide staff to assist in inspection activities and if time permits, to carry out all rectification work. The commissioning team shall agree and compile a list of remaining non-operational critical defects to be rectified as soon as practically possible.

16.7.5.4.4 Phase 4 – Electrical Commissioning Test

- Section Proving Tests – Energisation

Section Proving Test shall only be carried out upon satisfactory completion of the above-mentioned Insulation Tests and approval from the PTA Representatives. These tests shall be undertaken under PTA control with the Traction SCADA fully operational.

- Power-on Tests – Energisation

PTA shall energise the OLE to enable visual and audible verification of the overhead section prior to opening the section to train services.

- Trial Running (Train Test)

Passing of the first test train will be observed by the commissioning team in order to determine sparking absence and satisfactory current collection.

16.7.6 Signalling, Communications and Control Systems Construction

This section describes the practices used for construction of the signalling and communications system.

16.7.6.1 Methodologies

The proposed Signalling System design and implementation will ensure minimal risk is encountered in the construction and integration to the existing PTA signalling system by applying existing designs and approaches, in compliance with the SWTC and latest PTA standards and specifications wherever practicable.

Signalling and communications works are undertaken using industry standard practices that include:

- Pit and pipe construction for local cables and the main cable route.
- Pulling of cables.
- Installation of location case, level crossing boomgate and other trackside equipment bases.
- Wiring and cabling of trackside equipment and equipment within equipment rooms.
- Mounting of cable containment within the station building, equipment rooms and along the viaduct.

The MCR will be installed into a tray mounted to the support frame for the architectural screen. The process for installation will generally be as follows.

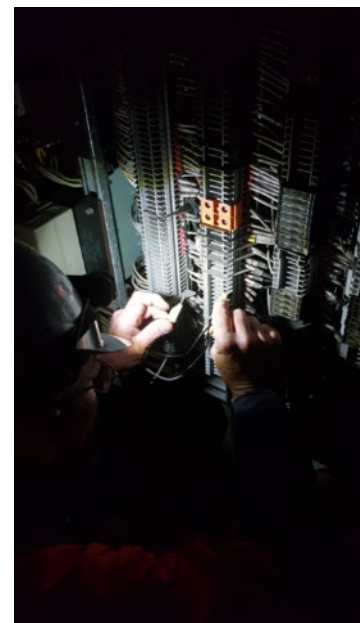

FIGURE 173: SIGNALLING

- Assemble troughing onto barrier on ground (subject to stability check).
- Install continuity bonding to tray.
- Install lids onto tray.

Signal, communications and power will be installed into the tray as per the cable schedule and delivery programme. Transitioning of cable containment from the tray to the stations or to ground level troughing will be in accordance with the relevant detailing, as will local cabling to the trackside signalling equipment.

16.7.6.2 Temporary Signalling Arrangements

This section describes the temporary trackside signalling work required to facilitate delivery of the project.

16.7.6.2.1 Temporary Signalling Arrangements

For the full closure scenario the temporary signalling arrangements comprise changes to Victoria Park Station to prepare it for operations as a terminus which includes the following works:

- Installation of additional signals to enable terminus operation including associated location case, equipment room and local cabling works. These works will occur during a series of extended overnight shutdowns.
- Installation of buffers stops on both the up and down mainlines (to the immediate south of Victoria Park Station) and the fitment of red aspects. These works will occur during a series of extended overnight shutdowns.
- Entry into service of the terminus arrangement including a train control system update to enable the terminus movements. These works will occur during a weekend 56 hour shutdown that is contiguous with the extended railway closure.

The works will be undertaken using conventional methods, with testing performed at the respective stages in anticipation of the commissioning and EIS processes.

16.7.6.3 Temporary Communications Arrangements

This section describes the temporary trackside communications work required to facilitate delivery of the project.

16.7.6.3.1 Temporary Communications Arrangements

A temporary fibre optic cable pit and pipe route will be constructed and joined to the existing main cable route.

Fibre optic cable will be installed to the extents shown in Table 20.

TABLE 12: TEMPORARY FOC

Section	Start CH	Finish CH	Total (m)
Vic Park - Carlisle - RRP	3940	6030	2090
Carlisle - Welshpool RS - RRP	6030	7760	1730
Welshpool RS - Cannington Temp RR - RRP	7760	10970	3210
Cannington Temp RR - Cannington SER - RRP	10970	11170	200
Cannington SER - Beckenham SP - RRP	11170	12160	990

16.7.6.4 Third Party Fibre Services

As PTA have referenced in RFI 00054 Vocus uses 6 cores out of PTA’s backbone which is part of a wider fibre sharing agreement between Vocus and PTA. Vocus do use these cores and therefore they must be maintained through the duration of the works.

ALUA have discussed the matter with Vocus who understand that the MCR needs to be shifted and that will require a shutdown of the cable. They will allow a 6-8 hr window at night for the switch from one cable to the other. They will require sufficient notice of the switch so they can provide advanced notice to their customers.

In regard to the FAL fibre return path, PTA are using Vocus’ fibre to connect between the Armadale line at Welshpool and the new FAL line. This again is under the fibre sharing agreement but in this instance PTA is using Vocus’ fibre. PTA Addendum 3 states that this cable needs to remain operational for the duration and ALUA will connect it to the temp MCR then again to the permanent MCR.

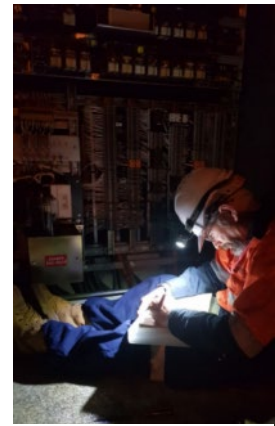

FIGURE 174: FIBRE SERVICES

16.7.6.5 System Updates

The following system updates are required.

TABLE 13: SYSTEM UPDATES

Stage	Events	System Updates
1	OLE foundation and signalling underbores works vicinity Victoria Park Station. Temporary FOC underbores Carlisle to Beckenham.	None
2	OLE foundation and signalling underbores works vicinity Victoria Park Station. Temporary FOC underbores Carlisle to Beckenham (continues).	None
3	EIS Victoria Park Terminus. Enabling for demolition of existing Carlisle, Oats Street, Welshpool, Queens Park, Cannington and Beckenham Stations Enabling for temporary bus interchanges at Oats Street and Cannington.	TCS update for EIS Victoria Park Terminus. OT updates for station closures and other SCADA changes.
4	Full closure for construction of the new railway.	None.
5	EIS Viaduct and new Stations (~15 months)	TCS update for EIS new railway. OT and other SCADA updates for EIS new stations and railway.
6	Driver training (~3 months)	None.
7	Follow-up tamping	None.

16.7.6.6 Demolition of Redundant Signalling and Communications Equipment

Once made redundant, the existing signalling equipment will be demolished and recovered in accordance with the specifications.

- Trackside signalling components will be catalogued and returned to the specified locations.
- Redundant cabling will be treated as per the requirements of the SWTC.
- Equipment associated with the temporary signalling system remains the property of ALUA.

The construction processes for demolition will complement the requirements of the Commissioning Plan for decommissioning.

16.7.6.7 Key Considerations

Several key technical items will be addressed through design, supply and fabrication activities to support the delivery of a safe, reliable and consistent signalling and communication system including the following:

- Considering PTA Technical Instruction TI-044 ensure that all new Microlok PBI and Frauscher axle counter evaluators will be housed in a Standalone Equipment Rooms (SER) or Trackside SERs (TSER) only for management of equipment environmental factors.
- The SER will have sufficient space to house all Signalling equipment within the vicinity and will be positioned to ensure for optimal trackside equipment coverage without the requirement for additional TSER sites to maintain overall value for money.
- Related cable runs for equipment serviced by the SER (such as ATP transponders, axle counter evaluators, signal heads and similar) will be assessed to ensure no dangerous earth potential rise is generated with due consideration to the impact of a 'boosterless' overhead traction power system and the overall project Earthing and Bonding plan. An EMC Induction Assessment will be completed during the design stage to ensure induced voltages remain below specified safe levels.
- Consideration of SER location to avoid increased exposure to a potentially unsafe working environment for PTA maintainers, including access in raised formation locations and inclusion of suitable barricading and bollards to protect both people and infrastructure.
- Once MCR and related cable route works are completed, early communication system works will include the installation of new main optic fibre cables in the new MCR, replacing those that will be in abandoned sections of the existing MCR. All communication back-bone system testing and cut-over will occur ahead of, and in a separate commissioning activity to any signalling system enabling works and related commissioning to ensure it is ready and available to support the signalling system staging.
- Installation of signal cabling, SER and TSER will occur in parallel with track and OHLE construction, to allow for physical connection into the new systems. The SER and TSER will be factory constructed, bell tested and where possible, function tested to ensure site works will be as low risk as possible.

The signalling staging design will account for the track staging. Each stage design will be completed with the same process and rigour as for a final implementation to ensure compliance with all requirements from PTA's technical procedure for Signalling Design, document 8110-600-001. This process will include addressing safety related application conditions (SRAC) and input to system assurance processes related to Rail Safety National Law and related safety case so these can be reviewed and approved prior to commencement of applicable factory fabrication and site installation activities.

Testing and final Entry into Service of the new system will follow the guidelines set by the PTA and Testing window will be aligned with other stakeholders and closure planning.

16.7.7 Cannington Turnback Construction

The new double ended turnback will be constructed using conventional railway construction methodologies with the construction steps as shown:

1. Demolition of the existing railway (including signal, track, communications and traction power assets) occurs all in accordance with PTA and ALUA processes.
2. Construct railway earthworks
3. Construct the MCR and UTX's from the MCR. Local cable routes are not constructed at this time.
4. Construct OLE foundations.
5. Construct plain track and turnouts. This includes the centre track, crossover and turnouts. Turnouts will be constructed in accordance with the manufacturer's drawings. Once track surfacing of the turnouts has occurred the signalling teams will mount the points motors and setup.
6. Conduct track surfacing and destressing and make ready rail for commissioning, then install buffer stops.
7. Install OLE masts and wires and register. This is conducted in coordination with surrounding OLE wiring works being mindful of wire lengths and termination locations.
8. The signalling works of installing local cable routes and signalling foundations occurs.
9. LOC cases are assembled offsite in factory conditions and made ready for delivery to site.
10. Install LOC cases, local cable routes and associated cables to trackside equipment locations.
11. When intrusive works (track surfacing / OLE works) are completed install trackside signalling equipment and make cable connections.
12. Install drivers pathways and associated supporting infrastructure.

In parallel with this, the new traction power connections are made. This includes a new HV route to accommodate a new neutral section. Once the turnback is constructed and local testing completed it will form part of the final railway system for commissioning and entry into service purposes.

Appendix A – Indicative Intersection Phasing

- Indicative plans for intersection closures. Detailed TCP's shall be completed by qualified RTM and submitted to relevant stakeholders for review and approval prior to implementation.

Mint/Archer Intersection closure

High Level Strategy:
Close intersection and divert traffic via Oats Street
Manage local traffic and pedestrians around construction activities within work area

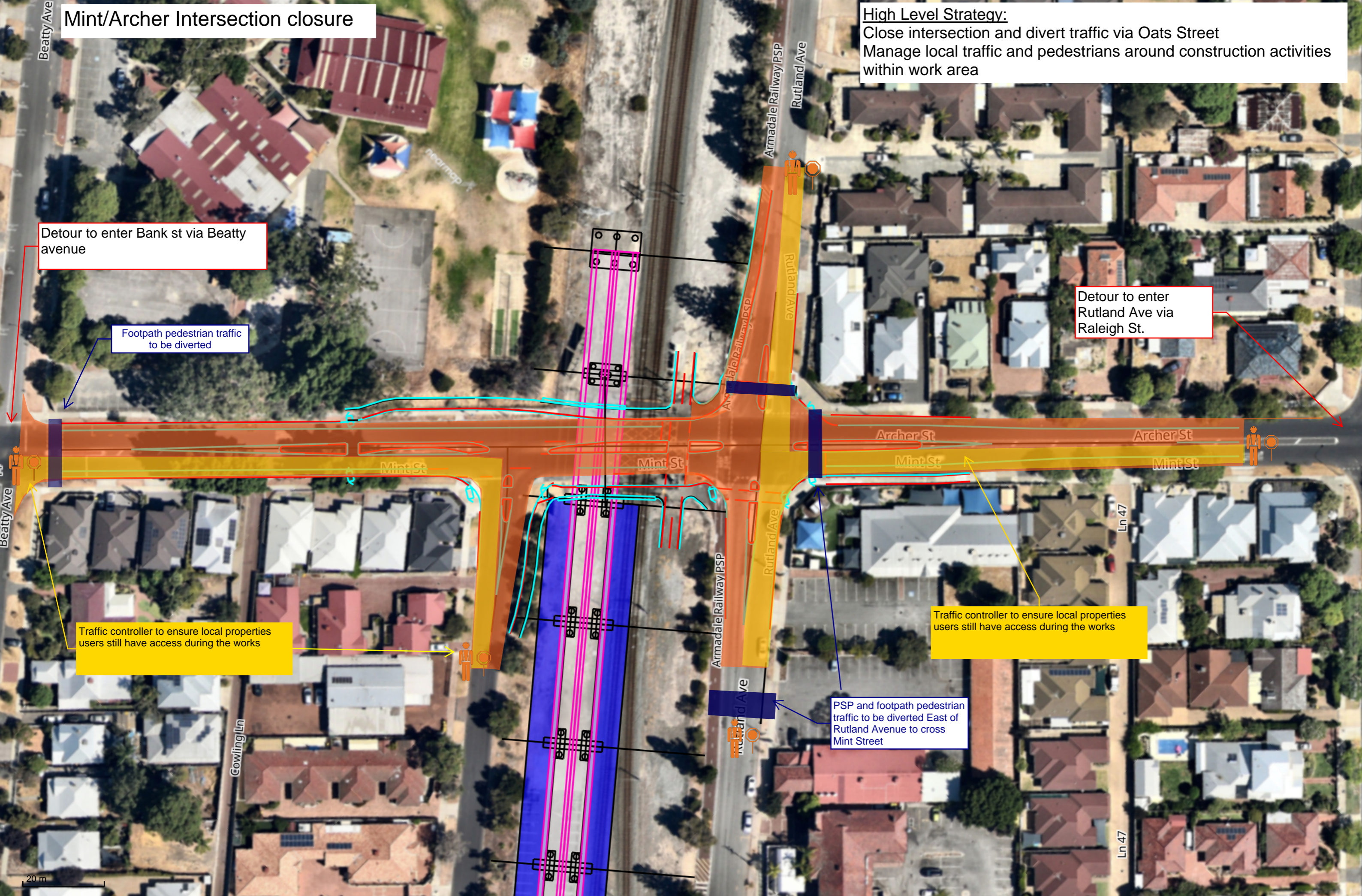

Detour to enter Bank st via Beatty avenue

Footpath pedestrian traffic to be diverted

Detour to enter Rutland Ave via Raleigh St.

Traffic controller to ensure local properties users still have access during the works

Traffic controller to ensure local properties users still have access during the works

PSP and footpath pedestrian traffic to be diverted East of Rutland Avenue to cross Mint Street

20 m

Wharf Street Level Crossing Removal

Oats Street Intersection closure

High Level Strategy:
Close intersection and divert traffic via Mint Street
Manage local traffic and pedestrians around construction activities within work area

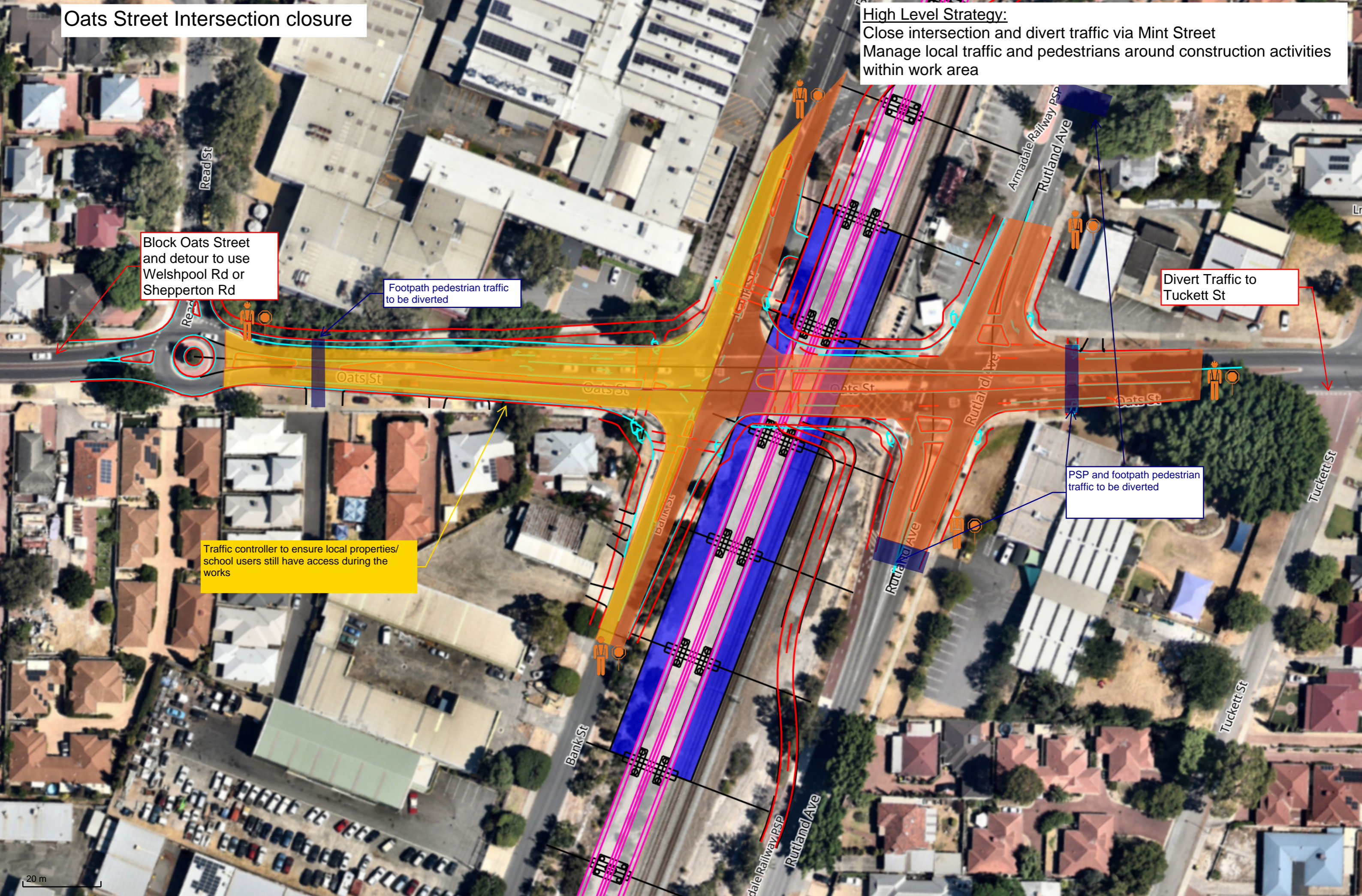

20 m

Wharf Street Level Crossing Removal

Welshpool Road Intersection Closure

High Level Strategy:
Close intersection and divert traffic via Oats Street & Hamilton
Manage local traffic and pedestrians around construction activities within work area

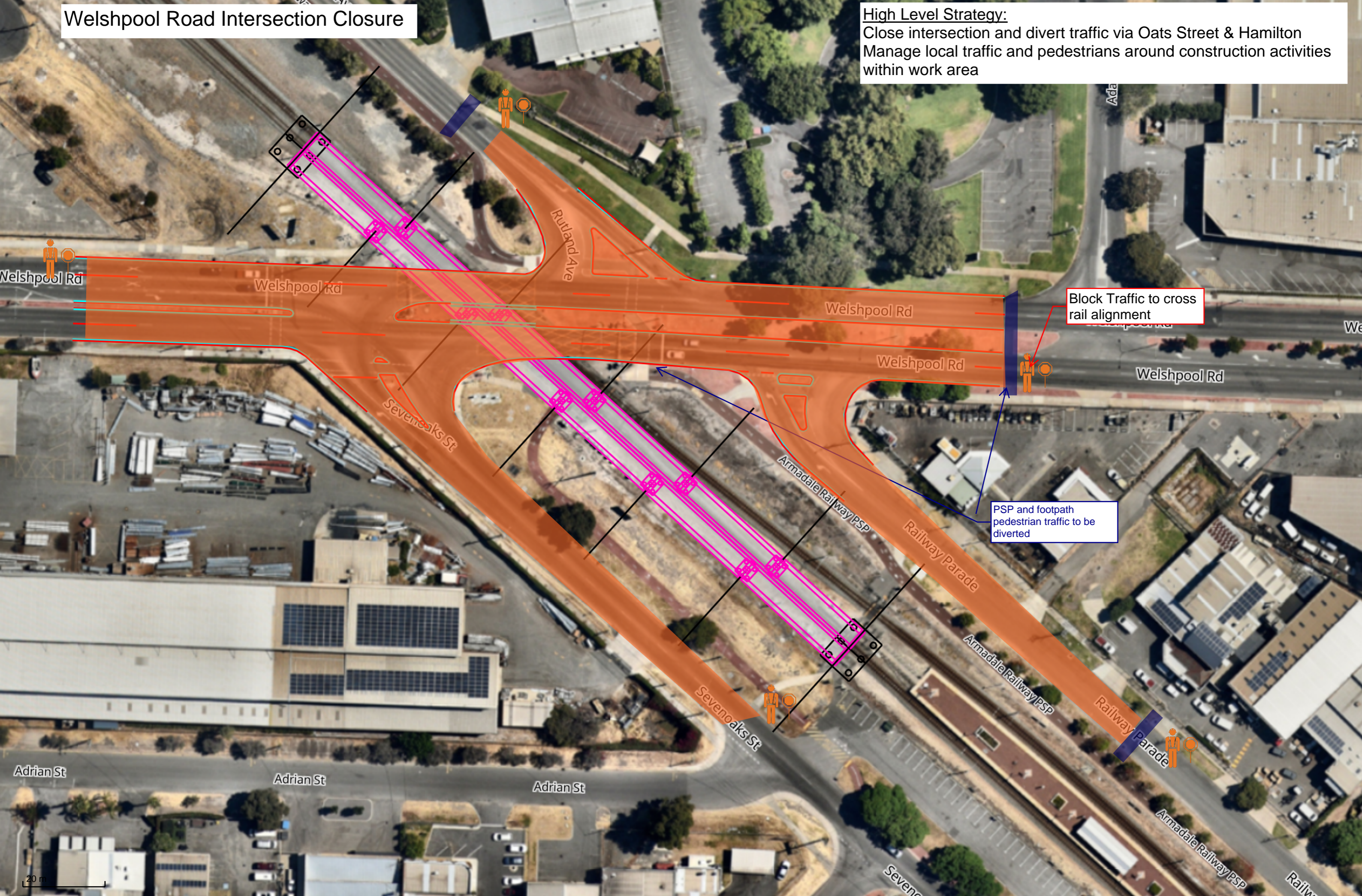

Block Traffic to cross rail alignment

PSP and footpath pedestrian traffic to be diverted

Wharf Street Level Crossing Removal

Hamilton Street Intersection Closure

High Level Strategy:
Close intersection and divert traffic via Welshpool and Wharf Street
Manage local traffic and pedestrians around construction activities within work area

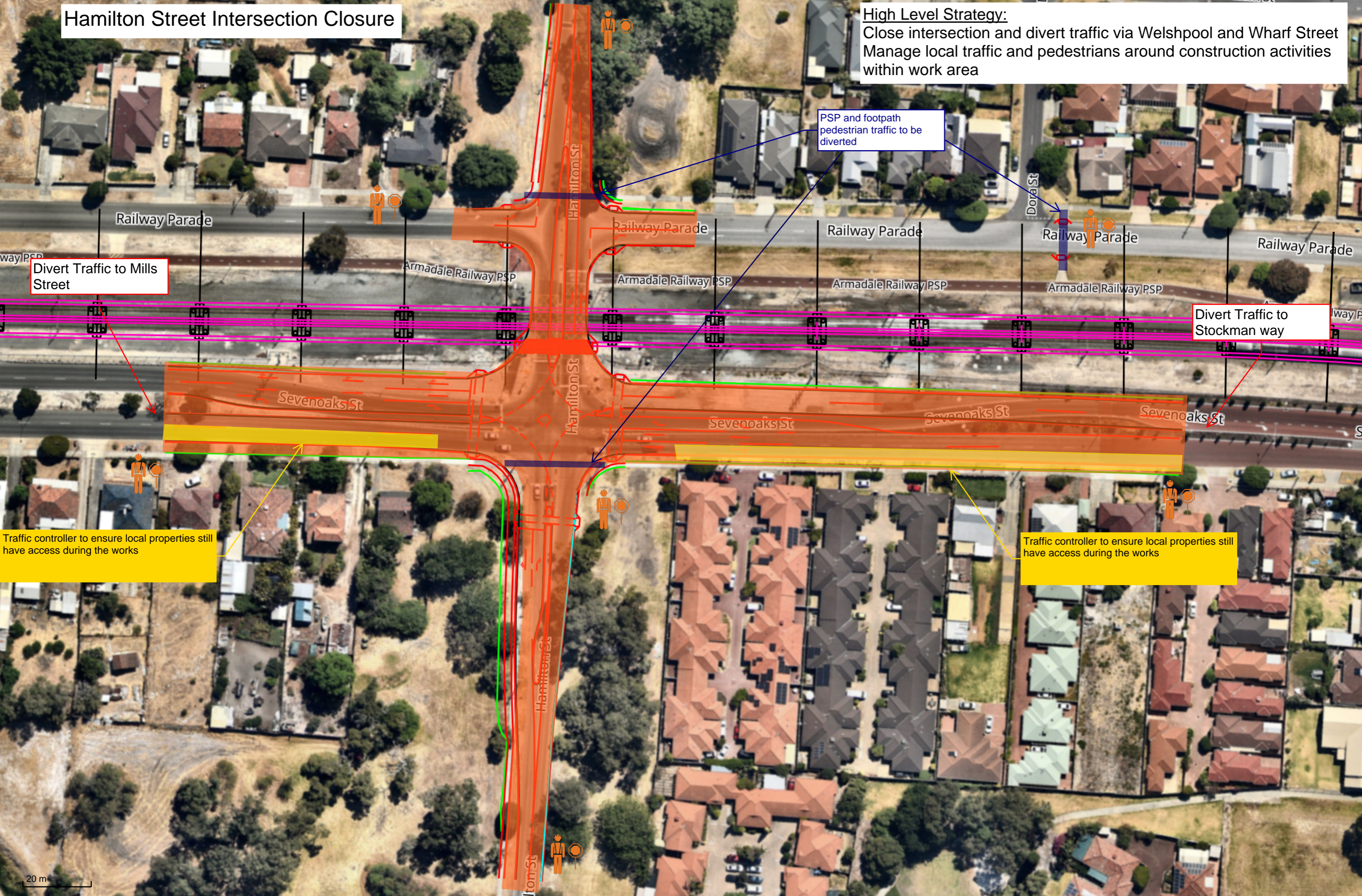

Divert Traffic to Mills Street

Divert Traffic to Stockman way

PSP and footpath pedestrian traffic to be diverted

Traffic controller to ensure local properties still have access during the works

Traffic controller to ensure local properties still have access during the works

20 m

Wharf Street Level Crossing Removal

Wharf Street Intersection Closure

High Level Strategy:
Close intersection and divert traffic via Hamilton Street
Manage local traffic and pedestrians around construction activities within work area

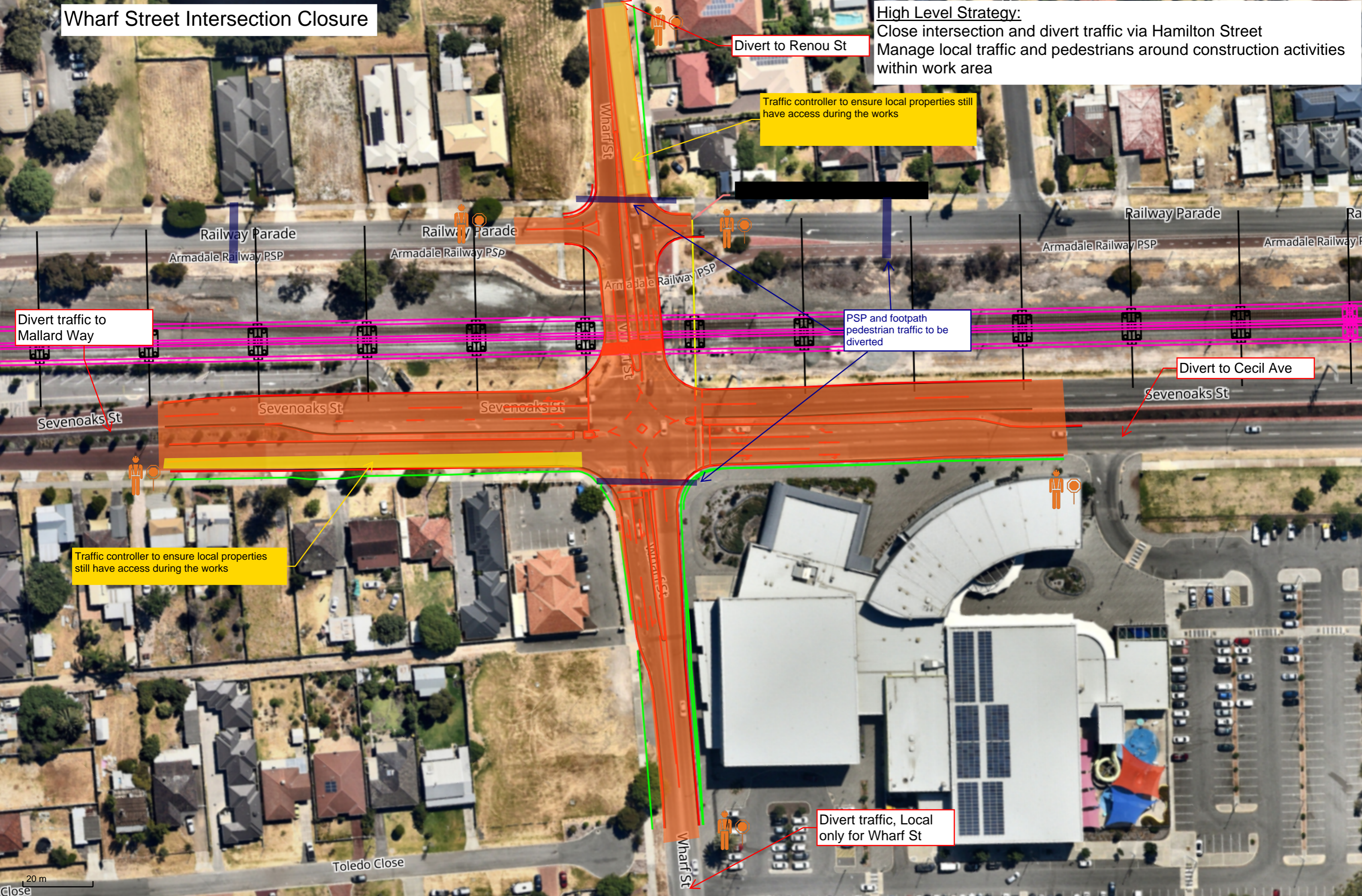

Divert to Renou St

Traffic controller to ensure local properties still have access during the works

Divert traffic to Mallard Way

PSP and footpath pedestrian traffic to be diverted

Divert to Cecil Ave

Traffic controller to ensure local properties still have access during the works

Divert traffic, Local only for Wharf St

20 m

Close

Wharf Street Level Crossing Removal

[Map link](#)

Datum / Projection: GDA94 / PCG94

Appendix B – Traffic Management Plan including Heavy Haulage Strategy

ALUA-TMP-001_ Early Works





WORKS ON ROADS TRAFFIC MANAGEMENT PLAN

ARMADALE LINE UPGRADE WORKS VICTORIA PARK STATION TO BECKENHAM STATION PROJECT EARLY WORKS REF: ALUA-TMP-001

DECLARATION:

I, Daniel Schmidt (AWTM Cert No. STAP-AWTM-20-02303-02), declare that I have designed this Traffic Management Plan following information from a site inspection on 28/03/2022. The Traffic Management Plan prepared is in accordance with the Main Roads Code of Practice and AGTTM3.

Signature:  Date: 04/04/2021

	Name / Company	Accreditation	Date	Signature
TMP designed by	Daniel Schmidt Strada Consultants	STAP-AWTM-20-02303-02	04/04/2022	
Revision by	Timo Schwarz Strada Consultants	KTS-AWTM-20-48578-02	12/09/2022	
RTM Reviewed & Endorsed by	Travis Green Strada Consultants	RTM 037	12/09/2022	
Road Authority Review by	N/A For Stage 1 works			
Road Authority Authorisation	Road authority authorisation of the implementation of traffic signs and devices is given for Traffic Management Plan No. C-SA-TMP-001			
	Signed	Authorised Officer		Date
	(Print Name)	Position		

REVISION REGISTER

Revision	Date	Revision Description	Issued By
A	04/04/2021	Issued For Stakeholder Review	Daniel Schmidt
0	15/07/2022	Added TGS for further service locating works (TGS-006) and generic PSP/path TGS (098 & 099) for works on paths >6m off road edge. Minor updates throughout the document to include relevant items for new TGSs	Timo Schwarz
1	2/08/2022	Added new TGS for additional service locating works along verges and median and car parks/bus areas of stations.	Timo Schwarz
2	12/09/2022	Added new TGS 013 to 028 for additional service locating works near Level Crossings of Mint/Archer Street and Oats Street and verges of Bank Street	Timo Schwarz

Contents

GLOSSARY	6
<hr/>	
1 INTRODUCTION	7
<hr/>	
1.1 PURPOSE AND SCOPE	7
1.2 OBJECTIVES AND STRATEGIES	7
2 PROJECT OVERVIEW	9
<hr/>	
2.1 PROJECT LOCATION	9
2.2 PROJECT DETAILS, SITE ASSESSMENT AND SITE CONSTRAINTS/IMPACTS	11
2.3 EXISTING TRAFFIC AND ROAD ENVIRONMENT	12
2.4 OVERVIEW OF PROPOSED TTM	13
2.5 PROJECT REPRESENTATIVES	15
3 RISK MANAGEMENT	16
<hr/>	
3.1 PROJECT REPRESENTATIVES	ERROR! BOOKMARK NOT DEFINED.
3.2 RISK REGISTER	20
4 TRAFFIC MANAGEMENT PLANNING AND ASSESSMENT	24
<hr/>	
4.1	24
4.1.1 TRAFFIC AND SPEED DATA	24
4.1.2 TRAFFIC FLOW ANALYSIS	24
4.1.3 TEMPORARY SPEED ZONES	24
4.1.4 EXISTING TRAFFIC SIGNALS	24
4.1.5 IMPACT TO ADJOINING NETWORK	24
4.1.6 END OF QUEUE TREATMENT	25
4.1.7 TEMPORARY TRAFFIC SIGNALS	25
4.2 ROAD USERS	25
4.3 NIGHT WORK PROVISIONS	26
4.4 ROAD SAFETY BARRIERS	27

4.5	CONSULTATION AND COMMUNICATION / NOTIFICATION	27
5	SITE ASSESSMENT	28
5.1	PROVISION TO ADDRESS ENVIRONMENTAL CONDITIONS	28
5.2	EXISTING TRAFFIC AND ADVERTISING SIGNAGE	30
6	SAFETY PLAN	31
6.1	OCCUPATIONAL SAFETY AND HEALTH	31
6.2	ROLES AND RESPONSIBILITIES	31
6.3	PERSONAL PROTECTIVE EQUIPMENT	33
6.4	PLANT AND EQUIPMENT	34
6.5	TRIP HAZARDS	34
7	IMPLEMENTATION	35
7.1	TRAFFIC GUIDANCE SCHEMES	35
7.2	SEQUENCE AND STAGING	38
7.3	TRAFFIC CONTROL DEVICES	38
7.4	SITE ACCESS FOR WORK VEHICLES	41
7.5	COMMUNICATING TMP REQUIREMENTS	42
8	EMERGENCY ARRANGEMENTS AND CONTINGENCIES	43
8.1	TRAFFIC INCIDENT PROCEDURES	43
8.2	EMERGENCY SERVICES	44
8.3	DANGEROUS GOODS	44
8.4	DAMAGE TO SERVICES	44
8.5	FAILURE OF SERVICES	44
8.6	EMERGENCY CONTACTS	45
9	MONITORING AND MEASUREMENT	46
9.1	DAILY INSPECTIONS	46
9.2	TMP AUDITS AND INSPECTIONS	48
9.3	RECORDS	48

10 MANAGEMENT REVIEW AND APPROVALS **49**

10.1 TMP REVIEW AND IMPROVEMENT 49

10.2 VARIATIONS 49

10.3 APPROVALS 49

APPENDIX A - NOTIFICATION OF ROAD WORKS **50**

APPENDIX B - VARIATION TO STANDARDS **54**

APPENDIX C - RECORD FORMS **57**

APPENDIX D - TRAFFIC ANALYSIS AND VOLUME COUNTS **62**

GLOSSARY

Term	Definition
AWTM	Advanced Worksite Traffic Management
AGTTM	Australian Guide to Temporary Traffic Management
BWTM	Basic Worksite Traffic Management
CAH	Controlled Access Highway
CAR	Corrective Action Report
CIC	Customer Information Centre
COP	Code of Practice
FWY	Freeway
HVO	Heavy Vehicle Operations
HVS	Heavy Vehicle Services
HWY	Highway
IFC	Issued For Construction
LGA	Local Government Authority
MRWA	Main Roads Western Australia
OS&H	Occupational Safety and Health
OSH MR	Occupational Safety and Health Main Roads Representative
RNOC	Road Network Operations Centre
RSA	Road Safety Audit(or)
RTM	Roadworks Traffic Manager
SCATS	Sydney Co-ordinated Adaptive Traffic System
SIDRA	Signalised and un-signalised Intersection Design and Research Aid
SWTC	Scope of Work and Technical Criteria
TGS	Traffic Guidance Scheme
TMA	Truck/Trailer Mounted Attenuator
TRD	Temporary Road Design
TTM	Temporary Traffic Management
VMS	Variable Message Sign
WTM	Worksite Traffic Management

1 INTRODUCTION

1.1 Purpose and Scope

This Traffic Management Plan (TMP) outlines the traffic control and traffic management procedures to be implemented by the ALUA Project Manager (and duly accredited personnel assigned by the Project Manager) to manage potential hazards associated with the traffic environment during the project.

The scope of works documented in this TMP addresses the early works components to support design and later construction activities.

Works will include (but not be limited to) sign installation, feature surveying, pavement testing, pot holing, geotechnical testing, service locating, and clearing. The work locations have been assessed and site specific or generic controls have been developed for works in close proximity to traffic. In order to undertake these works, traffic control devices will need to be established on the affected roads to provide advance warning to motorists.

Traffic Management will enable the Contractor to establish a safe working environment for workers, plant and equipment while undertaking the works, without conflicting with traffic on the roads. The purpose of the Traffic Management Plan is to safely guide / direct road users past the work site.

1.2 Objectives and Strategies

The objectives of the Traffic Management Plan are to ensure:

- The safety of the road workers.
- All road users, including vulnerable road users, are safely guided around, through or past the work site.
- The performance of the road network is not unduly impacted and the disruption and inconvenience to all road users are minimised for the duration of the works.
- Impacts on users of the road reserve and adjacent properties and facilities are minimised.

In an effort to meet these objectives the Traffic Management Plan will incorporate the following strategies:

- Providing a sufficient number of traffic lanes to accommodate vehicle volumes.
- Ensuring delays are minimised by only implementing lane closures in accordance with AGTTM3 and MRWA Code of Practice requirements.
- Ensuring all road users are managed including motorists, pedestrians, cyclists, people with disabilities and people using public transport.

Traffic Management Plan

- Ensuring property access is maintained and changed conditions communicated to appropriate stakeholders.
- Ensuring work activities are carried out sequentially to minimise adverse impacts.
- Provision will be made for works personnel to enter the work area in a safe manner in accordance with safety procedures.
- All entry and exit movements to and from traffic streams shall be in accordance with the requirements of safe working practices.
- Affected roads are included in HVO RAV Network 2-4. Traffic management will not impact on the movements of affected vehicle classes.

2 PROJECT OVERVIEW

2.1 Project Location

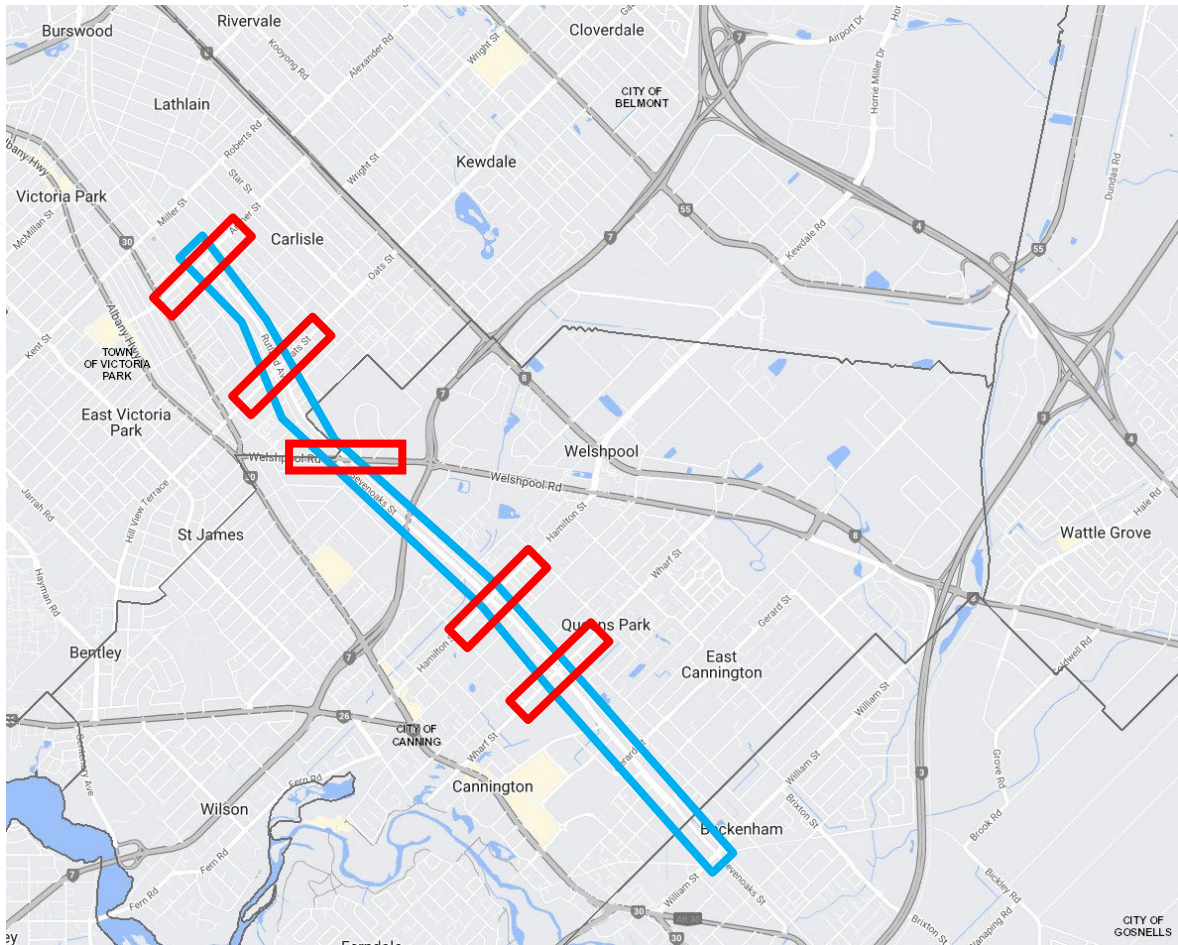

Figure 1 – Site Location

The works outlined in this TMP are highlighted in the area shown in Figure 1. The work area is primarily defined by the Armadale Line rail corridor, commencing at the Miller St grade separation in Carlisle, continuing to south to William Street in Beckenham.

General work areas are shown in BLUE, level crossing areas in RED above. The following roads are within the work area

West of Rail corridor:

- Sevenoaks Street
- Bank Street

East of Rail corridor:

- Railway Parade
- Rutland Avenue

Level Crossings:

- Mint Street
- Oats Street
- Welshpool Road
- Hamilton Street
- Wharf Street

The works fall within the LGA boundaries of:

Town of Victoria Park.

City of Canning.

City of Gosnells.

2.2 Project Details, Site Assessment and Site Constraints/Impacts

ITEM	DESCRIPTION
Project	Armadaale Line Upgrade Project
Location	<ul style="list-style-type: none"> • Armadale Rail Line, from Victoria Park Station to north of Beckenham Station. • All stations and carparks within the above section. • Adjacent Public Roads (Not impacted in phase 1 of early works – planning will be developed in a later stage and issued as a later revision of this TMP).
Road Classification, Existing Speed Limit	N/A for current works stage, all works isolated within PTA Carparks
Road Authority	PTA (parking facilities only impacted)
Local Government	N/A
Client	ALUA
Prime Contractor	ALUA
Sub-Contractor	Altus Traffic Management
Scope of Works	<p>The following early site exploration activities will occur (typically, but not limited to):</p> <ul style="list-style-type: none"> • Service locating of existing assets and services. • Complete service transfers and ensuring checks conducted so that no services are missed. • Geotechnical and Pavement Testing. • Complete asphalt, paving, kerbing and other reinstatement as necessary. • Service Locating Equipment: <ul style="list-style-type: none"> ○ Vacuum Potholing Truck or Trailer ○ CPT Rig ○ Light Vehicles (Utes) ○ Electronic Locating Equipment including GPR.
Staging of Work / Temporary Traffic Management	<p>Early Works-</p> <ul style="list-style-type: none"> • Stage 1: limited to closure of parking bays within PTA station parking facilities along the project section length. • Stage 2: Verge Works along Sevenoaks Street, Railway Parade and Bank Street, works on PSP and paths • Additional specific verge and median works on Sevenoaks Street near Cecil Avenue and Hamilton Street for service locating required or design
Project Date	
Hours / Days of Work	<p>See TGS's for site specific implementation hours or required restrictions.</p> <p>Typically 0700 hours through 1900 hours.</p> <p>Night works in the Queens Park Station car park and Oats Street bus depot/stop are carried out at night time, pending PTA and LGA</p>

ITEM	DESCRIPTION
	approvals for out of hours work. All works are off the road and restricted to parking and bus stop locations.
Duration of Work	Typically, 8-12 hours per shift Scope will evolve and will be detailed in on-going revisions of this TMP
Other Constraints	The following site constraints / impacts have been taken into consideration in the design of the traffic guidance schemes: <ul style="list-style-type: none"> • PTA parking access and parking bay management needs. • Bus facility management • School zones and crossings • PSP/shared path users • Traffic volumes at signalised intersections • Signalised intersections at level crossings
Concurrent/adjacent Works or Projects	BMD is carrying out works on Cecil Avenue. ALUA has access to a copy of the approved TMP CECIL AVENUE EAST UPGRADE WORKS - STAGES 1A AND 1B WORKS EDGE2022_PR1116 TMP_FINAL Version 1.04 26.05.2022 Necessary signs deployed for these plans are shown on the respective TGSs Works by the Leach Welshpool Alliance are carried out north of the works shown on TGS 007. Signs and locations were obtained during a site inspection on 2 nd August 2022.

2.3 Existing Traffic and Road Environment

ITEM	DESCRIPTION
Traffic Volume and Composition	No on road works in Stage 1 scope (PTA Parking facilities only) Refer to section 4.1.1 and Appendix D
Existing Road Configuration	Sevenoaks Street – various lane and carriageway configuration, single lane each way, two lanes each way, dual carriageway with one or two lanes, median separated. Signalised intersections and T-junctions as well as unsignalised T-junctions with minor local roads. School Zones and Crossings as well as pedestrian crossings. Entrances to PTA car park facilities and bus interchanges at stations. Railway Parade – single lane each way with school zones and crossings at various locations. Signalised and unsignalized intersections as well as T-junctions with minor local roads. Entrances to PTA car park facilities and bus interchanges at stations. Mint Street/Archer Street - single lane each way, school zones and crossings Oats Street – single lane each way, school zones and crossings Welshpool Road – dual lane each way, some section median divided dual carriageway Rutland Avenue – single lane each way

ITEM	DESCRIPTION
	Bank Street – single lane each way, no through road at southern end Hamilton Street – single lane each way Wharf Street – single lane each way
Existing Pedestrian / Cyclist Facilities	Shared path along Armadale line at various distances offset to the road. In Station areas, PSP/shared path turns into a “Shared Zone” as required. Typically 3m wide. Sevenoaks Street has pedestrian facilities mostly on the western verge and on the eastern verge when near rail stations. Railway Parade has access to the PSP/Shared Path that runs east of the Armadale Rail line as well as a pedestrian path on the eastern verge On road cycle facilities on Oats Street, either side of the level crossing

2.4 Overview of Proposed TTM

ITEM	DESCRIPTION
Temporary Traffic Management Descriptions	Refer to section 2.2 Project Details - ‘Staging of Work / Temporary Traffic Management.’ The traffic management outlined in this TMP will consist of advance warning signs, localised work zone closures only (STAGE 1). Works in Stage 2 include verge and median work areas that require speed reductions, lane closures and possible stop/slow operation carried out by Traffic Controllers. Localised lane/road closures are required for some service locating works. Appropriate detours will be provided.
Speed Zone dates and times	As all works for Stage 1 are located within parking facilities application of speed zones would be potentially unsafe. Stage 2 requires temporary speed zones of 40km/h where workers are within 1.2m of the road edge
Lane Closures dates and times	N/A for Stage 1 Additional areas in Stage 2 required lane closures. Times for these lane closures are based on traffic volume and will provide adequate number of lanes available.
Road Closures dates and times	Some works require localised road closures (in one or both directions). The dates will be advised by ALUA via the notification of roadworks process. The closures are of localised and short duration with minor detours and therefore do not require further advance advertising, unless noted on the relevant TGS.
Signal modifications description	N/A
Proposed lane widths	Minimum of 3.2m, where possible 3.5m
Road Safety Barrier	N/A

The temporary speed limit and length of work zone has been determined based on work requirements and compliance with AGTTM Part 3 Table 5.5 (see below).

Temporary speed limit (km/h)	Length of zone (m)	Conditions
≤ 40	100 – 200	<ul style="list-style-type: none"> high level of hazard for workers on foot.
40	100 (minimum) – 500 (maximum)	<ul style="list-style-type: none"> workers on foot within 1.2 m of traffic with no physical barrier structural danger to bridges.
60	150 (minimum)	<ul style="list-style-type: none"> workers on foot or small plant within 3 m of traffic with no physical barrier (i.e. road safety barrier) on approach to the traffic controller or PTCO reduced visibility (e.g. dust or smoke) reduced standard alignment degraded pavement surface newly laid bituminous seal.
80	500 (minimum)	<ul style="list-style-type: none"> workers on foot or plant within 3 – 6 m of traffic with no physical barrier disturbance to alignment or pavement surface.
80 (buffer)	300 (minimum)	<ul style="list-style-type: none"> for advance warning of a 40 or 60 km/h when speed is 100 km/h or more.

For any works involving excavations, the delineation and additional protection (if required) has been determined based on AGTTM Part 3 Table 6.1 (see below). For the purpose of temporary works, a non-frangible above ground hazard is treated as an excavation >500mm deep.

Speed (km/h)	Traffic volume (vpd)*	Clearance to excavation (m)	Protection required		
			Depth of excavation (mm)		
			50 to 250	251 to 500	>500
≤ 65	Any	< 2.5	Option 1	Option 2	Option 3
		2.5 - 5	Option 1	Option 1	Option 2
		> 5	Option 1	Option 1	Option 1
≥ 70	≤ 1500	≤ 5	Option 1	Option 2	Option 3
		> 5	Option 1	Option 1	Option 1
	> 1500	≤ 6	Option 1	Option 2	Option 3
		> 6	Option 1	Option 1	Option 1

* For multilane roads use volume in one direction. For two-lane, two-way roads use the sum of both directions. Any variations to the recommendations in this table need to be supported by a risk assessment.

** For Options 1 and 2, cones or bollards are to be placed at the top of the excavation.

The protection options are:

- Option 1 – Use traffic cones or bollards at standard spacing.
- Option 2 – Use traffic cones or bollards at maximum 4m spacing.
- Option 3 – Use a suitable road safety barrier system.

2.5 Project Representatives

Position	Name	Contact Details
Road Authority Representatives		
Contact		
Road Authority Representatives		
Contact		
Rail Authority Representatives		
Contact		
Prime Contractor		
Project Manager		
Site Supervisor/ Manager		
TMP Design		
TMP Implementation		
Traffic Management Supervisor		

ALUA have engaged Strada Consultants Pty Ltd to prepare this Traffic Management Plan and associated controls for the works.

3 RISK MANAGEMENT

The following details the preliminary assessment of site hazards likely to be encountered, the level of risk associated with each, and the control proposed. Note that the risk level is the level of assessed risk *without* the controls in place. The controls listed have been determined as being appropriate in reducing the risk to a level that is acceptable.

The hierarchy of control has been utilised to ensure that the highest practicable level of protection and safety is selected:

- Elimination
- Substitution
- Isolation
- Engineering
- Administration
- Personal Protection Equipment

In evaluating the options, a key consideration is whether the option takes traffic around, through or past the worksite.

3.1 Risk Classification Tables

QUALITATIVE MEASURES OF CONSEQUENCE OR IMPACT

Level	Consequence	Description
1	Insignificant	Mid-block hourly traffic flow per lane is equal to or less than the allowable lane capacity detailed in AS1742.3. No impact to the performance of the network. Affected intersection leg operates at a Level of Service (LoS) of A or B. No property damages.
2	Minor	Mid-block hourly traffic flow per lane is greater than the allowable road capacity and less than 110% of the allowable road capacity as detailed in AS1742.3. Minor impact to the performance of the network. Intersection performance operates at a Level of Service (LoS) of C. Minor property damage.
3	Moderate	Midblock hourly traffic flow per lane is equal to and greater than 110% and less than 135% of allowable road capacity as detailed in AS1742.3. Moderate impact to the performance of the network. Intersection performance operates at a Level of Service (LoS) of D. Moderate property damage.
4	Major	Midblock hourly traffic flow per lane is equal to and greater than 135% and less than 170% of allowable road capacity as detailed in AS1742.3. Major impact to the performance of the network. Intersection performance operates at a Level of Service (LoS) of E. Major property damage.
5	Catastrophic	Midblock hourly traffic flow per lane is equal to and greater than 170% of allowable road capacity as detailed in AS1742.3. Unacceptable impact to the performance of the network. Intersection performance operates at a Level of Service (LoS) of F. Total property damage.

OSH QUALITATIVE MEASURES OF CONSEQUENCE OR IMPACT

Level	Consequence	Description
1	Insignificant	No treatment required
2	Minor	First aid treatment required.
3	Moderate	Medical treatment required or Lost Time Injury
4	Major	Single fatality or major injuries or severe permanent disablement
5	Catastrophic	Multiple fatalities.

QUALITATIVE MEASURES OF LIKELIHOOD

Level	Likelihood	Description
A	Almost certain	The event or hazard: is expected to occur in most circumstances, will probably occur with a frequency in excess of 10 times per year.
B	Likely	The event or hazard: Will probably occur in most circumstances, will probably occur with a frequency of between 1 and 10 times per year.
C	Possible	The event or hazard: might occur at some time, will probably occur with a frequency of 0.1 to 1 time per year (i.e. once in 1 to 10 years).
D	Unlikely	The event or hazard: could occur at some time, will probably occur with a frequency of 0.02 to 0.1 times per year (i.e. once in 10 to 50 years).
E	Rare	The event or hazard: may occur only in exceptional circumstances, will probably occur with a frequency of less than 0.02 times per year (i.e. less than once in 50 years).

IMPORTANT NOTE: The likelihood of an event or hazard occurring shall first be assessed over the duration of the activity (i.e. “period of exposure”). For risk assessment purposes the assessed likelihood shall then be proportioned for a “period of exposure” of one year.

Example: An activity has a duration of 6 weeks (i.e. “period of exposure” = 6 weeks). The event or hazard being considered is assessed as likely to occur once every 20 times the activity occurs (i.e. likelihood or frequency = 1 event/20 times activity occurs = 0.05 times per activity). Assessed annual likelihood or frequency = 0.05 times per activity x 52 weeks/6 weeks = 0.4 times per year. Assessed likelihood = Possible.

QUALITATIVE RISK ANALYSIS MATRIX – RISK RATING

	CONSEQUENCE				
Likelihood	Insignificant (1)	Minor (2)	Moderate (3)	Major (4)	Catastrophic (5)
Almost certain (A)	Low 5	High 10	High 15	Very High 20	Very High 25
Likely (B)	Low 4	Medium 8	High 12	Very High 16	Very High 20
Possible (C)	Low 3	Low 6	Medium 9	High 12	High 15
Unlikely (D)	Low 2	Low 4	Low 6	Medium 8	High 10
Rare (E)	Low 1	Low 2	Low 3	Low 4	Medium 7

MANAGEMENT APPROACH FOR RESIDUAL RISK RATING

Residual Risk Rating	Required Treatment
Very High	Unacceptable risk. HOLD POINT . Work cannot proceed until risk has been reduced.
High	High priority, OSH MR and Roadworks Traffic Manager (RTM) must review the risk assessment and approve the treatment and endorse the TGS prior to its implementation.
Medium	Medium Risk, standard traffic control and work practices subject to review by accredited AWTM personnel prior to implementation.
Low	Managed in accordance with the approved management procedures and traffic control practices.

3.2 Risk Register

Item	RISK EVENT	CONSEQUENCE	PRE – TREATMENT RISK			TREATMENT	RESIDUAL RISK		
			L	C	RR		L	C	RR
1.	Traffic speed may create a risk of collision with other vehicles on the road, construction vehicles and construction personnel.	Potential injury to road users.	C	3	M 9	Temporary 40km/h speed zones (for works within 1.2m of live traffic) and temporary 60km/h speed zones (for works within 1.2m-3.0m of live traffic) will be applied. Work area to be separated from passing traffic with delineation and lane closures.	E	3	L 3
2.	Incorrectly designed and / or installed traffic control may result in inadequate protection of the worksite with a subsequent increased potential for crashes and injury.	Potential injury to road users.	B	3	H 12	Qualified and experienced personnel have been employed in the preparation of the TMP and associated TGS'S and experienced personnel will be used to implement and maintain the traffic control onsite.	D	3	L 6
3.	Traffic Controller may be hit by passing traffic while setting up traffic control devices	Potential injury to road users and personnel.	B	4	VH 16	Implementation shall be in line with requirements of AGTTM and setup and pack up shall follow sequences as outlined. Risk assessments (JHA/SWMS) ahead of shift start shall be documented as per Project requirements Shadow vehicles and TMAs (TL2) shall be used as required. Traffic Controllers shall work in teams to provide assistance and spotting for TCs implementing devices	D	4	M 8
4	Inclement weather may result in a decreased readability of the traffic control delineation and signage and may increase the potential for crashes.	Injury to road users.	B	3	H 12	The TMP requires that the Contractor undertakes a daily inspection of the traffic control and make adjustments as are necessary to ensure effectiveness is maintained. Experienced personnel specialising in the erection and maintenance of traffic control will be used. All signage shall be Class 1 retro-reflective.	D	3	L 6
5.	The interaction of work personnel with traffic may result in increased potential for conflict and serious injury.	Injury to work personnel.	B	4	VH 16	The TMP provides for temporary traffic controls to be installed around the work site which will reduce likelihood of conflict. Traffic Control and site containment is to be installed and maintained by appropriately qualified and experienced personnel. The TMP provides where necessary for the implementation of a closure of traffic lanes to direct traffic around the work site which will eliminate conflict.	E	4	L 4

Item	RISK EVENT	CONSEQUENCE	PRE – TREATMENT RISK			TREATMENT	RESIDUAL RISK		
			L	C	RR		L	C	RR
6.	The interaction of non-motorised road users with through traffic and work plant may result in increased potential for conflict and serious injury.	Injury to pedestrians, cyclists, and other non-motorised road users.	B	3	H 12	Pedestrian Watch Your Step signs will be erected at locations where works are being completed in close vicinity to footpaths. Traffic Controllers may provide assistance where necessary around the works.	D	3	L 6
7.	A road user may misread the required alignment vehicles are to reaction take on account of modification required to accommodate road works. This could result in through vehicles colliding with work personnel or work vehicles. The restrictions placed on the road environment by the works result in property access restrictions to local residents, property owners and tenants	Injury to road users and work personnel. Adverse public	CB	43	H 12H 12	Traffic planning requires traffic controls to be installed to direct traffic around the work site and a reduction in the speed zone of the carriageways approaching and passing the works. The TMP and TGS's detail the temporary controls and advance warning and directional signage to be used in accordance with the requirements of AGTMM3. Local access to be maintained to properties on all affected roads. Traffic control personnel to provide assistance to local drivers when accessing driveways. Local residents, property owners and tenants to be notified of the temporary restrictions if these become necessary and communicated with directly if the works will obstruct direct access to properties, driveways or parking areas.	ED	43	L 4L 6
8.	Workers exiting vehicles on the side of the live traffic lane at high speeds leads to the vehicle door or vehicle occupant being struck by a passing motorist. Restrictions and delays associated with the traffic control may cause unacceptable delays to emergency services.	Injury to road users and work personnel. Delay may result in failure to respond to emergency in time resulting in a fatality.	BC	33	H 12M 9	Workers are to exit vehicles from the side of the vehicle away from the live traffic lane unless they are further than 1.2m from the live traffic lane in a temporary 60km/h zone. The TMP details the consultation and communication mechanisms undertaken with Emergency services and how these will be managed. It also requires that all works personnel respond to emergency traffic to facilitate safe and unhindered passage where possible.	DE	33	L 6L 3
9.	The restrictions placed on the traffic lanes by the works could result in roadway capacity being decreased to the point where unacceptable delays and congestion occur.	Unacceptable delays. Adverse public reaction.	D	3	L 6	Traffic volumes analysed to determine permitted working times, ensuring that capacity is not exceeded. Low traffic volumes at all locations will permit single lane operation to comfortably take place at times prescribed on individual TGS's. On site monitoring of traffic flows will occur.	E	3	L 3

Item	RISK EVENT	CONSEQUENCE	PRE – TREATMENT RISK			TREATMENT	RESIDUAL RISK		
			L	C	RR		L	C	RR
10.	A road user may misread the required alignment vehicles are to take on account of modifications required to accommodate road works. This could result in through vehicles colliding with work personnel or work vehicles.	Injury to road users and work personnel.	C	4	H 12	Traffic planning requires traffic controls to be installed to direct traffic around the work site and a reduction in the speed zone of the carriageways approaching and passing the works. The TMP and TGS's detail the temporary controls and advance warning and directional signage to be used in accordance with the requirements of AGTTM3.	E	4	L 4
11.	Workers exiting vehicles on the side of the live traffic lane at high speeds leads to the vehicle door or vehicle occupant being struck by a passing motorist.	Injury to road users and work personnel.	B	3	H 12	Workers are to exit vehicles from the side of the vehicle away from the live traffic lane unless they are further than 1.2m from the live traffic lane in a temporary 60km/h zone.	D	3	L 6
12.	Excavations near paths (pedestrians/cyclists)	Injury to path user	B	4	VH 16	Pedestrian containment fencing shall be installed around all open excavations to prevent access from active path facilities. Sections of the PSP affected by the works are closed temporarily (long term) to eliminate conflict	E	4	L 4
13.	The interaction of path users (pedestrians, cyclists, etc.) with workers and plant while works are carried out on or near the path may lead to injuries	Injury to path user	B	3	H 12	Appropriate advance warning signs are to be displayed while works on/near the PSP/path are carried out. Workers and plant shall be always off the path. If that is not possible, appropriate delineation with at least 1.5m unobstructed path width or assistance by Traffic Controllers including stop/slow setups shall be utilised. Where setups have to be left unattended in aftercare, paths shall be reinstated to original conditions or appropriate advance warning signs shall be displayed to warn path users of uneven ground conditions.	E	3	L 3
14.	Congestion occurs as a result of the single lane operation	Significant congestion and damage to ALUA, PTA and LGA	C	3	M 9	Traffic Controllers shall observe lane closures and queuing. Where delays occur as part of the lane closure activities, the lane closures shall be removed to resolve any congestion.	D	3	L 6

Traffic Management Plan

Item	RISK EVENT	CONSEQUENCE	PRE – TREATMENT RISK			TREATMENT	RESIDUAL RISK		
			L	C	RR		L	C	RR
15.	Property driveways present within the work zone are blocked by Traffic Management devices prevent access and egress to properties.	Adverse public reaction	C	3	M 9	Traffic Controllers on site are to assist motorists wishing to access or egress driveways as necessary. Where signs are blocking line of sight in and out of driveways, Traffic Controllers shall adjust sign spacing in line with AGTTM requirements	D	3	L 6
16	Uncontrolled shuttle flow operation may lead to collisions	Injury to road users and property damage	B 12	3	H	Uncontrolled shuttle flow operation is restricted to 60m in total length and shall only be deployed when visibility is not impacted (vegetation or parked vehicles). Setup is restricted to areas indicated on TGS and shall not be used near intersections or where parked vehicles (on verge) prohibit traffic to pass.	D	3	L 6
17	Closure of left turn lane in combination with provision to turn left from right lane puts cyclists in conflict with other road users (TGS 020).	Injury to road users	B 12	3	H	Cycle lane near closed left turn pocket shall remain accessible. Additional warning signs for cyclists in lane are installed ahead of intersection	D	3	L 6

4 TRAFFIC MANAGEMENT PLANNING AND ASSESSMENT

4.1 Traffic Assessment and Analysis

4.1.1 Traffic and Speed Data

Refer to Appendix D for traffic volumes and other data.

4.1.2 Traffic Flow Analysis

Traffic flow will be maintained by means of the prescribed traffic control arrangements outlined in this TMP. Traffic volumes and movements will be analysed against the requirements detailed in the AGTTM3 and MRWA risk tables (see section 6) to ensure levels of service are acceptable to the Road Authority, so that lane closures when utilising single lane operation can be implemented at times when the affected roads do not exceed capacity.

Average Daily Totals on the affected roads, summarized in Appendix D of this TMP, indicate that no congestion will be experienced during the proposed hours of the works.

Where Roads are closed as part of the works in the vicinity of PTA stations, the closures are outside peak hour times to avoid unnecessary impact on commuters.

4.1.3 Temporary Speed Zones

Temporary speed zones 40km/h will be implemented on roads where workers are likely to be within 1.2m from road edge as required by the works. Existing traffic speed zones will be reinstated at the end of each work shift.

4.1.4 Existing Traffic Signals

Various traffic signals are present along Sevenoaks Street and may be impacted by the early works. These impacts are mostly limited to lane closures through, ahead or after traffic signals. Approval from MRWA RNOC shall be obtained 10 business days ahead of such works. The relevant LM number will be noted on the TGS.

The signals along Sevenoaks Street that may be impacted are:

- LM 0934 Welshpool Road
- LM 0640 Hamilton Street
- LM 0682 Wharf Steet
- LM 0542 Cecil Avenue

All these signals are also linked to the respective level crossing at the location. It is the intent to not impact on the signal phasing as such that level crossing performance or safety is impacted. In this TMP the impacts will be reduced to the north south movements along Sevenoaks Street and implementation times will be selected to be outside peak hours in the morning and afternoon to minimise any impact on the performance of the signals.

4.1.5 Impact to Adjoining Network

No impact on the surrounding network is expected.

4.1.6 End of Queue Treatment

N/A

4.1.7 Temporary Traffic Signals

N/A

4.2 Road Users

4.2.1 Pedestrians

See section 2.3 for pedestrian facility locations near the proposed work sites.

Pedestrian Watch Your Step signs will be erected at locations where works are being completed in close vicinity to footpaths.

When required, traffic controllers will be present to monitor pedestrian movements and render assistance around or through the work site as required.

Where works are undertaken on or near the PSP/path appropriate advance warning signs shall be displayed. Traffic Controllers may be required to stop path users while works progress and pose a risk for path users. Where required, aftercare signs shall warn PSP/path users of potential trip hazards or uneven surface that cannot be removed/reinstated at the end of the shift. All excavations shall be barricaded off to prevent unintended access by PSP/path users.

4.2.2 Cyclists

Where works are undertaken on or near the PSP/path appropriate advance warning signs shall be displayed. Traffic Controllers may be required to stop path users while works progress and pose a risk for path users. Where required, aftercare signs shall warn PSP/path users of potential trip hazards or uneven surface that cannot be removed/reinstated at the end of the shift. All excavations shall be barricaded off to prevent unintended access by PSP/path users.

In cases where surface conditions are such that cyclists cannot traverse the work area safely, as a last resort the cyclists dismount sign shall be displayed for short durations only.

4.2.3 Public Transport

Works in Stage 1 impacting PTA services are limited to PTA parking facilities: As such PTA approval of the closure of parking bays to undertake works will be required.

Sevenoaks Street has, multiple bus routes operating along it. Works do not impact these routes or bus stops.

Works on Oats Street require the temporary closure of Bank Street (southbound direction only). The closure will still provide access for busses along Bank Street. Traffic Controllers will assist busses leaving Oats Street Station. PTA shall be notified ahead of the works to notify bus operators accordingly about these works.

4.2.4 Heavy and Oversized Vehicles

Traffic Management Plan

4.2.5 Existing Parking Facilities

Stage 1 project early works are limited to PTA parking facilities: As such PTA approval of the closure of parking bays to undertake works will be required.

ALUA team to liaise with PTA to determine notification requirements and approvals.

Parking facilities along the road may be impacted by works or signs being placed along the road. These impacts are minimal.

4.2.6 Access to Adjoining Properties / Business

Access to adjoining properties and businesses shall be maintained at all times and Traffic Controllers shall ensure that signs do not block line of sight in and out of driveways to properties.

4.2.7 Rail Crossings

Works for Stage 1 will not occur in the vicinity of rail crossings.

Works for service locating may occur in the vicinity of rail crossings. Where works extend through signals linked to rail crossings, only the north south leg of Sevenoaks Street will have lane closures in place to not impact on the service of the level crossing itself.

In general, no works shall impact on performance of rail crossings and no stop/slow operation is carried out in the vicinity of rail crossings (with exception of PSPs), inclusive of uncontrolled shuttle operation.

4.2.8 School Crossings

School crossings are present on Mint Street, along Sevenoaks Street. The controls used for the early works do not impact on the performance of these. Additional locations with school crossings will be added as revision necessitate.

4.2.9 Special Events and Other Works

N/A

4.2.10 Emergency Vehicle Access

The proposed works will be clearly signed. Emergency Vehicles will be given priority access at all times to the extent possible.

4.3 Night Work Provisions

The works in the PTA Queens Park Station car park and bus depot at Oats Street Station are carried out during night time to allow works to not interfere with normal station operation. The works are off the roadway. All signs used shall comply with necessary night time provisions. Where existing lighting in the car park and the bus stop/depot is insufficient, additional work lights shall be provided. TCs assisting pedestrians shall be equipped for night time work (high vis retro-reflective and wands)

4.4 Road Safety Barriers

N/A

4.5 Consultation and Communication / Notification

4.5.1 Other Agencies

N/A

4.5.2 Public

PTA to be consulted to determine public notification requirements for works within parking facilities.

Service locating works impacts are minor and require no further notification.

Road closures are one directional closures only with minor detours and require no further notification.

5 SITE ASSESSMENT

5.1 Provision to Address Environmental Conditions

5.1.1 Adverse Weather

Weather is not expected to adversely impact on the effectiveness of the traffic control detailed on the TGS's. Notwithstanding this, should adverse weather conditions be encountered during the works, the following contingency plans should be activated. Note: any adjustments to the plan shall be risk assessed and approved by someone holding a WTM or AWTM accreditation.

5.1.1.1 Rain

In the event of rain, an on-site assessment shall be made and sign spacing and tapers may be extended by 25% to account for increased stopping distances. "Slippery When Wet" signs may be placed as required and all changes shall be recorded in the daily diary.

If rain occurs, Traffic Management Personnel shall inspect the site and where signage and / or devices are not clearly visible, signage may need to be adjusted to improve visibility or if necessary, provide additional signage and delineation. Where stopping distances are adversely affected by wet surfaces, spacing between signs may need to be adjusted to provide increased reaction time for drivers. In cases where it is determined that the rain is deemed too heavy that the risk is considered unacceptable, all work shall cease until rain has cleared. All changes shall be noted in the daily diary.

5.1.1.2 Floods

Should works be affected by flooding to the extent that the worksite becomes impassable or risk is considered unacceptable, all work shall cease immediately and Traffic Controllers (or other personnel if necessary) shall be deployed immediately to close the site and direct traffic around the flooded area (under the direction of the project manager or traffic manager). Emergency services and the Road Authority shall be notified immediately and Traffic Controllers shall remain onsite until emergency services and the Road Authority personnel arrive and take control of the site.

5.1.1.3 Other adverse weather (strong winds, thunderstorms, etc.)

Prior to the commencement of works, the traffic supervisor is to check daily weather forecast and monitor for severe weather conditions. So as not to expose traffic controllers or road users to unnecessary hazardous conditions, if severe weather is forecast the project team shall consider postponing the installation of traffic management. If the decision is made to proceed with works during a window of clear weather preceding a severe weather front, the project team is to monitor the weather forecast and make every attempt to ensure that traffic management can be safely packed up before being impacted.

In the event that short term traffic arrangements are in place during an adverse weather event:

- Weighted devices will be installed on signs
- Traffic cones will be double stacked

To reduce the impact of adverse weather events on long term traffic arrangements:

- Signs may be post mounted where practicable
- Delineation may be fixed to the road surface (e.g. bolt down bollards) where practicable

In the event that the above controls are deemed to be insufficient and the maintenance and readability of devices is significantly compromised, the arrangement will be assessed and removed where/when safe to do so.

5.1.2 Sun Glare

Where sun glare is identified as adversely affecting a driver's ability to sight signage and / or traffic control devices, sign locations may need to be adjusted and additional delineation and/or traffic control devices provided to address the risk from glare. Additionally in the event that traffic control is adversely affected by glare at sunset and sunrise, traffic controllers may need to assist in maintaining low traffic speeds.

Any changes required are to be noted in the daily diary.

5.1.3 Fog/Dust/Smoke

Where fog, dust or smoke is identified as adversely affecting a driver's ability to sight signage and / or traffic control devices, sign locations may need to be adjusted and additional delineation and/or traffic control devices provided to address the risk. All changes are to be noted in the daily diary.

Should works be affected by fog, dust or smoke to the extent that risk is considered unacceptable, all work shall cease immediately and Traffic Controllers (and other personnel if necessary) shall be deployed immediately to close the site. Emergency services and the Road Authority shall be notified immediately and Traffic Controllers shall remain onsite until emergency services and the Road Authority personnel arrive and take control of the site.

5.1.4 Road Geometry, Terrain, Vegetation and Structures

Prior to the commencement of works, the supervisor shall ensure sight distance to the work area is adequate and adheres to the requirements set out in the TMP. Road geometry and terrain, including crests, have been taken into account in the design and layout of all traffic guidance schemes, allowing for adequate site distance and stopping times.

Verge trees are present at most locations. Where applicable traffic controllers are to place signage in locations that are clearly visible and easy to see. Where necessary, distance between signs can be extended by 25% to allow a clear line of sight. Signs shall be erected on both sides of the roadway (where possible) to ensure that the control measures are noticed. Locations where this is not possible are detailed on the site specific TGS's.

There are no structures preventing line of sight to traffic control signs and devices.

5.2 Existing Traffic and Advertising Signage

Temporary traffic signage from works by others shall be maintained. In case signs can be removed (noted on the respective TGS), signs shall be reinstated once works conclude.

6 SAFETY PLAN

6.1 Occupational Safety and Health

All persons and organisations undertaking these works or using the roadwork site have a duty of care under statute and common law to themselves, their employees and all site users, lawfully using the site, to take all reasonable measures to prevent accident or injury.

This TMP forms part of the overall project Safety Management Plan and provides details on how all road users considered likely to pass through, past, or around the worksite will be safely and efficiently managed for the full duration of the site occupancy and works.

6.2 Roles and Responsibilities

6.2.1 Responsibilities

The Project Manager has the ultimate responsibility to ensure the TMP is implemented for the prevention of injury and property damage to employees, contractors, sub-contractors, road users and all members of the public.

The Project Manager will ensure all site personnel are fully aware of their responsibilities, and that traffic controllers are appropriately trained and accredited and that sufficient controllers are available to ensure appropriate breaks are taken.

All personnel engaged in the field activities will follow the correct work practices as required by the CoP, AGTTM and AS1742.3.

All personnel will not commence or continue work until all signs, devices and barricades are in place and operational in accordance with the requirements of the TMP.

All personnel responsible for traffic control shall ensure that the number, type and location of signs, devices and barricades are to a standard not less than Appendix F of this plan, CoP, AGTTM and AS1742.3. Should a situation arise that is not covered by this TMP, CoP, AGTTM or AS1742.3, the Road Authority Representative shall be notified.

The Road Authority Representative may direct erection, relocation or removal of signs or devices, which, in the opinion of the Road Authority Representative, are not in accordance with the TMP and do not provide sufficient safety for road users. If such directions are not complied with, the Road Authority Representative may arrange for erection, relocation or removal by others at the cost of the Contractor.

6.2.2 Roles

The following diagram outlines the responsibility hierarchy of this contract.

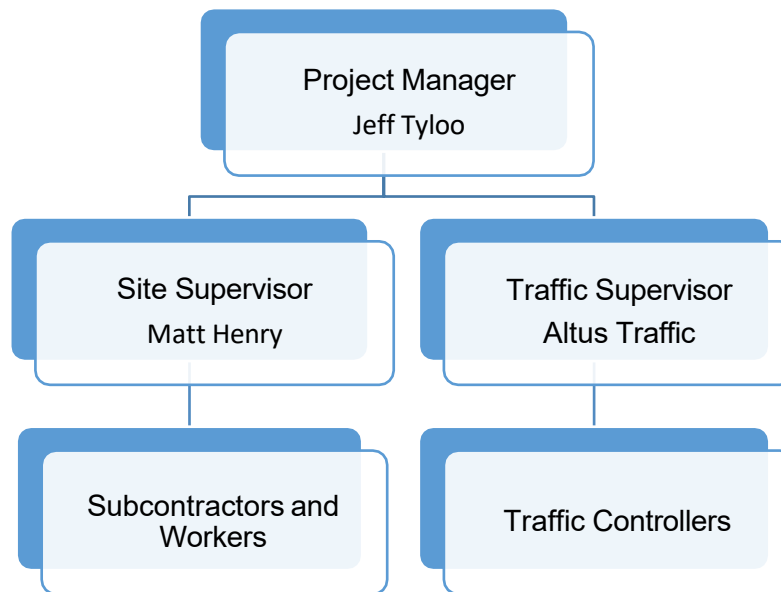

6.2.2.1 Project Manager

The Project Manager shall:

- Ensure all traffic control measures of this TMP are placed and maintained in accordance with this plan and the relevant Acts, Codes, Standards and Guidelines
- Ensure suitable communication and consultation with the affected stakeholders is maintained at all times.
- Ensure inspections of the Traffic Controls are undertaken in accordance with the TMP, and results recorded. Any variations shall be detailed together with reasons.
- Review feedback from field inspections, worksite personnel and members of the public, and take action to amend the traffic control measures as appropriate following approval from the Road Authority's Representative.
- Arrange and/or undertake any necessary audits and incident investigations.

6.2.2.2 Site Supervisor

The Site Supervisor is responsible for overseeing the day-to-day activities, and is therefore responsible for the practical application of the TMP, and shall:

- Instruct workers on the relevant safety standards, including the correct wearing of high visibility safety vests.
- Ensure traffic control measures are implemented and maintained in accordance with the TMP.
- Undertake and submit the required inspection and evaluation reports to management.

- Render assistance to road users and stakeholders when incidences arising out of the works affect the network performance or the safety of road users and workers.
- Take appropriate action to correct unsafe conditions, including any necessary modifications to the TMP.

6.2.2.3 Traffic Management Personnel

- At least one person on site shall be accredited in Basic Worksite Traffic Management and shall have the responsibility of ensuring the traffic management devices are set out in accordance with the TMP.
- At least one person accredited in Advanced Worksite Traffic Management (Strada Consultants Pty Ltd) shall be available to attend the site at short notice (or be available by phone on short notice at all times) to manage variations, contingencies and emergencies, and to take overall responsibility for traffic management.

6.2.2.4 Traffic Controllers

Traffic Controllers shall be used to control road users to avoid conflict with plant, workers, traffic and pedestrians, and to stop and direct traffic in emergency situations.

Traffic Controllers shall:

- Operate in accordance with AGTTM Part 7: Traffic Controllers
- Be accredited in Basic Worksite Traffic Management
- Hold a current Traffic Controller's accreditation
- Be relieved from their duty after not more than 2 hours for a period of rest or "other duties" of at least 15 minutes as required by AGTTM and/or OS&H Regulations.

6.2.2.5 Workers and Subcontractors

Workers and Subcontractors shall

- Correctly wear high visibility vests, in addition to other protective equipment required (e.g. footwear, eye protection, helmet sun protection etc.), at all times whilst on the worksite
- Comply with the requirements of the TMP and ensure no activity is undertaken that will endanger the safety of other workers or the general public.
- Enter and leave the site by approved routes and in accordance with safe work practices.

6.3 Personal Protective Equipment

All personnel entering the work site shall correctly wear high visibility vests to AS/NZS 4602, in addition to other protective equipment required on a site-by-site basis (e.g. protective footwear, eye protection, helmet, sun protection, respiratory devices etc.) at all times whilst on the worksite.

6.4 Plant and Equipment

All plant and equipment at the workplace shall meet statutory requirements and have the required registration, licenses or certification where required. All mobile equipment shall be fitted with suitable reversing alarms. All mobile plant and vehicles shall be fitted with a pair of rotating flashing amber lamps in accordance with AS1742.3 clause 4.14.1. All workers will be made aware of the safe work practice at the time of the site induction.

6.5 Trip Hazards

The worksite and its immediate surroundings shall be suitably protected and free of hazards, which could result in tripping by non-motorised road users. Hazards, which cannot be removed, shall be suitably protected to prevent injury to road users, including those with sight impairment. Where level differences are significant, suitable barriers, which preclude pedestrian access shall be used.

Where works extend beyond daylight hours and adjacent lighting is insufficient to illuminate hazards to non-motorised road users, appropriate temporary lighting shall be installed.

The worksite shall be kept tidy to reduce the risk to workers. Where pedestrians are required to pass through the works, Pedestrians Watch Your Step signs will be installed on each approach and Traffic Controllers will be present to assist where necessary.

7 IMPLEMENTATION

7.1 Traffic Guidance Schemes

The Traffic Guidance Schemes (TGS's) outlined in Appendix F and listed below have been provided for the following stages to demonstrate the type of controls that will be implemented throughout the term of the contract. All sign and device requirements are shown on each TGS. Should the use of additional (not shown on the TGS or listing of devices) or reduced number of devices be required due to unforeseen needs, they shall be recorded within the Daily Diary as a variation to the TMP, following prior approval.

Early Works Activities	TGS Number	Rev	Details
	ALUA-TGS-01-001	A	Typical PTA Station car park works – Carlisle Station
	ALUA- TGS -01-002	A	Typical PTA Station car park works –Oats Street Station
	ALUA- TGS -01-003	A	Typical PTA Station car park works – Welshpool Station
	ALUA- TGS -01-004	A	Typical PTA Station car park works – Queens Park Station
	ALUA- TGS -01-005		Typical PTA Station car park works – Cannington Station
	ALUA- TGS -01-006	0	ARMADALE LINE UPGRADE ALLIANCE - EARLY WORKS SERVICE LOCATING - VERGE WORKS SEVENOAKS ST NEAR QUEENS PARK STATION SPEED REDUCTION TO 40km/h
	ALUA- TGS -01-007	0	ARMADALE LINE UPGRADE ALLIANCE - EARLY WORKS SERVICE LOCATING - MP GAS LINE SEVENOAKS STREET LANE CLOSURE AND SPEED REDUCTION TO 40km/h
	ALUA- TGS -01-008	0	ARMADALE LINE UPGRADE ALLIANCE - EARLY WORKS SERVICE LOCATING - CANNINGTON TRUNK MAIN SEVENOAKS STREET - CECIL AVE DOUBLE LANE CLOSURES AND SPEED REDUCTION TO 40km/h SHEET 1 FO 2
	ALUA- TGS -01-009	0	ARMADALE LINE UPGRADE ALLIANCE - EARLY WORKS SERVICE LOCATING - CANNINGTON TRUNK MAIN SEVENOAKS STREET - CECIL AVE DOUBLE LANE CLOSURES AND SPEED REDUCTION TO 40km/h SHEET 2 OF 2
	ALUA- TGS -01-010	0	ARMADALE LINE UPGRADE ALLIANCE - EARLY WORKS SERVICE LOCATING - CANNINGTON TRUNK MAIN SEVENOAKS STREET - CECIL AVE SINGLE LANE

Early Works Activities	TGS Number	Rev	Details
			CLOSURE (SB) & SPEED REDUCTION TO 40km/h
	ALUA- TGS -01-011	0	ARMADALE LINE UPGRADE ALLIANCE - EARLY WORKS SERVICE LOCATING - QUEENS PARK STATION CAR PARK CLOSURE
	ALUA- TGS -01-012	0	ARMADALE LINE UPGRADE ALLIANCE - EARLY WORKS SERVICE LOCATING - OATS STREET STATION BUS PORT CLOSURE
	ALUA-TGS-01-013	0	ARMADALE LINE UPGRADE ALLIANCE - EARLY WORKS SERVICE LOCATING - BANK STREET BETWEEN OATS ST AND WELSHPOOL RD - SPEED REDUCTION TO 40KM/H AND OPTIONAL CONTROLLED SHUTTLE FLOW
	ALUA-TGS-01-014	0	ARMADALE LINE UPGRADE ALLIANCE - EARLY WORKS SERVICE LOCATING - BANK STREET BETWEEN OATS ST AND WELSHPOOL RD - SPEED REDUCTION TO 40KM/H AND OPTIONAL SHUTTLE FLOW
	ALUA-TGS-01-015	0	ARMADALE LINE UPGRADE ALLIANCE - EARLY WORKS SERVICE LOCATING - BANK STREET BETWEEN OATS ST AND WELSHPOOL RD - SPEED REDUCTION TO 40KM/H
	ALUA-TGS-01-016	0	ARMADALE LINE UPGRADE ALLIANCE - EARLY WORKS SERVICE LOCATING WORKS MEDIAN WORKS MINT ST & ARCHER ST
	ALUA-TGS-01-017	0	ARMADALE LINE UPGRADE ALLIANCE - EARLY WORKS SERVICE LOCATING WORKS VERGE WORKS & ROAD CLOSURE MINT ST & ARCHER ST
	ALUA-TGS-01-018	0	ARMADALE LINE UPGRADE ALLIANCE - EARLY WORKS SERVICE LOCATING WORKS VERGE WORKS & ROAD CLOSURE MINT ST & ARCHER ST
	ALUA-TGS-01-019	0	ARMADALE LINE UPGRADE ALLIANCE - EARLY WORKS SERVICE LOCATING WORKS VERGE WORKS & ROAD CLOSURE MINT ST & ARCHER ST
	ALUA-TGS-01-020	0	ARMADALE LINE UPGRADE ALLIANCE - EARLY WORKS SERVICE LOCATING WORKS VERGE WORKS & ROAD CLOSURE OATS ST & BANK ST
	ALUA-TGS-01-021	0	ARMADALE LINE UPGRADE ALLIANCE - EARLY WORKS SERVICE LOCATING WORKS VERGE WORKS & ROAD CLOSURE OATS ST & BANK ST

Early Works Activities	TGS Number	Rev	Details
	ALUA-TGS-01-022	0	ARMADALE LINE UPGRADE ALLIANCE - EARLY WORKS SERVICE LOCATING WORKS VERGE WORKS & ROAD CLOSURE OATS ST & BANK ST
	ALUA-TGS-01-023	0	ARMADALE LINE UPGRADE ALLIANCE - EARLY WORKS SERVICE LOCATING WORKS VERGE WORKS & PSP WORKS OATS ST & BANK ST
	ALUA-TGS-01-024	0	ARMADALE LINE UPGRADE ALLIANCE - EARLY WORKS SERVICE LOCATING WORKS MEDIAN WORKS AND ROAD CLOSURE OATS ST & RAILWAY PARADE
	ALUA-TGS-01-025	0	ARMADALE LINE UPGRADE ALLIANCE - EARLY WORKS SERVICE LOCATING WORKS MEDIAN WORKS AND ROAD CLOSURE OATS ST & RAILWAY PARADE
	ALUA-TGS-01-026	0	ARMADALE LINE UPGRADE ALLIANCE - EARLY WORKS SERVICE LOCATING WORKS MEDIAN WORKS AND ROAD CLOSURE OATS ST & RAILWAY PARADE
	ALUA-TGS-01-027	0	ARMADALE LINE UPGRADE ALLIANCE - EARLY WORKS SERVICE LOCATING WORKS LOCAL ROAD CLOSURE AND WORKS IN MEDIAN OATS ST & BANK ST
	ALUA-TGS-01-028	0	ARMADALE LINE UPGRADE ALLIANCE - EARLY WORKS SERVICE LOCATING WORKS LOCAL ROAD CLOSURE AND WORKS IN MEDIAN OATS ST & BANK ST
	ALUA-TMP-01-098	0	ARMADALE LINE UPGRADE ALLIANCE - EARLY WORKS TYPICAL PSP WORKS - TRAFFIC CONTROLLER (STOP SLOW) AND VERGE WORKS PSP >6m FROM ROAD EDGE
	ALUA-TMP-01-099	0	ARMADALE LINE UPGRADE ALLIANCE - EARLY WORKS TYPICAL PSP WORKS- AFTERCARE AND WORKS ON VERGE WITH REDUCED WIDTH PSP >6m FROM ROAD EDGE
Long Term Site Access	TGS Number	Rev	Details
Construction Stages	TGS Number	Rev	Details
Static Generics			

7.2 Sequence and Staging

The sequence of temporary traffic management installation, work activities and temporary traffic management removal are shown in the table below. All activities relating to installation, staging and removal of signage, lane closures and work activities shall be recorded in the Daily Diary detailing that the time at which they occur.

Step	Details
Set out	Advance warning signs shall be set out and installed first, followed by delineation and associated controls around the work site. Any detour signs where applicable should be erected prior to the activation of a road closure
Pack up	The removal of signs from site at the completion of a shift shall be performed in the reverse order of that noted above, with controls and devices in the immediate vicinity of the works to be removed from the road first in order to activate normal traffic flow as soon as possible, followed by the removal of advance warning signs.

Before work commences, signs and devices at approaches to the work area shall be erected in accordance with the adopted TGS, in the following order:

- Advance warning signs.
- All intermediate advance warning and regulatory signs and devices required in advance of the taper or start of the work area.
- All delineating devices required to form a taper including flashing arrow signs or temporary hazard markers where required.
- Delineation past the work area
- Other warning signs or regulatory signs.

Delineation devices such as cones and bollards should be placed in the same sequence, i.e. those furthest in advance of the work placed first.

Signs and devices that are erected before they are required shall be covered by a suitable material. The cover shall be removed immediately prior to the commencement of work.

Removal of traffic control signs and devices should be undertaken in the reverse order of erection, progressing from the work area out toward the approaches.

7.3 Traffic Control Devices

7.3.1 Sign Requirements

All signs used shall conform to the designs and dimensions as shown in AGTTM3 and the CoP.

Prior to installation, all signs and devices shall be checked by the Site Supervisor or a suitably qualified person to ensure that they are in good condition and meet the following requirements:

- Mechanical condition - Items that are bent, broken or have surface damage shall not be used.
- Cleanliness - Items should be free from accumulated dirt, road grime or other contamination.
- Colour of fluorescent signs - Fluorescent signs whose colour has faded to a point where they have lost their daylight impact shall be replaced.
- Retro reflectivity. - Signs for night-time use whose retro reflectivity is degraded either from long use or surface damage and does not meet the requirements of AS 1906 shall be replaced.
- Battery operated devices - shall be checked for lamp operation and battery condition.

Where signs do not conform either to the requirements of AGTTM3 or would fail to pass any of the above checks, they shall be replaced on notice.

Signs and devices shall be positioned and erected in accordance with the locations and spacing's shown on the drawings. All signs shall be positioned and erected such that:

- They are properly displayed and securely mounted;
- They are within the driver's line of sight;
- They cannot be obscured from view;
- They do not obscure other devices from the driver's line of sight;
- They do not become a possible hazard to workers or vehicles; and
- They do not deflect traffic into an undesirable path.

Signs and devices that are erected before they are required shall be covered by a suitable opaque material. The cover shall be removed immediately prior to the commencement of work.

Where there is a potential for conflict of information between existing signage and temporary signage erected for the purpose of traffic control, the existing signs shall be covered. The material covering the sign shall ensure that the sign cannot be seen under all conditions i.e. day, night and wet weather. Care will be taken to ensure existing signs are not damaged by the covering material or by adhesive tape.

7.3.2 Tolerances on positioning of signs and devices

Where a specific distance for the longitudinal positioning of signs or devices with respect to other items or features is stated, for the spacing of delineating devices or for the length of tapers or markings, the following tolerances may be applied:

(a) Positioning of signs, length of tapers or markings:

- i. Minimum, 10% less than the distances or lengths given.
- ii. Maximum, 25% more than the distances or lengths given.

(b) Spacing of delineating devices:

- i. Maximum, 10% more than the spacing shown.
- ii. No minimum.

These tolerances shall not apply where a distance, length or spacing is already stated as a maximum, a minimum or a range.

7.3.3 Flashing Arrow Signs

Where flashing arrow signs are required to better delineate lane tapers, these signs will comprise a matrix of lamps or light emitting elements in the form of an arrow that is flashed in a cyclical manner to provide advance warning. The sign shall have a minimum dimension of 2400 mm. x 1200 mm. and conform to the requirements of AS/NZS 4192. The Project Site Supervisor shall ensure that all equipment used meets the Australian Standard.

7.3.4 Delineation

Cones shall be used for delineation unless other treatment is specified in the Traffic Management Plan or on the Traffic Guidance Schemes. All cones shall be at least 700 millimetres in height and constructed from fluorescent orange or red material that is resilient to impact and will not damage vehicles when hit at low speed. Cones will be fitted with suitable white retro-reflective tape placed in accordance with AS1742.3, CoP and AGTTM.

Cones shall be designed to be stable under reasonably expected wind conditions and air turbulence from passing traffic.

The base of the cones will be secured so that they are not dislodged by traffic. Cones will be inspected at intervals necessary to ensure any misalignment or displacement is identified and corrected prior to this causing disruption to traffic.

Where specified, temporary frangible or otherwise non-hazardous delineator posts or bollards may be used for edge protection and taper delineation. Posts or bollards shall have a maximum dimension of 60 millimetres when measured along the longest side of a square or rectangular section or across the diameter of a circular section. Base design shall permit easy fixing to either sealed or unsealed surfaces and not intrude into traffic lanes greater than 50 millimetres from the face of the post or bollard.

All posts or bollards shall be erected in accordance with the Traffic Guidance Schemes. Posts and bollards shall be a minimum of 1000 mm. high, capable of being fixed to the road pavement by a suitable road adhesive or by fastening bolts or spikes. Fixing shall be in accordance with manufacturer's recommendations.

Posts and bollards shall be fitted with suitable white retro-reflective tape placed in accordance with AS1742.3, CoP and AGTTM.

All posts or bollards will be inspected daily and where displaced or missing made good immediately. All delineator posts are to be completely removed at the completion of all stages of construction and prior to the placement of asphalt surfacing. If adhesive is used to affix the posts this shall be completely removed from the road surface so that a flush surface is obtained.

Delineation spacing - Cones or bollards will be used to delineate the work area and travel path of vehicles. They shall be spaced according to the table on each TGS applicable to the speed of traffic and works being performed – as per the requirements outlined in AGTTM Part 3 – Section 5.4.1 and in Table 5.3.

7.4 Site Access for Work Vehicles

Construction and/or traffic management vehicles entering and exiting the traffic stream shall be mindful of the conditions that may affect the safety of these movements.

Access points shall be noted on the TGS and traffic controllers, work personnel and suppliers notified. Traffic Controllers may assist work vehicles enter and exit the work area.

All entry and exit movements will be in accordance with the Road Traffic Code and shall be undertaken in the following manner:

Vehicles shall:

- Decelerate slowly and signal their intention by indicator to leave the traffic stream.
- Activate the vehicle's rotating yellow lamp, where fitted, once a speed of 20 km/h. has been reached and at least 50m prior to the exit location.
- Switch on the vehicle hazard lights once the vehicle is stationary.
- Where risks associated with unassisted exit or entry to or from the traffic stream are high, Traffic Controllers should be used to assist entry and exit movements.

Vehicles fitted with rotating amber lamps shall have the vehicle's rotating lamp activated prior to entering the traffic stream and shall undertake the following.

- Switch off the vehicle hazard lights.
- Indicate intention to enter the traffic stream using direction indicators.
- Ensure there is a suitable gap from oncoming traffic to allow for a safe entry maneuver; and,
- Turn off the rotating yellow lamp(s) once a speed of 40 km/h is reached.

Entry and exit maneuvers shall be avoided in close proximity to intersections. Work personnel shall not cross traffic streams on foot unless absolutely necessary.

Construction or traffic management vehicles shall only be parked where indicated on the Traffic Guidance Scheme. Vehicles shall not obstruct paths and be parked an adequate distance from intersections or driveways to ensure clear sight lines remain for all road users.

7.5 Communicating TMP Requirements

TMP requirements shall be communicated to all relevant work personnel prior to the commencement of works, generally at the pre-start meeting.

8 EMERGENCY ARRANGEMENTS AND CONTINGENCIES

8.1 Traffic Incident Procedures

In the event of an incident or accident, whether or not involving traffic or road users, all work shall cease, and traffic shall be stopped as necessary to avoid further deterioration of the situation. First Aid shall be administered as necessary, and medical assistance shall be called for if required.

Road plant within the work area that may impact on any services requiring access to a crash site will be cleared from the area quickly as necessary.

8.1.1 Serious Injury or Fatality

In the case of serious injury or fatality occurring within the traffic management site all work shall cease immediately, machinery and vehicles turned off and the area cleared of personnel as soon as possible. Traffic Controllers (and other personnel if necessary) shall be deployed immediately to ensure no traffic or other road users approach the area.

An Ambulance and Police shall be called on telephone number 000 where life threatening injuries are apparent.

All road workers and traffic management personnel shall preserve the scene leaving everything in situ, until direction is given by Police or WorkSafe.

A site-specific detour route and/or road closure point will be determined, signed and controlled by traffic management personnel and advised to Police, who will take charge of the site upon arrival (see last paragraph).

Detour routes will be determined so as to cater for all types of vehicles required to use them (see last paragraph). An example of how to manage an emergency can be found in AGTTM Part 10 – Section 5.

All site personnel shall be briefed on control procedures covering incidents and crashes that result in serious injury or fatalities.

8.1.2 Minor Incident or Vehicle Break Down within Site

Broken down vehicles and vehicles involved in minor non-injury crashes shall be temporarily moved to the verge as soon as possible after details of the crash locations have been gathered and noted. Where necessary to maintain traffic flow, vehicles shall be temporarily moved into the closed section of the work area behind the cones, providing there is no risk to vehicles and their occupants or workers. Suitable recovery systems shall be used to facilitate prompt removal of broken down or crashed vehicles. Assistance shall be rendered to ensure the impact of the incident on the network is minimised.

Any traffic crash resulting in non-life-threatening injury shall be reported to the WA Police Service on 131 444.

Details of all incidents and accidents shall be reported to the Site Supervisor and Project Manager using the incident report form at Appendix “C” (or similar).

8.2 Emergency Services

Emergency services shall be notified of the proposed works nature, location, date and times as well as contact details for the site supervisor.

On-site traffic controllers will be equipped with mobile communications to advise and/or liaise with emergency services to ensure a prompt response should the need arise.

8.3 Dangerous Goods

Should any incident arise involving vehicles transporting dangerous goods, all work shall cease immediately, machinery and vehicles turned off and the area cleared of personnel as soon as possible. Traffic Controllers (and other personnel if necessary) shall be deployed immediately to ensure no traffic or other road users approach the area.

Emergency services shall be notified of the proposed works nature, location, date and times as well as contact details for the site supervisor. All site personnel shall be briefed on evacuation and control procedures.

8.4 Damage to Services

In the event that gas services are damaged, all work shall cease immediately, machinery and vehicles turned off and the area cleared of personnel as soon as possible. Traffic Controllers (and other personnel if necessary) shall be deployed immediately to ensure no traffic or other road users approach the area. The Police Service and relevant supply authority shall be called immediately. Damage to any other services shall be treated in a similar manner except machinery may remain operational and access may be maintained where it is safe to do so.

All site personnel shall be briefed on evacuation and control procedures.

8.5 Failure of Services

8.5.1 Failure of Traffic Signals

In the event of failure of traffic signals, the Police should be contacted immediately and Traffic Controllers (and other personnel if necessary) shall be deployed immediately to secure the site and assist vehicle movements until the Police arrive. RNOC (Road Network Operation Centre) are to be notified of the failed traffic signals to try rectifying the situation.

8.5.2 Failure of Street lighting

In the event that street lighting is damaged and fails to operate or operates incorrectly, Traffic Controllers (and other personnel if necessary, with appropriate temporary lighting) shall be deployed immediately if the lighting failure adversely affects road user safety to control traffic movements as required. Western Power shall be notified immediately.

8.5.3 Failure of Power

In the event that power infrastructure is damaged and poses a risk through live current, Traffic Controllers (and other personnel if necessary) shall be deployed immediately to secure the site and prevent entry to the area affected by live power. Western Power shall be notified immediately (phone 13 13 51).

8.6 Emergency Contacts

In the event of an emergency the following relevant authorities must be contacted and advised of nature of works, location, type of emergency and contact details for the site supervisor.

Emergency Service	E-mail/Website	Phone (Emergency)
WA Police Service	State.Traffic.Intelligence.Planning.&.Co-ordination.Unit@police.wa.gov.au	000
St. John Ambulance	ambulanceoperations@stjohnambulance.com.au	000
DFES	www.dfes.wa.gov.au/contactus/pages/dfesoffices.aspx	000
Power	http://www.westernpower.com.au/customerservice/contactus/	13 13 51
Gas	enquiries@atcogas.com.au	13 13 52
Water	https://www.watercorporation.com.au/about-us/contact-us	13 13 75

9 MONITORING AND MEASUREMENT

9.1 Daily Inspections

Prior to works commencing the Site Supervisor shall undertake to communicate the Traffic Management Plan to all key stakeholders and affected parties.

On completion of setting out the traffic control measures, the site is to be monitored for a suitable period of time. If traffic speeds on the approaches to the work site are assessed as being above the temporary posted speed zone for the work site, the Site Supervisor is to initiate action to modify the approach signage and tapers in accordance with the requirements of AGTTM / CoP. All such actions are to be recorded in the Daily Diary. Should road users be observed to continue to travel in excess of the posted speed limit, the police may be requested to attend the site to enforce the temporary posted speed limit.

The Advanced Worksite Traffic Management accredited supervisory person at the worksite may conditionally approve changes made to a complex traffic management plan subject to review and endorsement of the change by an RTM as soon as practicably possible.

The Traffic Management Contractor shall ensure that all temporary signs, devices and controls are maintained at all times. To achieve this, procedures in line with the requirements outlined in AGTTM Part 6 will be instituted. The monitoring program shall incorporate inspections:

- Before the start of work activities on site,
- During the hours of work,
- Closing down at the end of the shift period, and
- After hours.

A daily record of the inspections shall be kept indicating:

- When traffic controls were erected,
- When changes to controls occurred and why the changes were undertaken,
- Any significant incidents or observations associated with the traffic controls and their impacts on road users or adjacent properties.

The Traffic Management Contractor shall ensure that personnel are assigned to monitor the traffic control scheme. Inspections shall at least satisfy the following requirements.

9.1.1 Before works start

- Confirm TMP and TGS are suitable for the day's activities;
- Inspect all signs and devices to ensure they are undamaged, clean and comply with the requirements depicted on the TGS;
- All lamps should be checked and cleaned as necessary;

- After any adjustments have been made to the signs and devices, conduct a drive through inspection to confirm effectiveness.

9.1.2 During work hours

- Designate and ensure that appropriate work personnel drive through the site periodically to inspect all signs and devices and ensure they are undamaged and comply with the requirements depicted on the Traffic Guidance Schemes;
- Attend to minor problems as they occur;
- Conduct on the spot maintenance/repairs as required;
- When traffic controllers are on the job, ensure they remain in place at all times. Relieve controllers as necessary to ensure attentiveness is retained;
- During breaks or changes in work activities remove or cover any signs that do not apply (e.g. PREPARE TO STOP, Workers symbolic);
- Re-position signs and devices as required by work processes throughout the day and keep records of any changes.

9.1.3 Closing down each day

- Conduct a pre-close down inspection, allowing time for any appropriate maintenance works;
- Remove any unnecessary signage (e.g. Prepare to Stop, Symbolic Workers);
- Replace any unnecessary signage with appropriate delineation;
- Install barriers and lights where required;
- Drive through site and confirm all signs and devices are operating correctly with no misleading visual cues;
- Record details of inspection and any changes made to layout.

9.1.4 After hours

- Appoint personnel to conduct after dark checks. Replace any signs / devices not working, missing or damaged and record in diary.
- Appoint personnel to conduct checks on non-work days (e.g. weekends). Replace any signs / devices not working, missing or damaged and record in diary.
- The frequency of inspections needs to align with the amount of traffic management on site, weather conditions, vehicle types and volumes, road user behaviour and site specific risks.

9.2 TMP Audits and Inspections

One compliance audit (using the 'Compliance Audit Checklist for Traffic Management for Works on Roads' – found on the MRWA website) should be conducted following setting up of the traffic management and prior to commencement of the works.

Audit findings, recommendations and actions taken shall be documented and copies forwarded to the Project Manager and the Road Authority's Representative.

9.3 Records

A daily diary recording all inspections including variations to the approved TMP shall be kept using the Daily Diary.

The Traffic Supervisor is to record all inspections made on a daily basis and at those times prescribed by the Traffic Management Implementation Standards. Upon completion of each day the Traffic Supervisor shall provide copies of the daily diary record to the Project Manager.

The Traffic Supervisor is to record all variations made to the approved Traffic Management Plan on a daily basis and clearly indicate the nature of the variations and the reason for the variations. Upon completion of each day the Traffic Supervisor shall provide copies of the variation record to the Project Manager.

9.4 Public Feedback

Any feedback received from the public will be directed back to the Project management team for action and follow up as required.

10 MANAGEMENT REVIEW AND APPROVALS

10.1 TMP Review and Improvement

The traffic management team shall assess all results from measurement and evaluations and ensure that all CARs, NCRs, incidents and feedback are properly addressed and responded to timely and appropriately.

10.2 Variations

If applicable see Appendix B.

10.3 Approvals

Before works commence it is necessary to seek approval from the following:

- PTA

APPENDIX A - NOTIFICATION OF ROAD WORKS

N/A for Stage 1 early exploration works, Notification will be updated and issued as required for evolving works scope that will be detailed in later iterations of this TMP.

NOTE:

The Notification of Roadworks form shall be filled out and distributed if the works associated with this TMP meet any of the requirements outlined in MRWA Code of Practice section 5.4:

- Works involving the complete closure of any road.
- Works on primary and district distributor roads of more than four (4) hours duration where it is expected that major traffic delays and congestion will occur.
- Works on any road where speed restrictions and lane closures will be in place more than five (5) days, but major traffic delays are not expected.
- Traffic management activities involving the establishment of a contra-flow.
- Traffic management activities resulting in any direct or indirect changes to traffic flows and/or traffic composition on bridges, including situations where such changes are a result of lane closures or traffic detours.
- Works on any primary or district distributor road where construction activities will make it difficult or impossible for the passage of general access or oversize vehicles, and traffic control devices cannot be easily shifted on a temporary basis to allow the vehicle to pass.
- Works between hold-lines on signalised intersections where work will last longer than one (1) hour, or a lesser time if significant delay and congestion will occur.
- Works impacting on the operation of any Crossing Attended Warden controlled children's crossing.

APPENDIX B - VARIATION TO STANDARDS

APPLICATION FOR APPROVAL TO VARY REQUIREMENTS OF AGGTM3, OR MRWA TRAFFIC MANAGEMENT CODES OF PRACTICE

Form Instruction

- Section A** – Identify the Principal Agency / person commissioning the activity. (Does not include contractors, subcontractors or traffic management company/traffic planners etc).
- Section B** – Identify activity location, start / finish date and time, type of traffic management, description location of activity.
- Section C** – Identify the person that has prepared the Traffic Management Plan, this person shall have AWTM accreditation.
- Section D** – For Works undertaken on a State road or on behalf of Main Roads Western Australia the details of the risk assessment process identified in this application form must be documented and endorsed¹ by an accredited Roadworks Traffic Manager.

All applications to be addressed to the applicable Main Roads Regional office. For contact information please refer to the online Application kits and guidelines to undertake works. (www.mainroads.wa.gov.au >Our Roads > Conducting Works on Roads).

For all other applications the details of the risk assessment process identified in this application form must be documented and endorsed¹ by the person responsible for approving the traffic management plan.

Contact with the appropriate road authority should be made prior to lodgment of this application to determine its suitability and for any additional requirements.

- Section E** - Risk implication, identification and assessment process must be undertaken in accordance with Risk Management – Principles and Guidelines AS/NZS ISO 31000. The likelihood and consequences should be rated after the application of any additional counter measures taken utilising Tables from Annexure's 202B and 203B, Main Roads WA - Specification 202 and 203 respectively.

Incomplete or applications not signed by the RTM¹ will not be processed.

A	Applicant (Principal for the Works)					
	Postal address					
	Suburb		State		Postcode	
	Project Manager				Telephone	
	Email				Facsimile	

B	Anticipated start date			Anticipated finish date		
	Daily work hours; From		To		Weekend work applicable	Yes <input type="checkbox"/> Sat <input type="checkbox"/> Sun <input type="checkbox"/> No <input type="checkbox"/>
	Location of works (Road/Street Suburb),					
	Road type (eg undivided, two lane)					
	Description of works					
	Are alterations to permanent traffic signals required?	Yes <input type="checkbox"/>		No <input type="checkbox"/>		N/A <input type="checkbox"/>
	Posted Speed Limit		Worksite speed limit		After hours speed limit	

¹ A person with AWTM accreditation is permitted to endorse a variation of less than 135 % of the allowable lane capacity as outlined in AGTTM3. See section 5.6 of the Code of Practice

C	TMP Designer						
	Accreditation Number						
	Postal address						
	Suburb		State		Postcode		
	Email		Telephone		Facsimile		
	Endorsement signature					Date	

D	RTM Endorsing Variation ¹						
	Accreditation Number						
	Postal address						
	Suburb		State		Postcode		
	Email		Telephone		Facsimile		
	Endorsement signature ¹					Date	

For Internal Use Only							
Approving Road Authority							
Approving Officer Position							
Application Approved		Yes <input type="checkbox"/>	No <input type="checkbox"/>	If Not Why Not			
Additional Conditions							
Approved By: Signature		Title		Date		File	

E	Description of Variation Requested	Specify Point of Departure from Standard / AGTMM / Code of Practice (List section and page number)	Justification (Why is this necessary)	Additional Counter Measures To Be Taken (Identify additional counter measures to be used to negate the lesser treatment)	Residual Risk ²		
					L	C	RR

² Note: the risk assessment in the TMP also needs to record the variation and include the risk event, pre-treatment risk, treatment and residual risk.

APPENDIX C - RECORD FORMS

Daily Diary Daily Traffic Management Diary

Location: _____		Client: _____		Date: _____	
TMP No: _____	TGS No: _____	Weather Conditions: _____		Diary Sheet: _____	of _____
Start Time at Depot: _____	Time Arrive Onsite: _____	Commencement of Site Setup: _____		Site Setup and Operational: _____	
Site Pulled Down at: _____	Time Aftercare signs setup: _____	TGS No: _____	Time left site: _____	Finish time at Depot: _____	
<input type="checkbox"/> Day Works	<input type="checkbox"/> Night Works	<input type="checkbox"/> Emergency Response	Site Setup as per TGS <input type="checkbox"/> Yes <input type="checkbox"/> No (if not comment on next page)		
<input type="checkbox"/> Attendance at Pre-Start Meeting	Did an incident occur (if yes complete incident report form) <input type="checkbox"/> Yes <input type="checkbox"/> No				

I confirm that the above times of 'setup' and 'pulldown' of traffic management signs and devices are a true and correct

Name (Site Supervisor): _____ Signed: _____

Drive Through Checks (Checks must be conducted at least every 2 hours)

Time of check entered. Rule off and leave blank if the check does not apply to the site. Make a note of any issues on the next page.

Traffic Management Site Checks	1	2	3	4	5	6	7	8	9	10
Time										
Are signs upright, clean, visible, level & stable										
Are taper lengths correct										
Are speed limit signs correct and doubled up										
Are sign spacings correct										
Are cone/bollard alignments straight & spaced correctly										
Are devices operating correctly										
Have pedestrians been catered for										
Are lane widths adequate										
Are vehicle queue lengths acceptable										
Is road surface condition adequate										

No. of Traffic Management Vehicles Onsite: _____ No. of Traffic Management Personnel Onsite: _____

Traffic Management Personnel Names & Accreditations:

Position	Name	Accreditation Details	Time of Break from Stop/Slow (Traffic controllers must have a 15 minute break every two hours of constant stop/slow operation)							
			On	Off	On	Off	On	Off	On	Off
Crew Leader:			:	:	:	:	:	:	:	:
Traffic Controller:			:	:	:	:	:	:	:	:
Traffic Controller:			:	:	:	:	:	:	:	:
Traffic Controller:			:	:	:	:	:	:	:	:
Traffic Controller:			:	:	:	:	:	:	:	:
Traffic Controller:			:	:	:	:	:	:	:	:

Additional Comments _____

I confirm that the details contained herein are true and correct

Name: (Traffic Management Crew Leader): _____ Signed: _____

Incident Report Form

Any incident occurring onsite shall be reported using the following incident report format.

Region Contract Number	Incident Report No. Contractor
-------------------------------	---------------------------------------

Major Incident Reports must be forwarded to the Superintendent within 48 hours of the incident occurring or becoming apparent.

Contractors shall use this Form for reporting of Traffic incidents on works under Contract and this form supplements the OSH Incident Reporting Form.

A Details of Incident		Reported to: <input type="checkbox"/> Supervisor <input type="checkbox"/> TMR <input type="checkbox"/> Other		
OSH Incident Report No		Atmospheric Conditions		Light Conditions
Fatality <input type="checkbox"/>		Clear <input type="checkbox"/>		Day Light <input type="checkbox"/>
Injury <input type="checkbox"/>	Road Surface	Overcast <input type="checkbox"/>		Night Time <input type="checkbox"/>
Property Damage <input type="checkbox"/>	Unsealed <input type="checkbox"/>	Raining <input type="checkbox"/>		Dawn/Dusk <input type="checkbox"/>
Police Attended Yes/No	Sealed <input type="checkbox"/>	Fog/Smoke/Dust <input type="checkbox"/>		Street Lighting
Time and Date of incident	AM / PM		Road Condition	On <input type="checkbox"/>
	Day	Month	Year	Off <input type="checkbox"/>
				Not Provided <input type="checkbox"/>
Other relevant details, (Last maintenance grade, watering and dust conditions):				
B Details of Traffic Management in place:				
TGS No:		Name of individual that prepared the TGS		
Time last inspected:		Accreditation No:		
TGS Approved:	Day	Month	Year	TMP Approved: Day Month Year
C Descriptions of Vehicles:				
Detail (make, model/ped/cyclist/VRU)		Registration No	Direction of Travel	Age of Driver
Vehicle 1				
Vehicle 2				
Vehicle 3				
Comments:				

D Description of Incident:											
Draw the incident including the direction of travel, traffic control signs, fixed structures and north point.											
											

E Attachments:	The following copies MUST be submitted with this Incident Report.	
Approved TMP <input type="checkbox"/> Approved TCP <input type="checkbox"/> Approvals for temporary speed restrictions <input type="checkbox"/> Daily Diary <input type="checkbox"/> <input type="checkbox"/>		

F Police Report:						
Accident reported to Police:	<input type="checkbox"/> YES	<input type="checkbox"/> NO	Report made by	<input type="checkbox"/> Phone	<input type="checkbox"/> Fax	<input type="checkbox"/> Mail or E-mail
Date Report Made	Day	Month	Year	Police WA Reference Number		

G Details of Person Completing this Incident Form:	
Name:	Contractor Name:
Position:	
Date:	Signature:

APPENDIX D - TRAFFIC ANALYSIS AND VOLUME COUNTS

SEVENOAKS STREET - WEEKDAYS



SITE 2642

Hourly Volume

Sevenoaks St (1140011)

2021/22

Monday to Friday

North of Wharf St (SLK 2.33)

	All Vehicles				Heavy Vehicles				
	NB	SB	Both	NB	SB	Both	%		
00:00	38	28	66	1	1	2	3.0		
01:00	21	18	39	1	1	2	5.1		
02:00	8	11	19	0	1	1	5.3		
03:00	8	22	30	1	1	2	6.7		
04:00	19	41	60	3	2	5	8.3		
05:00	61	173	234	4	11	15	6.4		
06:00	128	346	474	16	26	42	8.9		
07:00	234	591	825	22	42	64	7.8		
08:00	434	614	1048	38	41	79	7.5		
09:00	338	423	761	31	34	65	8.5		
10:00	317	421	738	30	45	75	10.2		
11:00	347	431	778	33	41	74	9.5		
12:00	390	464	854	36	45	81	9.5		
13:00	386	485	871	29	45	74	8.5		
14:00	520	520	1040	38	42	80	7.7		
15:00	719	554	1273	38	40	78	6.1		
16:00	806	593	1399	48	31	79	5.6		
17:00	724	542	1266	27	22	49	3.9		
18:00	435	364	799	12	10	22	2.8		
19:00	260	300	560	6	10	16	2.9		
20:00	203	227	430	4	6	10	2.3		
21:00	167	159	326	4	4	8	2.5		
22:00	128	95	223	3	2	5	2.2		
23:00	88	63	151	3	2	5	3.3		
TOTAL	6779	7485	14264	428	505	933	6.5		



Peak Statistics

AM	TIME	08:15	07:30	08:00	08:00	07:15	11:45
	VOL	444	647	1048	38	48	82
PM	TIME	16:15	15:45	16:15	48	47	83
	VOL	814	595	1402			

Volume

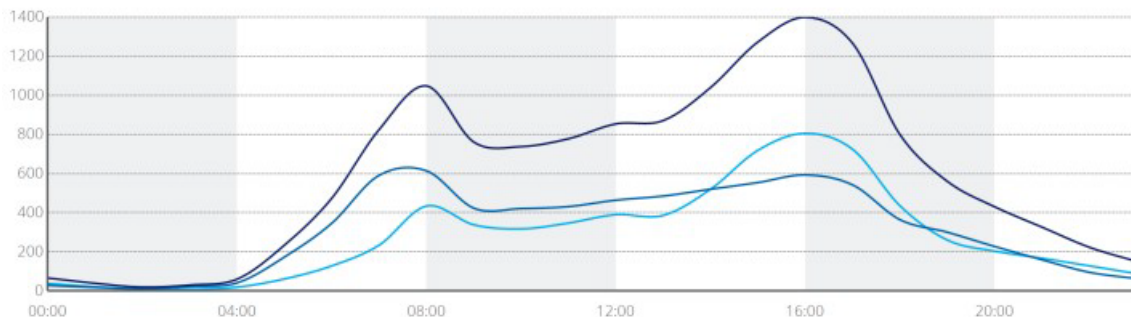

— Northbound — Southbound — Both Directions

SEVENOAKS STREET - WEEKEND



SITE 2642

Hourly Volume

Sevenoaks St (1140011)
North of Wharf St (SLK 2.33)

2021/22
Weekend

	All Vehicles				Heavy Vehicles				
	NB	SB	Both	NB	SB	Both	%		
00:00	73	59	132	1	2	3	2.3		
01:00	51	31	82	2	0	2	2.4		
02:00	33	20	53	0	1	1	1.9		
03:00	21	23	44	1	0	1	2.3		
04:00	21	22	43	1	1	2	4.7		
05:00	26	78	104	0	3	3	2.9		
06:00	53	103	156	4	5	9	5.8		
07:00	81	112	193	4	3	7	3.6		
08:00	179	204	383	6	7	13	3.4		
09:00	265	308	573	9	6	15	2.6		
10:00	329	364	693	11	11	22	3.2		
11:00	434	429	863	14	16	30	3.5		
12:00	445	467	912	12	13	25	2.7		
13:00	445	511	956	11	17	28	2.9		
14:00	411	459	870	12	17	29	3.3		
15:00	402	457	859	14	13	27	3.1		
16:00	346	490	836	9	10	19	2.3		
17:00	307	516	823	11	16	27	3.3		
18:00	265	325	590	6	7	13	2.2		
19:00	225	233	458	6	8	14	3.1		
20:00	180	181	361	3	7	10	2.8		
21:00	160	152	312	1	3	4	1.3		
22:00	143	91	234	2	4	6	2.6		
23:00	105	76	181	3	3	6	3.3		
TOTAL	5000	5711	10711	143	173	316	3.0		



Peak Statistics

AM	TIME	11:15	11:45	11:45	11:45	11:15	11:15
	VOL	467	479	929	15	17	31
PM	TIME	12:45	16:30	13:00	15:15	14:30	14:00
	VOL	452	564	956	15	17	29

Volume

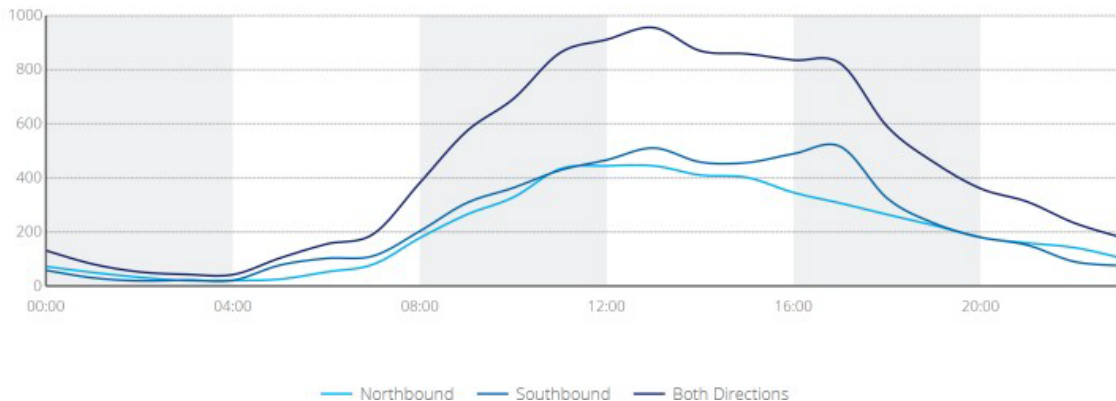

SEVENOAKS STREET – HAMILTON STREET LM 0640

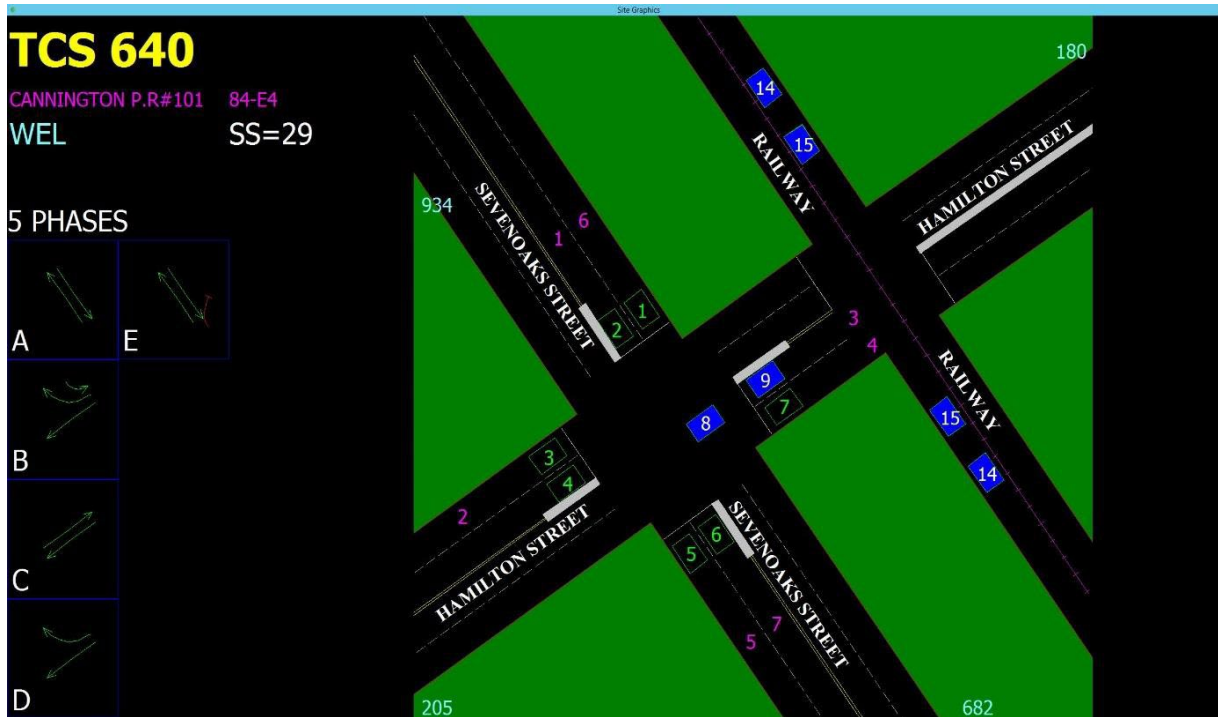

	Weekday Average							
	Sevenoaks St				Hamilton St			
	Northbound		Southbound		Eastbound		Westbound	
	Before Signals	After Signals	Before Signals	After Signals	Before Signals	After Signals	Before Signals	After Signals
0:00 - 1:00	33	25	42	37	12	18	16	23
1:00 - 2:00	18	14	19	17	6	8	9	13
2:00 - 3:00	20	15	20	15	3	8	6	11
3:00 - 4:00	21	17	16	13	7	9	9	13
4:00 - 5:00	46	38	19	25	16	20	29	28
5:00 - 6:00	181	145	58	77	66	73	89	99
6:00 - 7:00	321	260	129	159	112	129	173	188
7:00 - 8:00	517	448	236	302	232	223	349	362
8:00 - 9:00	515	486	360	511	272	260	604	493
9:00 - 10:00	361	312	290	337	146	173	319	295
10:00 - 11:00	339	278	269	302	107	144	273	264
11:00 - 12:00	360	294	314	319	119	168	251	263
12:00 - 13:00	375	308	325	344	140	181	271	278
13:00 - 14:00	362	301	342	358	129	172	286	288
14:00 - 15:00	424	359	409	459	169	207	389	365
15:00 - 16:00	441	399	582	640	227	260	504	455
16:00 - 17:00	462	402	619	644	193	245	479	463
17:00 - 18:00	421	347	592	562	155	215	341	386
18:00 - 19:00	312	251	346	337	103	145	225	253
19:00 - 20:00	263	205	251	245	82	118	162	190
20:00 - 21:00	198	155	216	198	65	104	114	136
21:00 - 22:00	129	105	194	174	62	85	81	102
22:00 - 23:00	83	70	134	120	43	58	58	70
23:00 - 24:00	57	45	72	63	21	32	31	41

Traffic Management Plan

	Weekend Average							
	Sevenoaks St				Hamilton St			
	Northbound		Southbound		Eastbound		Westbound	
	Before Signals	After Signals	Before Signals	After Signals	Before Signals	After Signals	Before Signals	After Signals
0:00 - 1:00	51	39	41	41	19	26	26	30
1:00 - 2:00	23	18	24	27	10	14	20	17
2:00 - 3:00	21	14	22	21	9	12	9	11
3:00 - 4:00	17	15	19	17	10	12	11	12
4:00 - 5:00	31	22	18	18	8	12	13	16
5:00 - 6:00	74	58	30	37	21	26	40	44
6:00 - 7:00	106	91	56	68	33	41	87	81
7:00 - 8:00	123	107	96	109	54	63	104	97
8:00 - 9:00	173	148	134	165	57	70	174	154
9:00 - 10:00	273	222	181	225	92	105	222	215
10:00 - 11:00	318	252	265	274	96	132	213	233
11:00 - 12:00	350	275	288	307	93	142	254	258
12:00 - 13:00	345	272	319	324	96	145	244	261
13:00 - 14:00	358	271	288	282	84	134	198	241
14:00 - 15:00	349	264	294	289	90	136	196	239
15:00 - 16:00	320	250	311	299	99	143	191	230
16:00 - 17:00	356	272	265	268	90	134	203	239
17:00 - 18:00	333	253	236	238	97	136	169	206
18:00 - 19:00	225	187	164	191	85	110	180	166
19:00 - 20:00	203	175	182	202	93	113	174	161
20:00 - 21:00	167	139	161	160	74	94	111	119
21:00 - 22:00	105	93	138	137	69	82	85	84
22:00 - 23:00	88	73	114	111	48	58	61	68
23:00 - 24:00	67	52	63	61	29	35	34	44

SEVENOAKS STREET – CECIL AVENUE STREET LM 0542

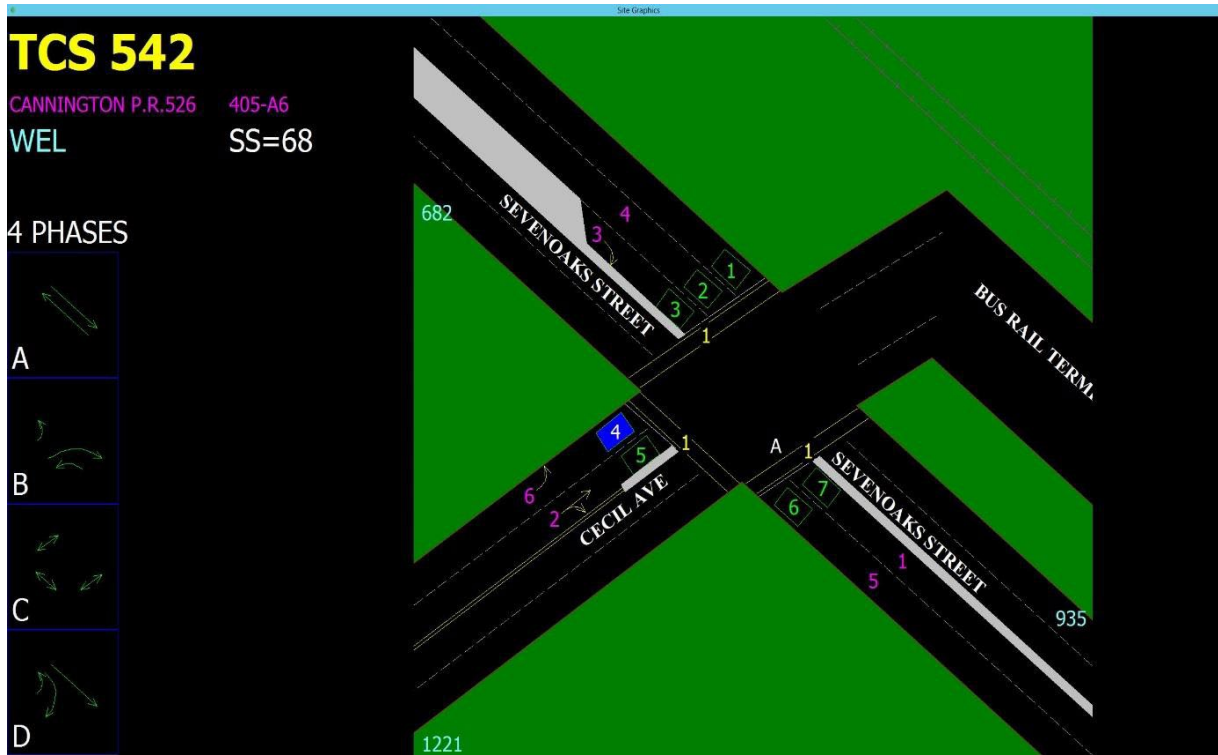

	Weekday Average							
	Sevenoaks St				Ceicel Ave/Bus			
	Northbound		Southbound		Eastbound		Westbound	
	Before Signals	After Signals	Before Signals	After Signals	Before Signals	After Signals	Before Signals	After Signals
0:00 - 1:00	17	19	30	26	10	3	0	9
1:00 - 2:00	11	12	16	15	6	2	0	5
2:00 - 3:00	10	11	13	12	5	2	0	4
3:00 - 4:00	9	9	8	7	3	1	0	3
4:00 - 5:00	42	36	22	20	7	3	0	12
5:00 - 6:00	171	144	62	56	25	12	0	46
6:00 - 7:00	322	262	124	96	50	28	0	110
7:00 - 8:00	509	443	193	137	111	47	0	185
8:00 - 9:00	513	497	379	245	183	55	0	279
9:00 - 10:00	337	326	317	205	137	44	0	215
10:00 - 11:00	313	296	283	189	125	42	0	194
11:00 - 12:00	328	326	298	191	139	43	0	206
12:00 - 13:00	342	342	304	206	148	45	0	202
13:00 - 14:00	325	357	347	240	174	44	0	205
14:00 - 15:00	395	425	417	296	198	49	0	239
15:00 - 16:00	412	426	568	409	203	61	0	286
16:00 - 17:00	439	447	612	455	206	64	0	293
17:00 - 18:00	378	401	518	409	207	63	0	230
18:00 - 19:00	255	292	294	218	171	46	0	164
19:00 - 20:00	190	206	217	176	113	34	0	105
20:00 - 21:00	132	171	154	132	97	21	0	59
21:00 - 22:00	106	117	123	102	60	16	0	55
22:00 - 23:00	57	68	93	84	43	12	0	29
23:00 - 24:00	33	38	51	47	23	7	0	16

Traffic Management Plan

	Weekend Average							
	Sevenoaks St				Ceicel Ave/Bus			
	Northbound		Southbound		Eastbound		Westbound	
	Before Signals	After Signals	Before Signals	After Signals	Before Signals	After Signals	Before Signals	After Signals
0:00 - 1:00	27	29	34	32	15	5	0	11
1:00 - 2:00	12	13	26	24	10	4	0	7
2:00 - 3:00	10	11	16	13	5	1	0	6
3:00 - 4:00	7	6	8	7	2	1	0	3
4:00 - 5:00	19	16	8	7	2	1	0	5
5:00 - 6:00	42	34	27	22	6	3	0	15
6:00 - 7:00	77	66	49	37	16	5	0	34
7:00 - 8:00	110	100	79	54	31	9	0	57
8:00 - 9:00	145	149	151	87	64	16	0	107
9:00 - 10:00	225	233	197	123	107	27	0	145
10:00 - 11:00	229	270	274	164	142	27	0	184
11:00 - 12:00	263	307	292	166	159	31	0	209
12:00 - 13:00	286	356	326	205	199	38	0	212
13:00 - 14:00	265	324	283	195	177	35	0	171
14:00 - 15:00	296	334	280	190	161	35	0	177
15:00 - 16:00	258	305	289	189	164	33	0	183
16:00 - 17:00	263	333	229	156	189	34	0	157
17:00 - 18:00	238	279	202	143	141	30	0	128
18:00 - 19:00	168	181	153	115	92	23	0	93
19:00 - 20:00	146	162	134	101	87	21	0	82
20:00 - 21:00	102	127	120	82	73	15	0	69
21:00 - 22:00	88	91	89	77	48	18	0	39
22:00 - 23:00	51	62	76	59	38	11	0	32
23:00 - 24:00	38	45	55	46	26	6	0	20

OATS STREET WEEKDAY



SITE 1412

Hourly Volume

Oats St (1290117)

2016/17
Monday to Friday

South of Rutland Av (SLK 1.41)

	All Vehicles			Heavy Vehicles			
	NB	SB	Both	NB	SB	Both	%
00:00	27	24	51	0	0	0	0.0
01:00	18	25	43	0	1	1	2.3
02:00	8	14	22	0	1	1	4.5
03:00	10	16	26	2	4	6	23.1
04:00	23	21	44	1	2	3	6.8
05:00	81	84	165	5	6	11	6.7
06:00	165	216	381	19	20	39	10.2
07:00	295	469	764	24	37	61	8.0
08:00	410	582	992	26	40	66	6.7
09:00	336	470	806	28	37	65	8.1
10:00	333	396	729	28	39	67	9.2
11:00	354	411	765	30	37	67	8.8
12:00	345	464	809	27	45	72	8.9
13:00	385	429	814	24	31	55	6.8
14:00	396	499	895	23	32	55	6.1
15:00	534	546	1080	28	31	59	5.5
16:00	560	558	1118	23	20	43	3.8
17:00	488	476	964	20	11	31	3.2
18:00	317	354	671	10	11	21	3.1
19:00	226	250	476	9	10	19	4.0
20:00	189	171	360	6	2	8	2.2
21:00	151	147	298	6	2	8	2.7
22:00	102	101	203	3	3	6	3.0
23:00	59	63	122	1	2	3	2.5
TOTAL	5812	6786	12598	343	434	767	6.1



Peak Statistics

AM TIME	08:15	07:45	07:45	08:45	07:30	08:15
VOL	416	616	1015	32	44	72
PM TIME	16:00	16:00	16:00	15:15	12:15	12:15
VOL	560	558	1118	29	45	72

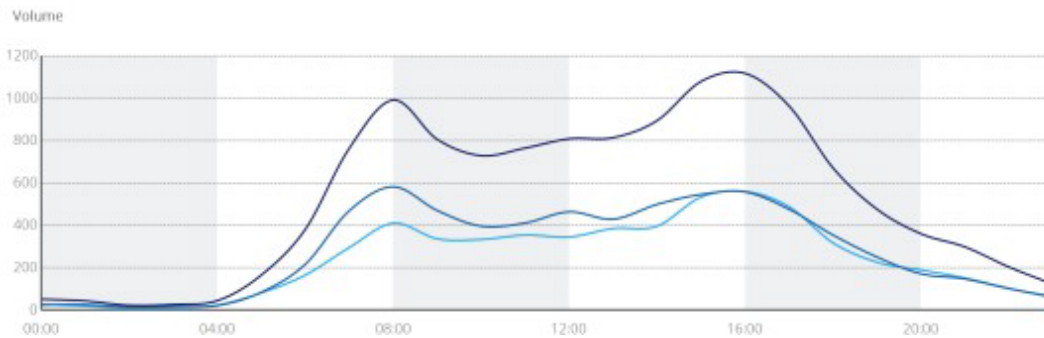

OATS STREET WEEKEND



SITE 1412

Hourly Volume

Oats St (1290117)

2016/17
Weekend

South of Rutland Av (SLK 1.41)

	All Vehicles			Heavy Vehicles				
	NB	SB	Both	NB	SB	Both	%	
00:00	61	54	115	6	3	9	7.8	
01:00	32	24	56	1	0	1	1.8	
02:00	24	22	46	1	0	1	2.2	
03:00	19	25	44	0	2	2	4.5	
04:00	26	23	49	0	2	2	4.1	
05:00	24	30	54	3	0	3	5.6	
06:00	58	84	142	4	7	11	7.7	
07:00	96	142	238	8	7	15	6.3	
08:00	213	247	460	5	11	16	3.5	
09:00	290	361	651	16	11	27	4.1	
10:00	320	405	725	13	18	31	4.3	
11:00	391	489	880	11	20	31	3.5	
12:00	397	429	826	10	18	28	3.4	
13:00	368	394	762	13	8	21	2.8	
14:00	329	338	667	9	8	17	2.5	
15:00	290	356	646	7	11	18	2.8	
16:00	323	322	645	7	10	17	2.6	
17:00	275	371	646	12	10	22	3.4	
18:00	232	309	541	7	3	10	1.8	
19:00	188	178	366	10	5	15	4.1	
20:00	148	142	290	3	3	6	2.1	
21:00	136	133	269	6	0	6	2.2	
22:00	132	103	235	3	1	4	1.7	
23:00	94	99	193	3	1	4	2.1	
TOTAL	4466	5080	9546	158	159	317	3.3	



Peak Statistics

AM	TIME	11:45	11:00	11:00	09:15	10:15	10:45
	VCL	401	489	880	18	24	37
PM	TIME	12:00	12:00	12:00	13:30	12:15	12:00
	VCL	397	429	826	13	18	28

Volume

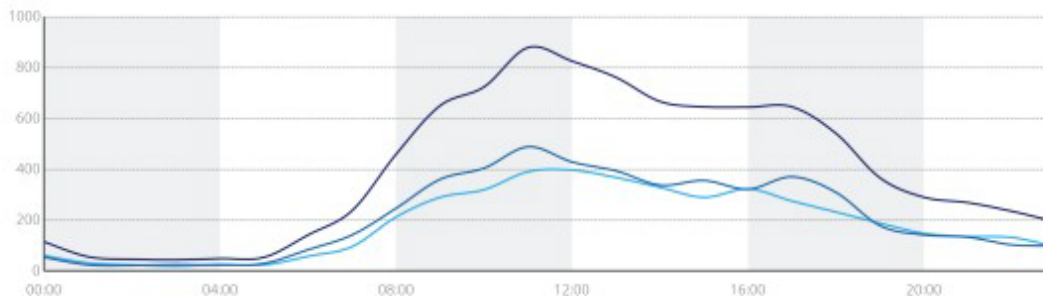

ARMADALE LINE UPGRADE ALLIANCE

Innovation to Reality

Traffic Management Strategy Heavy Haulage



Acknowledgement of Country

ALUA acknowledges the people of the Noongar Nation as Traditional Custodians of the land on which the project is located.

ALUA would also like to pay our respect to their Elders, both past and present.

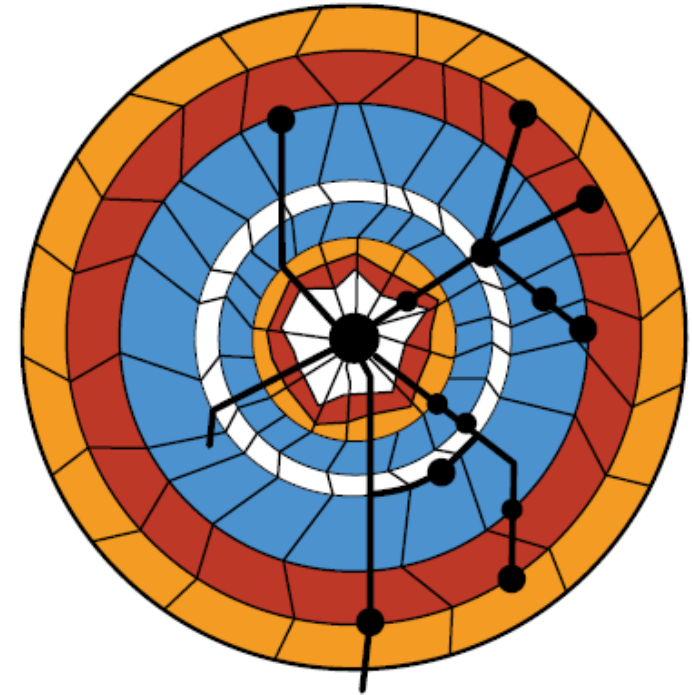

Agenda



- Project Overview
- Heavy Haulage Strategy
 - Planned route
 - Access to site
- Load Types and Numbers
- Traffic Management Plan
- Impact to PSP

Project Overview



- Victoria Park to Beckenham Level Crossing Removal Project
- 6 Level crossings to be removed
- 4 Elevated viaducts to be built
- 5 Elevated stations to be built
- Works to be delivered over 18 months shutdown of Armadale Line
- Shutdown commences late 2023
- Heavy Haulage from January 2024 to September 2024

Heavy Haulage Strategy

- Just in time delivery
- Roe Highway
- Avoid Welshpool Rd
- Access site via Bank St & Sevenoaks St
- Connect Bank St & Sevenoaks St

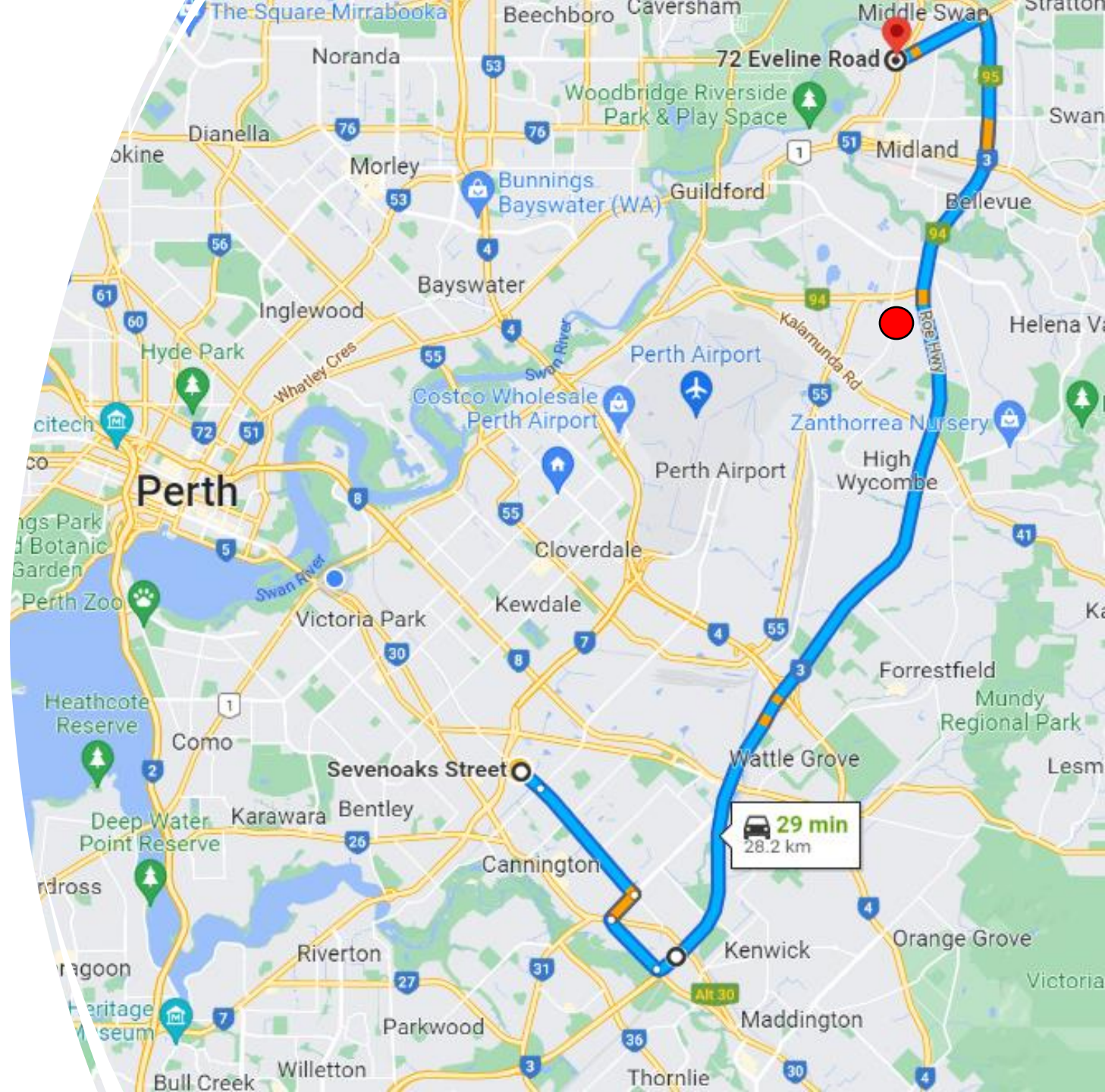

Temporary Storage

Current Option Locations

- 1: 54 Lakes Road, Hazelmere
- 2: Bickley Road, Kenwick
- 3: Tallangatta, Muchea

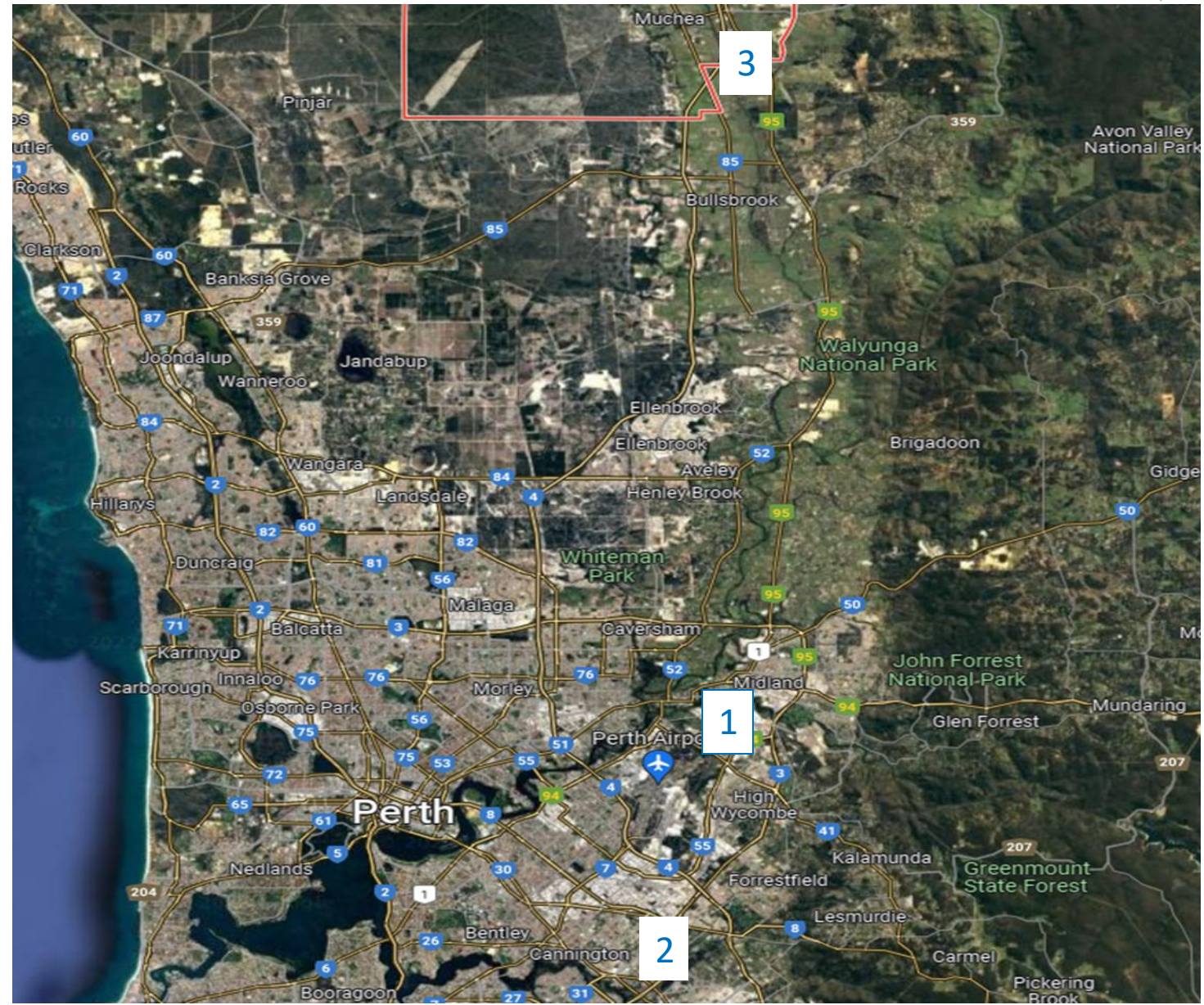

Heavy Haulage - Access to Site

Due to the restricted working area of the site, most of the large precast items will be delivered and installed in a 'just in time' arrangement.

1 Mint Street, 2 Oats Street, and 3 Welshpool Road



L Shape Precast Beam Transport Route via Bank Street and Sevenoaks Street from William Street to avoid congestion at Welshpool Road

4 Hamilton Street, 5 Wharf Street, and 6 William Street



L Shape Precast Beam Transport Route via Sevenoaks Street from William Street to avoid congestion at Welshpool Road. Modification to existing traffic island and light pole is required.

Viaduct 1 Access Routes

Heavy Haulage Exit from Construction site

- Access Gate located at Pier 7 and 8 for exiting before Carlisle station.

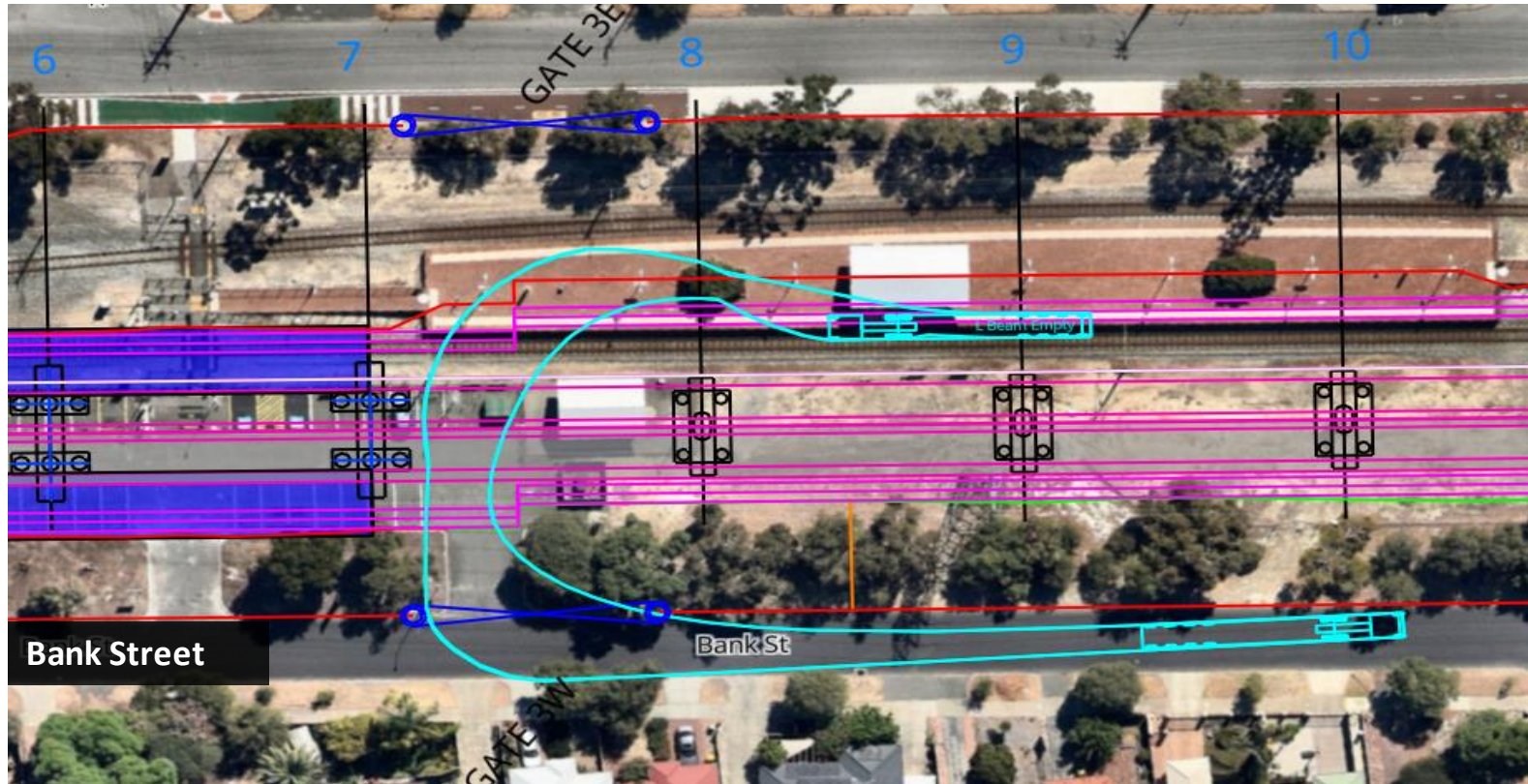

Summary of Heavy Elements

Number of Structural Elements Needs To Be Transported



Element Name	Quantity
Super T	40
Pier	169
Crosshead	154
L-Beams	532

Crosshead

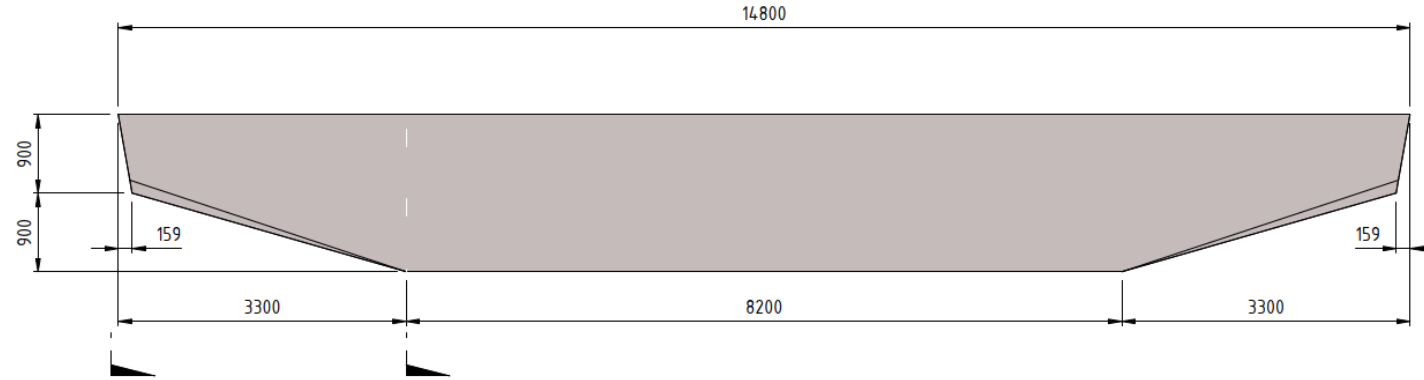
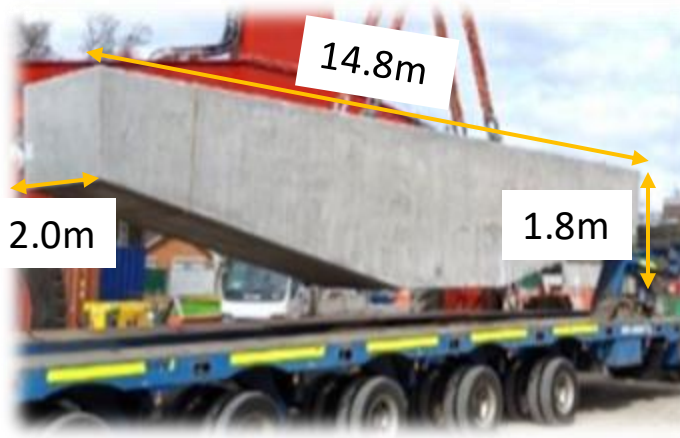

Max Weight	Max Dimensions	Quantity
120 tonnes	14.8m Wide 1.8m Deep 2.0m Long	154

➤ Delivering rate → Average: 5.8/week; Peak: 15/week over 7 month period

Pier

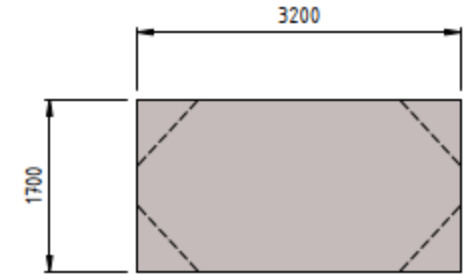
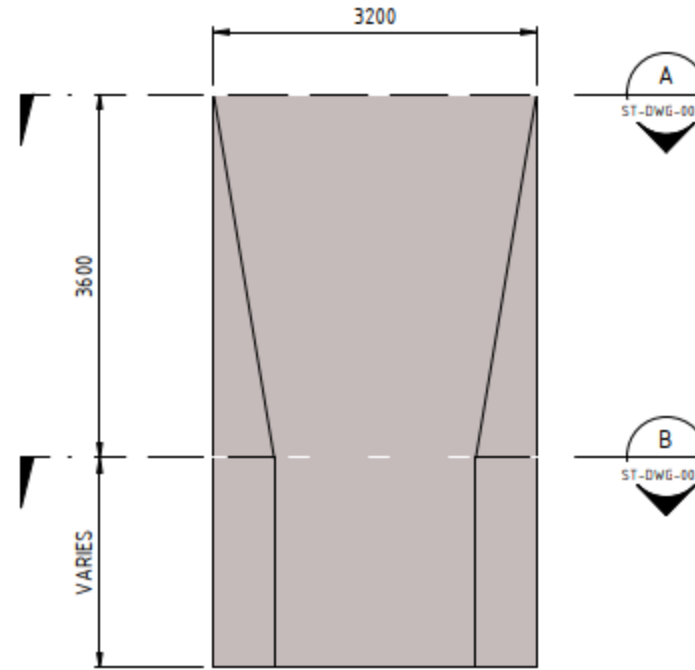

SECTION A
SCALE 1 : 50
ST-DWG-0035

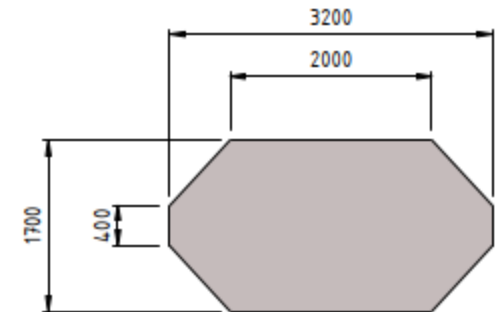

SECTION B
SCALE 1 : 50
ST-DWG-0035

Max Weight	Max Dimensions	Quantity
90 tonnes	3.2m Wide 7m Deep (max) 1.7m Long	169

➤ Delivering rate → Average: 5/week; Peak: 13/week over 7 month period

Super T & L-Beam

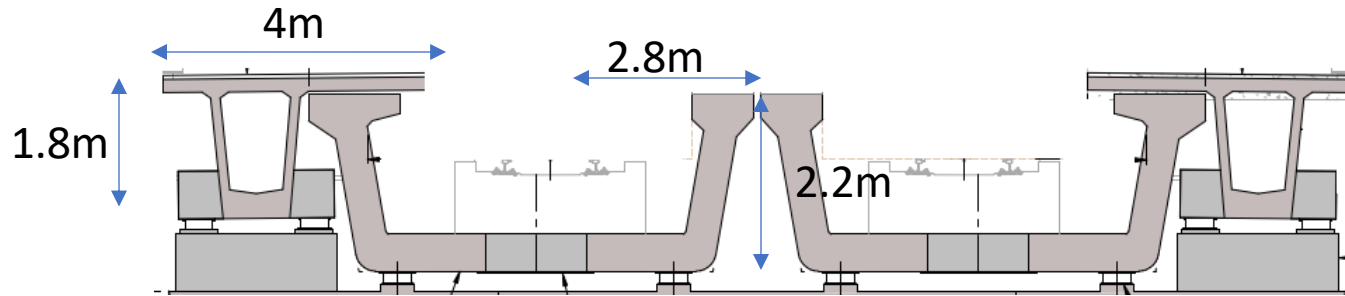

Element Name	Max Dimensions	Max Weight	Quantity
Super T	4m Wide 1.8m Deep 31m Long	130 tonnes	40
L-Beam	2.8 Wide 2.2m Deep 31m Long	130 tonnes	532

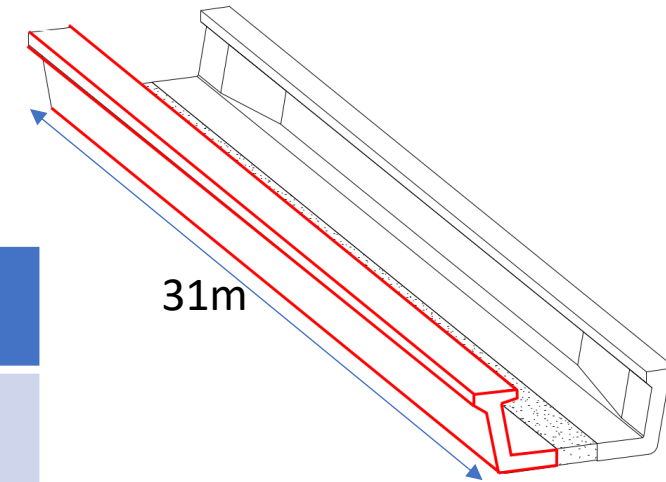

- Delivering rate (Super T) ➔ Average: 3/week; Peak: 6/week over 3 month period
- Delivering rate (L-Beams) ➔ Average: 14/week; Peak: 24/week over 7 month period

Super T & L-Beam

Typical Transport Haulage Layout

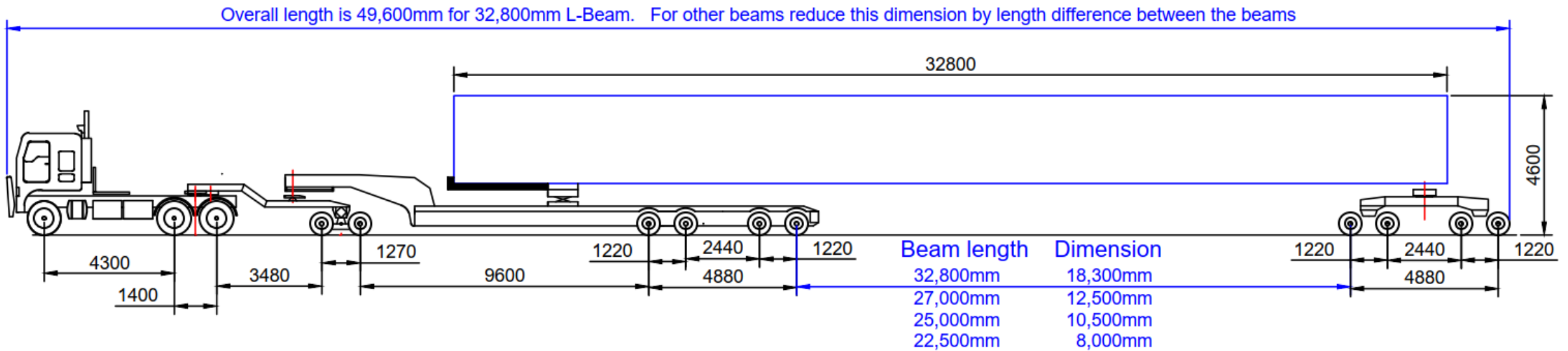

Heavy Haulage Schedule

Volume of Deliveries

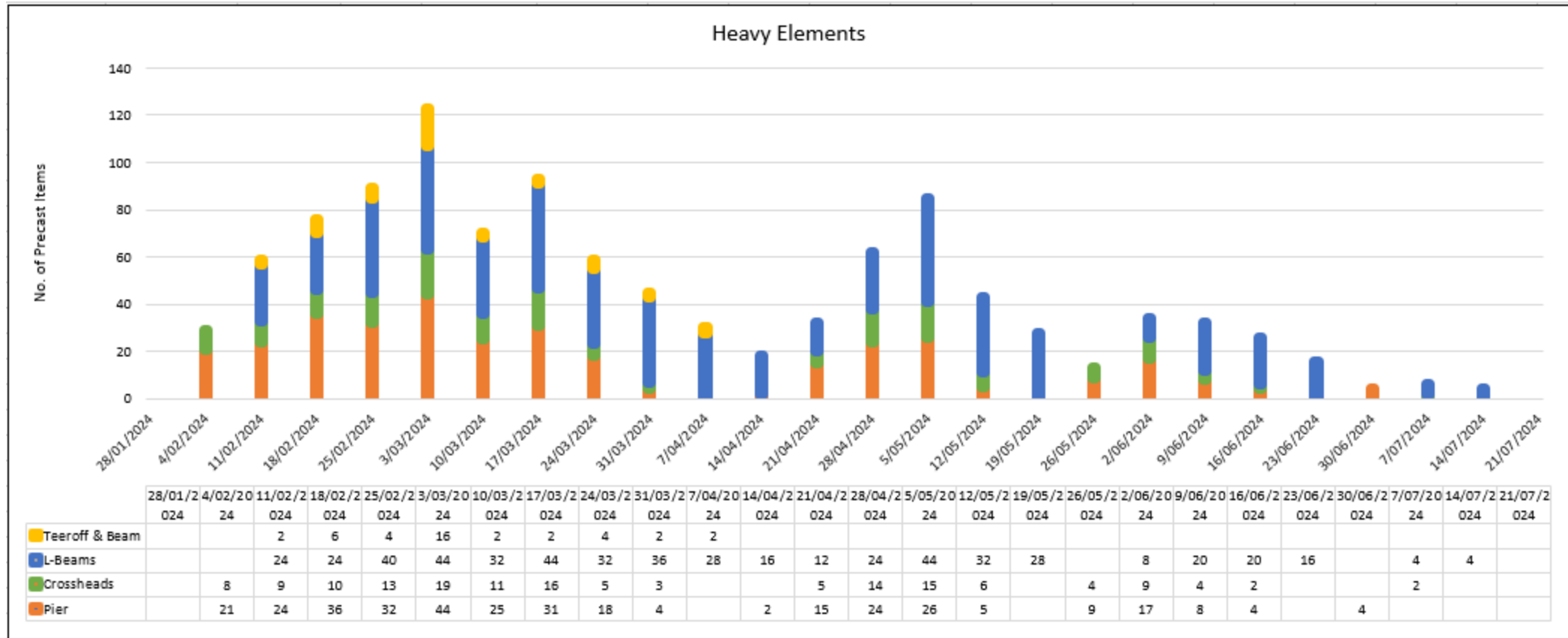

Impact to PSP

Construction works affecting existing Armadale Railway PSP

- Package 1: Only impact around Welshpool Road
- Construction vehicles will access/egress the site from the west side, avoiding crossing the PSP
- PSP detour will be required on the south side of Welshpool Rd, to enable the construction of the new PSP.



Impact to PSP

Construction works affecting existing Armadale Railway PSP

- Package 2: Affecting Mills St to Gerald St
- Access/egress to site will remain on the west side. Minimizing any interacting between site vehicles and PSP users.
- PSP detours will be required to enable construction works.
- Assessment is being done to move temporary PSP onto Railway Parade.



Traffic Management Plan

Documentation



Haulage TMP document will provide:

- Overview of route with detailed route mapping
- Assessment of all turns incl swept paths where required
- Height assessments where required
- Bridge assessments (based on MRWA HVS requirements/information, see below)
- Risk assessment for areas that require special treatment
- TGS for intersections/turns that require active control for OSOM loads
- Geometrical design for temporary pavements required to enable loads to move (i.e. Williams to Sevenoaks)